

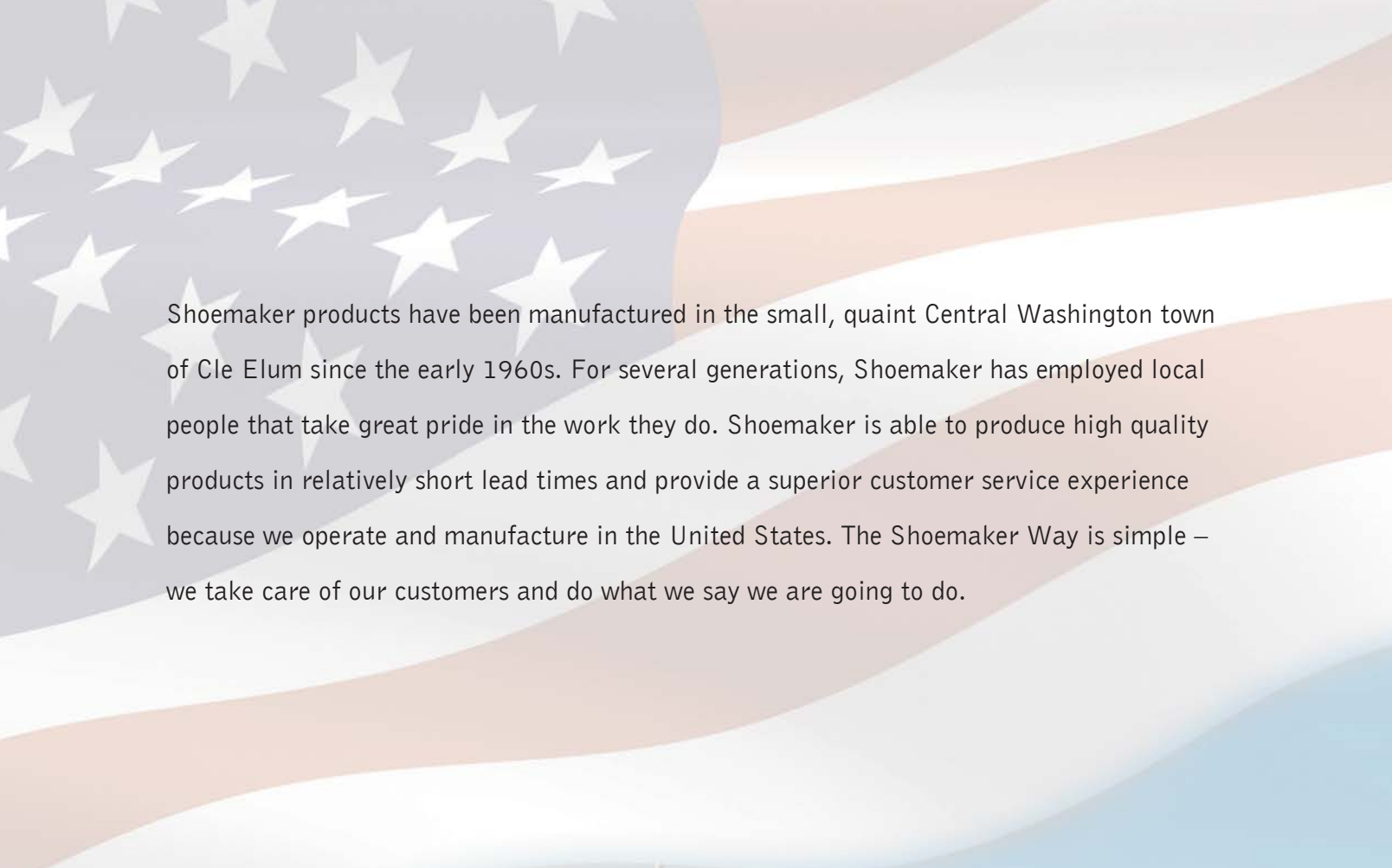

HOEMAKER
MANUFACTURING

Commercial Catalog











Shoemaker products have been manufactured in the small, quaint Central Washington town of Cle Elum since the early 1960s. For several generations, Shoemaker has employed local people that take great pride in the work they do. Shoemaker is able to produce high quality products in relatively short lead times and provide a superior customer service experience because we operate and manufacture in the United States. The Shoemaker Way is simple – we take care of our customers and do what we say we are going to do.





MODULAR CORE DIFFUSERS

		Page	Application
	MA Modular Core Diffuser	68	SM
	700 MA Modular Core Diffuser in T-Bar Panel	14	TBAR
	MA-T Full Size T-Bar Modular Core Diffuser	16	TBAR
	MA-SS Stainless Steel Fixed Pattern Ceiling Diffuser	232	SM TBAR

CURVED BLADE DIFFUSERS

	CB Adjustable Curved Blade Diffuser	64	SM
	700 CB Adjustable Curved Blade Diffuser in T-Bar Panel	17	TBAR
	CB-T Full Size T-Bar Adjustable Curved Blade Diffuser	19	TBAR

LOUVERED DIFFUSERS

	104 Stamped Curved Blade T-Bar Diffuser	20	TBAR
	100 Step Down Ceiling Diffuser	100	SM
	115T – Low Profile Step Down T-Bar Diffuser in Panel	25	TBAR
	DVD Directional Volume Diffuser	102	SM
	700 DVD Directional Volume Diffuser in T-Bar Panel	22	TBAR
	DVD-T Full Size T-Bar Directional Volume Diffuser	24	TBAR

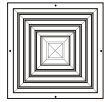

DVD-SS
Stainless Steel Directional Volume Diffuser

242

SM
TBAR



HVD
4 Cone T-Bar Diffuser

26

TBAR



HVD-SS
Stainless Steel 3 Cone T-Bar Diffuser

243

TBAR



HVL
3 Cone T-Bar Diffuser

28

TBAR

PLAQUE DIFFUSERS



HL
Architectural T-Bar plaque diffuser

30

TBAR
SM



HL-SS
Stainless Steel Architectural T-Bar Plaque Diffuser

244

TBAR

SPIRAL DIFFUSERS AND GRILLES



SD
Transition box spiral pipe diffuser

73

SPIRAL



RS
Radius Spiral Pipe Diffuser

76

SPIRAL



RS-SS
Stainless Steel flush mount spiral pipe diffuser

248

SPIRAL



USR
Universal Spiral Diffuser

70

SPIRAL

ADJUSTABLE BLADE DIFFUSERS



901 / 902
Adjustable Single Deflection Airfoil Blade Diffuser

80

SM



931 / 932
Adjustable Single Deflection Diffuser

80





SM



931-SS / 932-SS
Stainless Steel Adjustable Single Deflection Diffuser

233

SM

	903 / 904 Adjustable Double Deflection Airfoil Blade Diffuser	82	SM
	933 / 934 Adjustable Double Deflection Diffuser	82	SM
	933-SS / 934-SS Stainless Steel Adjustable Double Deflection Diffuser	234	SM
	950 Adjustable Single Deflection Diffuser for Ceiling or Sidewall	92	SM
	945 Adjustable 3 or 4-way Diffuser for Ceiling or Sidewall	94	SM

FIXED BLADE GRILLES

	905 / 906 Fixed 45° Airfoil Blade Grille	84	SM
	935 / 936 Fixed 45° Steel Blade Grille	84	SM
	935-SS / 936-SS Stainless Steel Fixed 45° Blade Grille	235	SM
	907 / 908 Fixed 0° Airfoil Blade Grille	84	SM
	937 / 938 Fixed 0° Steel Blade Grille	84	SM
	937-SS / 938-SS Stainless Steel Fixed 0° Blade Grille	235	SM
	915 / 916 Fixed 45° Aluminum Bar Blade Grille	88	SM
	915-SS / 916-SS Stainless Steel Fixed 45° Louvered Blade Grille	238	SM

SILL GRILLES AND DIFFUSERS

	1000 Extruded Aluminum Narrow Frame Fixed Blade Supply or Return	90	SILL
---	---	----	-------------

DOOR GRILLES



4000 / 4100
Aluminum Transfer Door Grille

79 **DOOR**

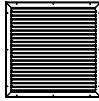

4100-SS
Stainless Steel Louvered Door Grille

237 **DOOR**

GYM GRADE REGISTERS AND GRILLES



1560
Heavy Duty Bar Blade Register

107 **FLOOR
SM**



1610
Heavy Duty Bar Blade Grille

110 **FLOOR
SM**

COMBINATION SUPPLY AND RETURN



SR
Combination Supply / Return

105 **SM**

ROUND DIFFUSERS



RDA
Adjustable Round Ceiling Diffuser

118 **SM
SPIRAL**



1201
Adjustable Aluminum Round Diffuser

119 **SM**



1202
Aluminum Round Spot Diffuser

120 **SM**



1203
Aluminum Turbo Nozzle Diffuser

121 **SM**

ARCHITECTURAL PATTERN GRILLES











1301-1308
Stamped Pattern Grilles

122 **SM**

PERFORATED DIFFUSER

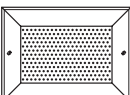
	110 Perforated Fiberglass Back T-Bar Diffuser with Deflector Grid	32	TBAR
	780 Hinged Perforated T-Bar with Adjustable Pattern Controllers	34	TBAR
	104P Perforated Stamped Curved Blade T-Bar Diffuser	36	TBAR
	500 Hinged Perforated Curved Blade Diffuser	96	SM
	825 Hinged Perforated Curved Blade T-Bar Diffuser	38	TBAR
	825CB-SS Hinged Stainless Steel Perforated T-Bar with Adjustable Curved Blade Diffuser	245	TBAR

PERFORATED RETURN

	PT Perforated T-Bar	40	TBAR
	105P Fixed Perforated T-Bar Return	41	TBAR
	600PT Perforated T-Bar Return with Extruded Aluminum Frame	42	TBAR
	600P Perforated Return with Extruded Aluminum Frame	97	SM
	600P-SS Stainless Steel Perforated Return Air Grille	239	SM TBAR
	830 Hinged Perforated T-Bar Return	43	TBAR
	830-SS Stainless Steel Perforated T-Bar Return	245	TBAR
	700-600P Perforated T-Bar Panel Return	44	TBAR

LATTICE RETURN

	AL Aluminum Lattice T-Bar Return	45	TBAR
	600T Aluminum Lattice T-Bar Return with Extruded Aluminum Frame	46	TBAR
	600 Aluminum Lattice Return with Extruded Aluminum Frame	98	SM
	600-SS Stainless Steel Lattice Return Air Grille	240	SM TBAR
	700-600 Aluminum Lattice Return in T-Bar Panel	48	TBAR

FIXED BLADE RETURN

	935T Fixed 45° Steel Blade Return Air Grille	49	TBAR
	915T Fixed 45° Bar Blade Return Air Grille	50	TBAR
	700-935 Fixed 45° Bar Return Air Grille in T-Bar Panel	51	TBAR

FIXED BLADE FILTER GRILLE

	935TFG Fixed 45° Blade T-Bar Filter Grille	55	TBAR
	935FG Fixed 45° Steel Blade Filter Grille	115	SM
	935FG-SS Stainless Steel Fixed 45° Filter Grille	235	SM TBAR
	905TFG Fixed 45° Airfoil Blade T-Bar Filter Grille	56	TBAR
	905FG Fixed 45° Airfoil Blade Filter Grille	114	SM



915TFG
Fixed 45° Bar Blade T-Bar Filter Grille

57

TBAR



915FG
Fixed 45° Bar Blade Filter Grille

117

SM

LOUVERED FILTER GRILLE



105FG
Stamped Face T-Bar Filter Grille

58

TBAR

PERFORATED FILTER GRILLE



105PFG
Perforated T-Bar Filter Grille

52

TBAR



600PTFG
Perforated T-Bar Filter Grille with Frame

53

TBAR



620PFG
Perforated Filter Grille

112

SM

ALUMINUM LATTICE FILTER GRILLE



600TFG
Aluminum Lattice T-Bar Filter Grille with Extruded Aluminum Frame

54

TBAR



620FG
Aluminum Lattice Filter Grille

112

SM

LINEAR DIFFUSERS AND GRILLES



Linear Bar Diffusers and Grilles

129



Linear-SS
Stainless Steel Linear Bar Grille

246



LSD
Linear Slot Diffusers

135



LSD-SS
Stainless Steel Linear Slot Diffuser

247



LAB/LJP
Air Bar Diffusers

140

AIR CONTROL DAMPERS



3000P
Parallel Blade Air Control Damper

144



3000 OBD
Opposed Blade Air Control Damper

145



3000P-R
Round Air Control Damper

146

FACE AND BY-PASS DAMPERS



3100
Face and By-Pass Dampers

147

PRESSURE RELIEF DAMPERS



3510
Pressure Relief Damper

148

BACKDRAFT DAMPERS



3550
Backdraft Damper

149

OUTSIDE AIR LOUVERS



4500
Stationary 4" Outside Air Louver

152



4525
Storm Resistant Stationary 4" Drainable Outside Air Louver

154



4550
Stationary 2" Outside Air Louver

156



4600
Adjustable 4" Outside Air Louver

158



4700
Stationary 4" Outside Air Louver Radius and Special Shapes

159



4800
Extruded Aluminum Brick Vent

160



4901
Round Aluminum Vent Louver

161

DAMPER LOUVER COMBINATIONS



Combination Dampers and Louvers

162

ACCESS DOORS



6000
Insulated Access Door

167



6700
Dry Wall Access Door

167



AD
Access Door

167



6600
Dual Panel Access Door

168

2" CURTAIN TYPE FIRE DAMPER



2502
Thinline 1 1/2 Hour Rated Fire Damper

172



2534
Thinline Out-of-Airstream 1 1/2 Hour Rated Fire Damper

173



2550
Round Thin-line Out-of-Airstream 1 1/2 Hour Rated Fire Damper

174



2561
Thinline 3 Hour Rated Fire Damper

175

4" CURTAIN TYPE FIRE DAMPER



2602
1 1/2 Hour Rated Fire Damper

177



2634
Out-of-Airstream 1 1/2 Hour Rated Fire Damper

178



2650
Round Out-of-Airstream 1 1/2 Hour Rated Fire Damper

179



2652
True Round 1 1/2 Hour Rated Fire Damper

180



2661
3 Hour Rated Fire Damper

181

CEILING RADIATION DAMPER



2701
3 Hour Rated Ceiling Radiation Butterfly Damper

184



2750
Round 3 Hour Rated Ceiling Radiation Butterfly Damper

185



2700CBA
1 Hour Rated Ceiling Radiation Damper with Register Box Assembly

186

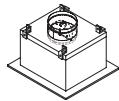

2750CBA
1 Hour Rated Round Ceiling Radiation Damper with Register Box Assembly

187



2720
3 Hour Rated Ceiling Radiation Curtain-type Damper

188

FIRE RATED T-BARS



FR Series
T-Bar Diffusers and Returns with UL Fire Resistance Classification

197

FIRE RATED ACCESS DOORS

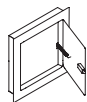

6800
Fire Rated Wall Access Door

190



6900
Fire Rated Ceiling Access Door

191

DYNAMIC FIRE DAMPERS

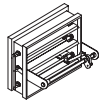

2800
1 1/2 Hour Dynamic Fire Damper

195

FIRE-SMOKE DAMPERS

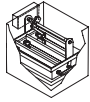

CFSD-222-2
1 Hour Rated Corridor Fire and Smoke Damper

193



FSD-111-2
1 1/2 Hour Rated Fire and Smoke Damper

192

SECURITY SUPPLY AND RETURN



1401
Bar Type Security Grille

202



1402
Face Plate / Screen / Backer Plate Security Grille

203



1404
Wire Screen Face Security Return

204



1405
Square Hole Lattice Face Security Grille

205



1406
Perforated Face Security Grille

206



1407
Rectangular Hole Lattice Face Security Grille

207



1408
Lattice Face Security Diffuser

208

RISK RESISTANT SECURITY DIFFUSERS AND GRILLES

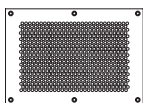

1409
Risk Resistant Security Grille Perforated Face

209

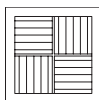

1410
Risk Resistant Louvered Face Security Diffuser and Sleeve

210

OVERVIEW

Shoemaker T-Bar (lay-in) products are designed for ceiling grid systems. Our product designs focus on quality and practicality. Standard features incorporated into our T-Bar product line include:

- Fits into a 2×2 area in ceiling grid system
- Seismic support holes
- 2" ADC compliant round collar with bead for ease of installation
- Rust resistant pre-coat with durable Soft White powder coat paint finish

Product Key

The product key located on the bottom of each page uses symbols to note options, features and services that are found repeatedly throughout this section of the catalog:

 **SOFT WHITE**

Rust resistant pre-coat with durable powder coat paint finish in Soft White.



DESIGNER COLOR

Rust resistant pre-coat with durable powder coat paint finish available in custom colors. See appendix or website for list of available colors. Additional charges apply.



ALUMINUM PAINT

Closely replicates a cleaned aluminum finish with the added benefits of our powder coat painting process. Additional charges apply.



SATIN ANODIZED

Constructed with satin anodized aluminum extrusions best described as a polished aluminum look. Factory cleaned prior to shipping. Additional charges apply.



FIELD ADJUSTABLE

Product has standard features and/or options to allow for adjustment in the field.



HIGH CAPACITY

Product is designed to deliver high volumes of air.



MRI COMPATIBLE

Constructed with MRI compatible materials (standard product or available option).



EXPEDITED SERVICES PROGRAM

Available with Expedited Service Program, products manufactured faster than standard leadtimes. Additional charges apply. See website for program details.

MODULAR CORE T-BAR DIFFUSERS



700MA Series Modular Core Diffuser in T-Bar Panel

Standard Features:

- Adjustable modular cores with fixed curved blade
- Maintains horizontal airflow pattern
- 2" ADC compliant round collar with bead for ease of installation
- Standard collar diameter is the same as the diffuser size
- Diffuser available in sizes 6×6 through 20×20
- Rust resistant pre-coat with durable powder finish
- Soft White

Options:

- Modular cores with individually adjustable curved blades
MODEL: 700MCB
- Recessed screwdriver operated Opposed Blade Damper
MODEL: 700MA-0 / 700MCB-0
- Square Collar
- Non-standard size collar (available in 6" through 20")
- TVB – Thermal Vapor Blanket
- NGD – Narrow ceiling grid dimples for 9/16" T-Rails, changes O.D. to 23 29/32"

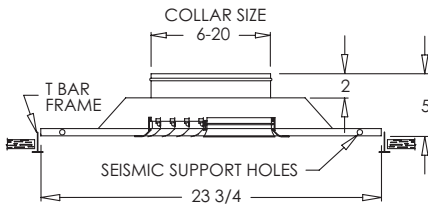

700MA

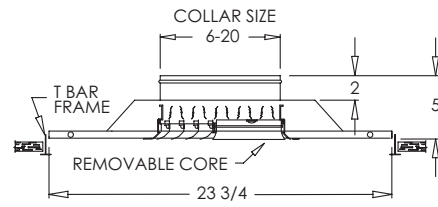

700MA-0

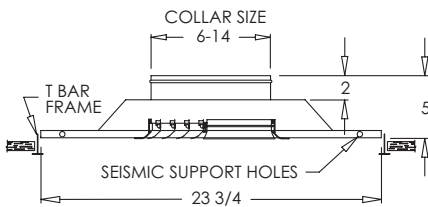

700MCB

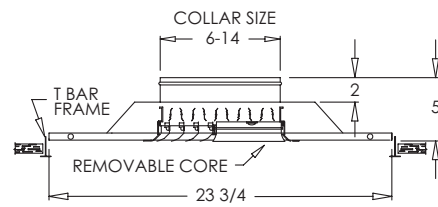



700MCB-0

Performance Data: 700MA/700MCB Series

Neck Size	Core Eff. Area (ft²)	Neck Velocity (FPM) Total Pressure	400	500	600	700	800	1000
			0.038	0.108	0.155	0.220	0.285	0.438
6×6-6	0.124	CFM	49	62	74	87	99	124
		NC	<20	<20	<20	20	20	20
		Throw (ft.)	2 3 5	2 3 7	3 4 8	3 5 9	4 6 12	5 7 13
8×8-8	0.245	CFM	98	122	147	171	196	245
		NC	<20	<20	<20	20	20	20
		Throw (ft.)	3 4 8	4 5 9	4 6 12	6 8 13	7 9 15	8 10 17
10×10-10	0.406	CFM	163	203	244	284	325	406
		NC	<20	<20	20	25	25	25-30
		Throw (ft.)	4 6 12	6 8 14	7 9 16	8 11 17	9 12 19	10 14 22
12×12-12	0.608	CFM	243	304	365	426	487	608
		NC	<20	20	25	25	25-30	30
		Throw (ft.)	6 8 16	8 11 17	10 13 19	12 15 21	12 16 24	14 18 26
14×14-14	0.851	CFM	341	426	511	596	681	851
		NC	<20	20	25	25-30	25-30	30
		Throw (ft.)	8 10 18	11 14 20	14 17 23	15 18 26	16 19 29	17 21 30
16×16-16	1.135	CFM	454	567	681	794	908	1135
		NC	<20	20	25	25-30	30	30
		Throw (ft.)	10 13 21	13 16 24	15 18 28	16 19 29	17 21 32	19 23 35
18×18-18	1.459	CFM	584	729	875	1021	1167	1459
		NC	20	20	25	25-30	30	30
		Throw (ft.)	11 15 25	15 18 28	17 20 32	18 22 34	20 24 36	21 25 39
20×20-20	1.823	CFM	729	912	1094	1276	1459	1823
		NC	20	20	25	25-30	30	30
		Throw (ft.)	13 18 28	16 20 30	19 23 35	21 25 39	22 26 41	23 28 44

Performance Notes:

- 1 For square neck multiply CFM × 1.21
- 2 Additional performance data for sizes not listed is available at www.shoemakermfg.com
- 3 Throw values are measured in feet for terminal velocities of 150/100/50 FPM
- 4 Throw data is based on supply air and room air both at isothermal conditions
- 5 Effective core areas listed in chart are defined as the measurement of space between the blades actually being utilized by the air
- 6 Data obtained from tests conducted in accordance with ANSI/ASHRAE standard 70-2006

Throw factors for core configuration: (Throw × Throw Factor)		1. 1.00 throw factor		2. 1.40 throw factor		3. 2.00 throw factor
---	---	----------------------	---	----------------------	---	----------------------



MODULAR CORE T-BAR DIFFUSERS



MA-T Series Modular Core Diffuser T-Bar

Standard Features:

- Adjustable modular cores with fixed curved blade
- Maintains horizontal airflow pattern
- Extruded aluminum frame with signature line marks
- Square collar designed for 22" × 22" duct only
- Rust resistant pre-coat with durable powder finish
- Soft White

Options:

- Recessed screwdriver operated Opposed Blade Damper
MODEL: MA-T-O
- 2" ADC compliant round collar with bead for ease of installation

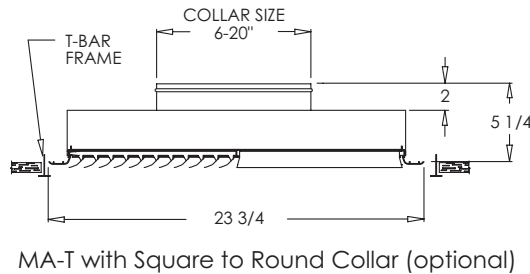
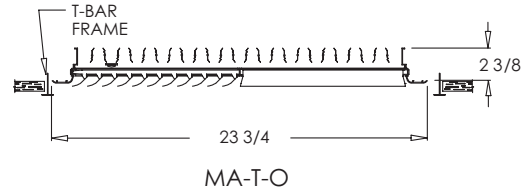
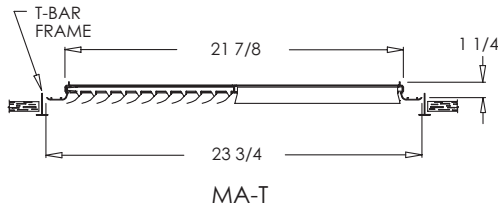

Performance Data: MA-T Series

Neck Size	Core Eff. Area (ft ²)	Neck Velocity (FPM)	Total Pressure																							
			300	400	500	600	700	800	1000	1200																
22×22	2.857	CFM	857	1143	1429	1714	2000	2286	2857	3428																
		NC	<20	<20	20	25	25-30	30	30-35	35																
		Throw (ft.)	12	16	24	14	18	30	18	23	36	19	25	40	21	26	43	22	28	45	24	30	49	23	30	48

Performance Notes:

- 1 Throw values are measured in feet for terminal velocities of 150/100/50 FPM
- 2 Throw data is based on supply air and room air both at isothermal conditions

- 3 Effective core areas listed in chart are defined as the measurement of space between the blades actually being utilized by the air

- 4 Data obtained from tests conducted in accordance with ANSI/ASHRAE standard 70-2006

Throw factors for core configuration: (Throw × Throw Factor)	1.	2.	3.
	1.00 throw factor	1.40 throw factor	2.00 throw factor

CURVED BLADE T-BAR DIFFUSERS



700CB Series Adjustable Curved Blade Diffuser in T-Bar Panel

Standard Features:

- Adjustable curved blade diffuser
- Five air patterns available
- Nylon bushings on adj. blades prevent metal on metal rattle
- Diffuser available in sizes 6×6 through 20×20
- Standard collar diameter is the same as the diffuser size
- 2" ADC compliant round collar with bead for ease of installation
- Rust resistant pre-coat with durable powder finish
- Soft White

Options:

- Recessed screwdriver operated Opposed Blade Damper
MODEL: 700CB-O
- Square Collar
- Non-standard size collar (available in 6" through 20")
- TVB – Thermal Vapor Blanket
- NGD – Narrow ceiling grid dimples for 9/16" T-Rails, changes O.D. to 23 29/32"

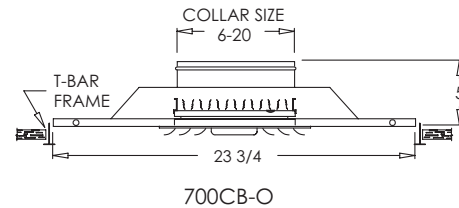
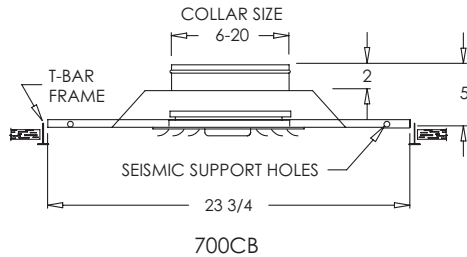

Air Patterns:

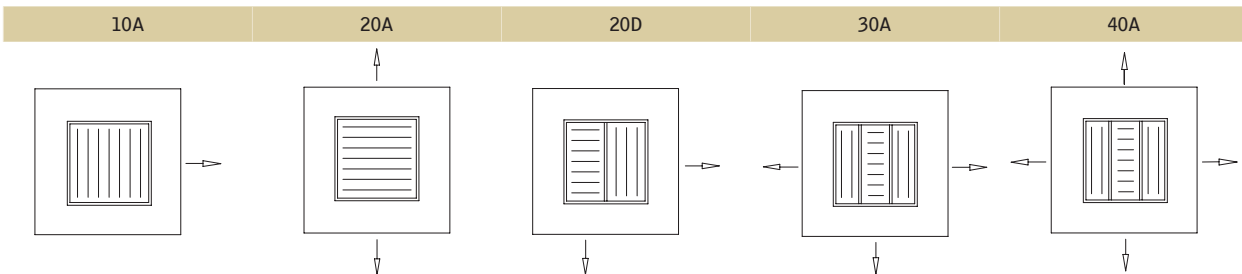

Performance Data: 700CB Series (40A Air Pattern)

Neck Size	Core Eff. Area (ft ²)	Neck Velocity (FPM)		400		500		600		700		800		1000						
		Total Pressure	CFM	NC	Throw (ft.)	CFM	NC	Throw (ft.)	CFM	NC	Throw (ft.)	CFM	NC	Throw (ft.)	CFM	NC	Throw (ft.)			
6×6-6	0.123	Total Pressure	0.038	0.108	0.155	0.22	0.285	0.438												
		CFM	49	61	74	86	98	123												
		NC	<20	<20	<20	<20	20	20												
8×8-8	0.239	Throw (ft.)	2	2.5	3.5	2	3	4	3	3.5	4.5	3	4	6	4	5	7	5	6	10
		CFM	95	119	143	167	191	239												
		NC	<20	<20	<20	<20	20	25												
10×10-10	0.392	Throw (ft.)	2	3	4	3	3.5	4.5	4	5	7	5	6	8	5	6.5	10	6	8	13
		CFM	157	196	235	275	314	392												
		NC	<20	<20	20	20-25	25	25-30												
12×12-12	0.584	Throw (ft.)	3	3.5	4.5	3	4	6	5	5.5	8.5	6	6.5	9.5	6	7	11	7	9.5	14.5
		CFM	234	292	350	409	467	584												
		NC	<20	<20	20	20-25	25	25-30												
14×14-14	0.814	Throw (ft.)	3	4	6	4	5	7	6	7	10	7	8	10.5	7	9	13	9	12	18
		CFM	325	407	488	569	651	814												
		NC	<20	<20	20	25	25-30	30												
16×16-16	1.081	Throw (ft.)	4	5	7	5	6	8	7	8	11	8	9	13	8	10	15	11	14	20
		CFM	432	540	649	757	865	1081												
		NC	<20	<20	20	25	25-30	30												
18×18-18	1.386	Throw (ft.)	5	7	9	6	7.0	10	8	9.5	12.5	9	11	15	10	12	18	13	15	23
		CFM	555	693	832	970	1109	1386												
		NC	<20	<20	20	25	25-30	30												
20×20-20	1.730	Throw (ft.)	6	7	10	8	10	12	9	11	15	11	13	17	12	13.5	21	14	18	26
		CFM	692	865	1038	1211	1384	1730												
		NC	<20	<20	20	25	25-30	30												
		Throw (ft.)	9	10	12	10	11.5	14.5	10	12	16	12	14.5	20	13	15	23	15	19	29

Performance Notes:

- 1 For square neck multiply CFM × 1.21
- 2 Additional performance data for sizes not listed is available at www.shoemakermfg.com
- 3 Throw values are measured in feet for terminal velocities of 150/100/50 FPM

- 4 Throw data is based on supply air and room air both at isothermal conditions
- 5 Effective core areas listed in chart are defined as the measurement of space between the blades actually being utilized by the air

- 6 Data obtained from tests conducted in accordance with ANSI/ASHRAE standard 70-2006

CURVED BLADE T-BAR DIFFUSERS



CB-T Series Adjustable Curved Blade T-Bar Diffuser

Standard Features:

- Adjustable curved blade diffuser
- Five air patterns available
- Extruded aluminum frame with signature line marks
- Nylon bushings on adj. blades prevent metal on metal rattle
- Square collar designed for 22" x 22" duct
- Rust resistant pre-coat with durable powder finish
- Soft White

Options:

- Recessed screwdriver operated Opposed Blade Damper
- **MODEL: CB-T-0**
- 2" ADC compliant round collar with bead for ease of installation
- 1x1 T-Bar (10" x 10" duct)
- 1x2 T-Bar (10" x 22" duct)
- 2x4 T-Bar (22" x 46" duct)

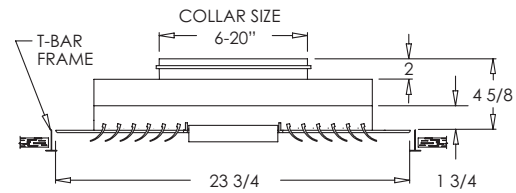
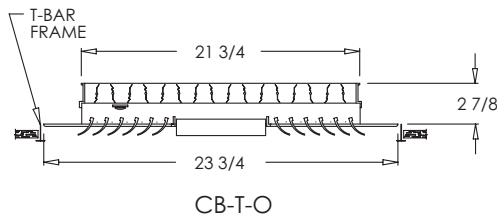
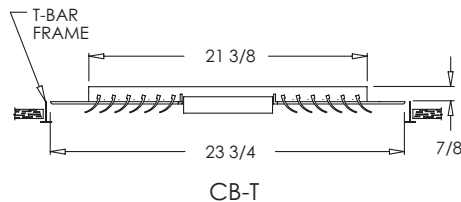

Air Patterns:

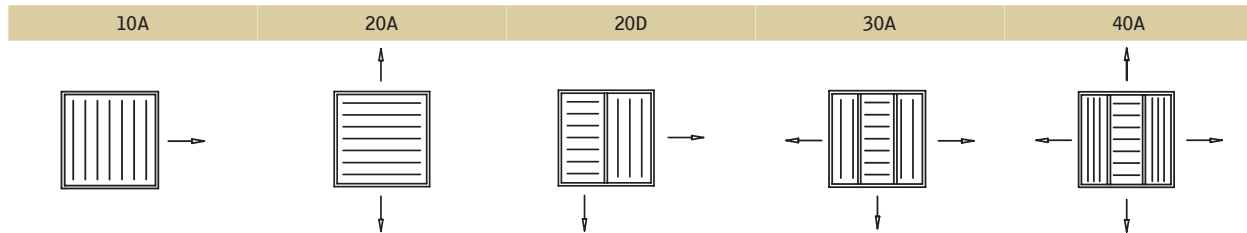

Performance Data: CB-T Series (40A Air Pattern)

Neck Size	Core Eff. Area (ft ²)	Neck Velocity (FPM)	Total Pressure																					
			300	400	500	600	700	800	1000	1200														
22x22	2.706	CFM	812	1082	1353	1624	1894	2165	2706	3247														
		NC	<20	<20	20	25	25-30	30	30-35	35														
		Throw (ft.)	8	9	11	9	10	12	11	13	17	13	15	20	14	16	22	15	18	26	20	24	36	22

Performance Notes:

1 Throw values are measured in feet for terminal velocities of 150/100/50 FPM
 2 Throw data is based on supply air and room air both at isothermal conditions

3 Effective core areas listed in chart are defined as the measurement of space between the blades actually being utilized by the air

4 Data obtained from tests conducted in accordance with ANSI/ASHRAE standard 70-2006



Field Adjustable



High Capacity



MRI Compatible



Expedited Service

LOUVERED BLADE T-BAR DIFFUSERS



104 Series Stamped Curved Blade T-Bar Diffuser

Standard Features:

- Stamped curved blade T-Bar diffuser with four way air pattern
- Five air patterns available
- 2" ADC compliant round collar with bead for ease of installation
- Standard collar diameter is 2" smaller than face (ex. 12×12 face has a 10" collar)
- Rust resistant pre-coat with durable powder finish
- Soft White

Options:

- Lever operated Multi-Shutter Damper
MODEL: 104-D
- Lever operated Opposed Blade Damper
MODEL: 104-O
- Perforated face
MODEL: 104P
- Square collar
- TVB – Thermal Vapor Blanket
- NGD – Narrow ceiling grid dimples for 9/16" T-Rails, changes O.D. to 23 29/32"

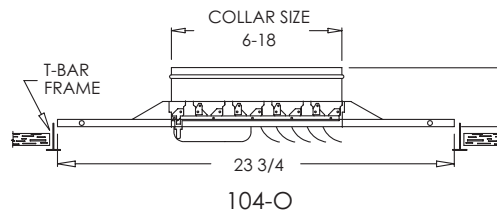
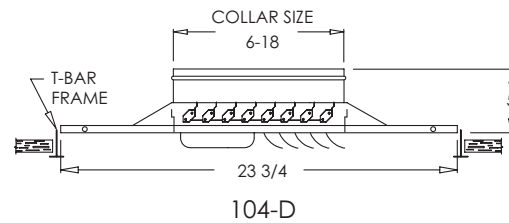
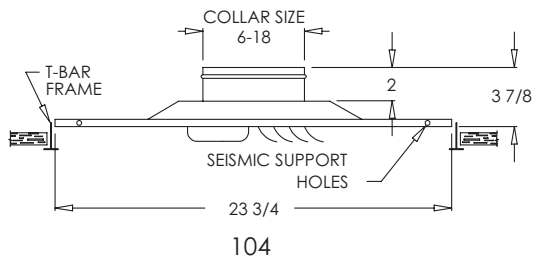

Air Patterns:

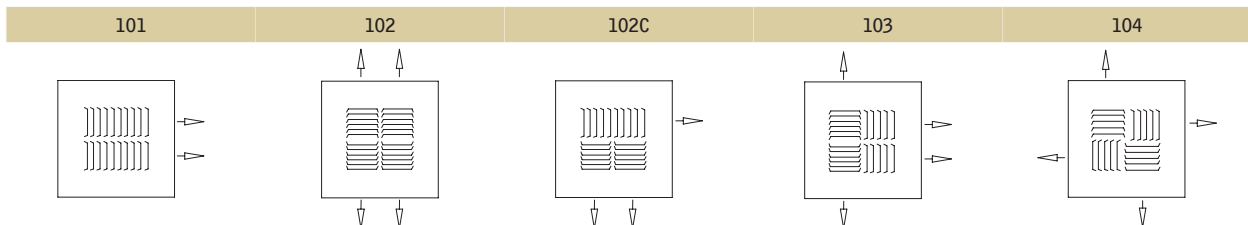

Performance Data: 104 Series (104 Air Pattern)

Neck Size	Core Eff. Area (ft ²)	Neck Velocity (FPM) Velocity Pressure	300	400	500	600	700	800	900	1000
			0.007	0.011	0.017	0.024	0.032	0.044	0.056	0.067
8×8-6	0.174	CFM	52	70	87	104	122	139	157	174
		NC	<20	20-25	25-30	30	35	35-40	40	45
		Throw (ft.)	2 3 4	3 4 5.5	4 5 7	5 6 8	6 7 10	7 8.5 11	8 9 14	9 11 15
10×10-8	0.323	CFM	97	129	161	194	226	258	291	323
		NC	<20	20-25	25-30	30	35	35-40	40	45
		Throw (ft.)	3 3.5 4.5	4 4.5 6	5 5.5 7.5	6 7 9	7 7.5 10.5	8 9 12	9 10 15	10 12 18
12×12-10	0.519	CFM	156	208	259	311	363	415	467	519
		NC	20	25-30	30	30	<40	40-45	45	45
		Throw (ft.)	4 4.5 5.5	5 5.5 7	6 7 9	7 8 10.5	8 9.5 12.5	9 10 14	10 12 18	11 13 19
14×14-12	0.762	CFM	229	305	381	457	533	609	686	762
		NC	20	25-30	30	30-35	<40	40-45	45	50
		Throw (ft.)	5 5.5 6.5	6 7 9	7 8 11	8 10 14	10 12 16	11 14 18	12 15 22	14 17 25
16×16-14	1.052	CFM	316	421	526	631	736	841	947	1052
		NC	25	25-30	30	35	35-40	45	<50	50
		Throw (ft.)	5 6 8	7 7.5 9.5	8 9 12	10 11.5 16	11 13.5 19	13 16 22	14 17 25	16 19 29
18×18-16	1.357	CFM	407	543	678	814	950	1085	1221	1357
		NC	25-30	30	30-35	35-40	40	45	50	>50
		Throw (ft.)	6 7 9	8 9 11	9 10 14	11 13 17	13 15 21	15 17 23	16 18 26	17 20 30

Performance Notes:

- 1 For square neck multiply CFM × 1.21
- 2 Additional performance data for sizes not listed is available at www.shoemakermfg.com
- 3 Throw values are measured in feet for terminal velocities of 150/100/50 FPM

- 4 Throw data is based on supply air and room air both at isothermal conditions
- 5 Effective core areas listed in chart are defined as the measurement of space between the blades actually being utilized by the air

- 6 Data obtained from tests conducted in accordance with ANSI/ASHRAE standard 70-2006



Field Adjustable



High Capacity



MRI Compatible



Expedited Service

LOUVERED T-BAR DIFFUSERS



700DVD Series Directional Volume Diffuser in T-Bar Panel

Standard Features:

- Directional volume diffuser with 4-way removable core
- Designed to handle high volumes of air with horizontal flow
- Five air patterns available
- 2" ADC compliant round collar with bead for ease of installation
- Standard collar diameter is the same as the diffuser size
- Diffuser available in sizes 6×6 through 18×18
- Rust resistant pre-coat with durable powder finish
- Soft White

Options:

- Recessed screwdriver operated Opposed Blade Damper
MODEL: 700DVD-O
- Adjustable baffles to control air flow through diffuser
MODEL: 700DVD-ADJ
- Square Collar
- Non-standard size collar (available in 6" through 20")
- TVB – Thermal Vapor Blanket
- NGD – Narrow ceiling grid dimples for 9/16" T-Rails, changes O.D. to 23 29/32"

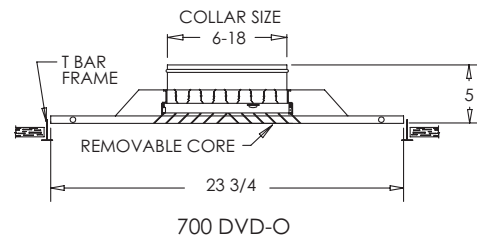
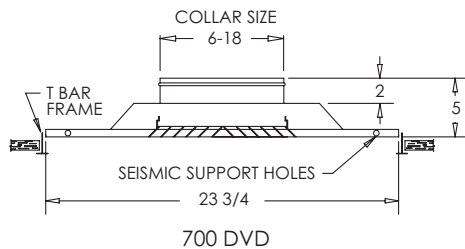

Air Patterns:

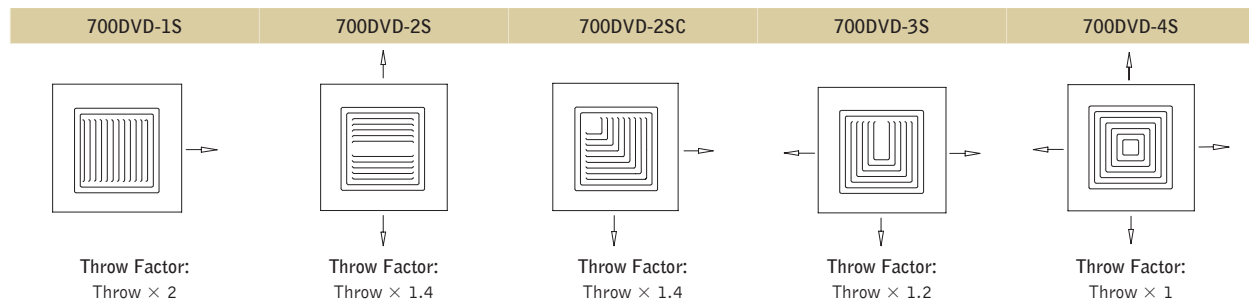

(Use with performance data on following page)

Performance Data: 700DVD Series (4S Air Pattern)

Neck Size	Core Eff. Area (ft ²)	Neck Velocity (FPM)	400		500			600			700			800			1000			
			Total Pressure			CFM			NC			Throw (ft.)			CFM			NC		
6×6-6	0.122		0.038			61			73			85			98			122		
			<20			<20			20			20			25			25		
			4	6	8	5	7	9	6	8	10	7	9	11	8	10	14	8	11	15
			CFM			115			138			161			184			230		
8×8-8	0.230		<20			<20			20			20			25			25		
			5	7	9	6	8	10	7	9	11	8	10	13	9	11.5	16	10	13	17
			CFM			186			223			260			297			371		
			NC			<20			20			20-25			25			25-30		
10×10-10	0.371		6	8	10	7	9	13	8	10	14	10	12	16	11	13	17	12	15	19
			CFM			273			328			383			437			547		
			NC			<20			20			20-25			25			25-30		
			Throw (ft.)			10			12			14			16			18		
12×12-12	0.547		7	9	11	8	10	12	9	11	15	11	13	17	12	14	18	13	16	21
			CFM			378			453			529			605			756		
			NC			20			25			25-30			30			30-35		
			Throw (ft.)			11.5			14.5			17			20			23		
14×14-14	0.756		8	10	12	10	11.5	14.5	10	12.5	17	12	14	18	13	15	20	14	17	23
			CFM			499			599			699			799			999		
			NC			20			25			25-30			30			30-35		
			Throw (ft.)			13.5			17			20			23			27		
16×16-16	0.999		9	11.5	14.5	11	13.5	17	12	16	20	13	17	23	14	18	24	15	19	27
			CFM			638			765			893			1020			1275		
			NC			20			25			25-30			30			30-35		
			Throw (ft.)			15			19			20			24			27		
18×18-18	1.275		634			793			952			1110			1269			1586		
			NC			20			25-30			30-35			35-40			40-45		
			Throw (ft.)			14			17			20			24			27		
			Total CFM			21			25			28			30			32		
20×20-20	1.586		<20			20			25-30			30-35			35-40			40-45		
			NC			20			25-30			30-35			35-40			40-45		
			Throw (ft.)			14			17			20			24			27		

Performance Notes:

- 1 For square neck multiply CFM × 1.21
- 2 Additional performance data for sizes not listed is available at www.shoemakermfg.com
- 3 Throw values are measured in feet for terminal velocities of 150/100/50 FPM

- 4 Throw data is based on supply air and room air both at isothermal conditions
- 5 Effective core areas listed in chart are defined as the measurement of space between the blades actually being utilized by the air

- 6 Data obtained from tests conducted in accordance with ANSI/ASHRAE standard 70-2006



Field Adjustable



High Capacity



MRI Compatible



Expedited Service

LOUVERED T-BAR DIFFUSERS



DVD-T Series Directional Volume Diffuser T-Bar

Standard Features:

- Directional volume diffuser with 4-way removeable core
- Designed to handle high volumes of air with horizontal flow
- Five air patterns available
- Square collar designed for 20" × 20" duct
- Rust resistant pre-coat with durable powder finish
- Soft White

Options:

- Recessed screwdriver operated Opposed Blade Damper
MODEL: DVDT-O
- 2" ADC compliant round collar with bead for ease of installation

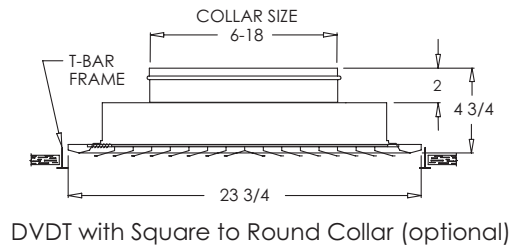
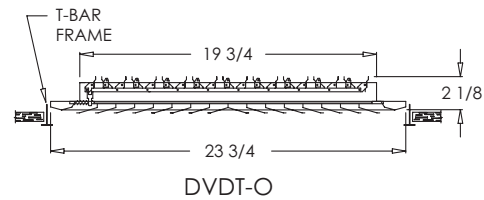
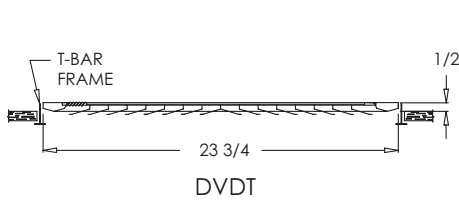

Air Patterns:

DVD-T-1S	DVD-T-2S	DVD-T-2SC	DVD-T-3S	DVD-T-4S
Throw Factor: Throw × 2	Throw Factor: Throw × 1.4	Throw Factor: Throw × 1.4	Throw Factor: Throw × 1.2	Throw Factor: Throw × 1

Performance Data: DVD-T Series

Neck Size	Core Eff. Area (ft ²)	Neck Velocity (FPM)	400		500		600		700		800		1000	
			Total Pressure	CFM	Total Pressure	CFM	Total Pressure	CFM	Total Pressure	CFM	Total Pressure	CFM		
20 × 20	2.475		0.038	990	0.108	1237	0.155	1485	0.220	1732	0.285	1980	0.438	2475
		NC	<20	20	25	25-30	30	30-35						
		Throw (ft.)	16 18 21	17 19 23	19 21 27	20 22 30	21 24 32	22 25 34						

Performance Notes:

1 Throw values are measured in feet for terminal velocities of 150/100/50 FPM
 2 Throw data is based on supply air and room air both at isothermal conditions

3 Effective core areas listed in chart are defined as the measurement of space between the blades actually being utilized by the air

4 Data obtained from tests conducted in accordance with ANSI/ASHRAE standard 70-2006

LOUVERED T-BAR DIFFUSERS



115T Series Flush Step Down T-Bar Diffuser

Standard Features:

- 4-way flush step down steel diffuser
- Low profile design for tight mechanical areas
- Delivers supply air in a 360° air pattern
- 2" ADC compliant round collar with bead for ease of installation
- Available in 6"-12" collar sizes
- Rust resistant pre-coat with durable powder finish
- Soft White

Options:

- Center hole in face for damper adjustment

MODEL: 116T

- BD – Field installable Bowtie Damper
- TVB – Thermal Vapor Blanket
- NGD – Narrow ceiling grid dimples for 9/16" T-Rails, changes O.D. to 23 29/32"

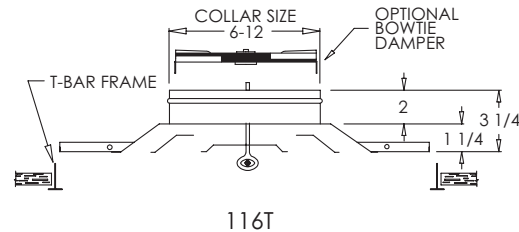
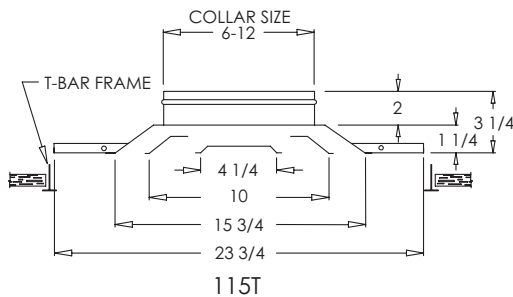

Performance Data: 115T/116T Series

Neck Size	Core Eff. Area (ft²)	Neck Velocity (FPM) Velocity Pressure	300	400	500	600	700	800	900	1000	1200
			0.007	0.011	0.017	0.024	0.032	0.044	0.056	0.067	0.095
6"	0.175	CFM	53	70	88	105	123	140	158	175	210
		NC	<20	<20	<20	20	20	25	25	25	30
		Throw (ft.)	2 2 3 2 2 4	2 2.5 4.5 3 3.5 5 4 5 8	4 5 7 5 6 9 6 7 10 7 9 11						
8"	0.311	CFM	93	124	156	187	218	249	280	311	373
		NC	<20	<20	<20	20	20	25	25	30	30
		Throw (ft.)	2 3 5 3 4 6 3 4 7 4 5 9 5 6 10 5 7 11 6 8 12 8 9 13 9 10 14								
10"	0.486	CFM	146	194	243	292	340	389	438	486	583
		NC	<20	<20	<20	20	20-25	25	25-30	30	30
		Throw (ft.)	3 3 6 3 4 8 4 5 9 5 6 10 6 8 12 6 8 13 7 9 14 9 10 16 10 11 17								
12"	0.700	CFM	210	280	350	420	490	560	630	700	840
		NC	<20	<20	20	20	20-25	25	30	30-35	35
		Throw (ft.)	3 4 8 4 5 9 5 7 11 6 8 14 7 9 15 8 10 16 9 11 17 10 12 18 11 13 19								

Performance Notes:

- 1 For square neck multiply CFM × 1.21
- 2 Throw values are measured in feet for terminal velocities of 150/100/50 FPM
- 3 Throw data is based on supply air and room air both at isothermal conditions

- 4 Effective core areas listed in chart are defined as the measurement of space between the blades actually being utilized by the air

- 5 Data obtained from tests conducted in accordance with ANSI/ASHRAE standard 70-2006



Field Adjustable



High Capacity



MRI Compatible



Expedited Service

LOUVERED T-BAR DIFFUSERS



HVD Series 4 Cone T-Bar Diffuser

Standard Features:

- 4 cone steel diffuser with hinged core for easy duct access
- Designed for high volume air delivery
- Delivers supply air in a 360° air pattern
- 2" ADC compliant round collar with bead for ease of installation
- Collar sizes available in 6"-10", 12", 14", and 16"
- Rust resistant pre-coat with durable powder finish
- Soft White

Options:

- Aluminum 4 cone T-Bar diffuser with fixed face
MODEL: AA-HVD
- Adjustable baffle controllers to direct airflow horizontally or vertically
MODEL: HVD-ADJ
- Fits 1x1 ceiling grids (collar size 6"-10")
MODEL: HVD-1x1
- Fixed face 4 cone T-Bar diffuser (available in even sizes 6"-14")
MODEL: FTD
- BD – Field installable Bowtie Damper (available on even sizes 6"-14")
- Square collar
- TVB – Thermal Vapor Blanket
- NGD – Narrow ceiling grid dimples for 9/16" T-Rails, changes O.D. to 23 29/32" (not available on FTD)

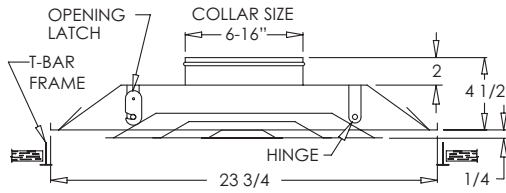

HVD

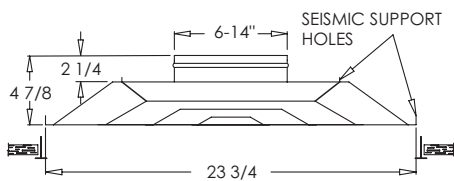

AA-HVD

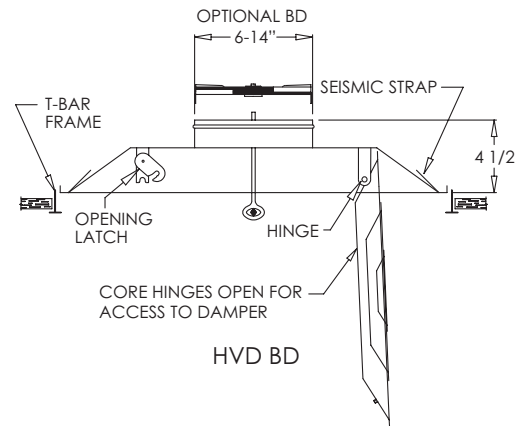

HVD BD

Performance Data: HVD Series

Neck Size	Core Eff. Area (ft ²)	Neck Velocity (FPM) Total Pressure	400	500	600	700	800	900	1000	1200	1400	1600
			0.020	0.035	0.044	0.061	0.078	0.095	0.119	0.175	0.201	0.256
6"	0.195	CFM	78	98	117	137	156	176	195	234	273	312
		NC	<20	<20	<20	<20	20	20-25	25	30-35	35	40
		Throw (ft.)	1 2 4	1 2.5 4.5	2 3 5	2 4 6	3 5 7	3 5 9	4 6 10	5 7 11	6 8 12	7 8 14
7"	0.265	CFM	106	133	159	186	212	239	265	319	372	425
		NC	<20	<20	<20	<20	20	20-25	25	30-35	35-40	40-45
		Throw (ft.)	1 3 5	1 3.5 6	2 4 7	2 5 8	3 7 9.5	4 7 11	5 8 12	6 8.5 13	7 9 14	8 11 16
8"	0.347	CFM	139	173	208	243	277	312	347	416	485	555
		NC	<20	<20	<20	20	20	25	30-35	35-40	40	45
		Throw (ft.)	2 4 6	2 5 7	3 5 9	3 6 10	4 7 12	5 8 13	6 9 14	7 10 15	9 11 16	10 13 18
9"	0.439	CFM	176	219	263	307	351	395	439	527	614	702
		NC	<20	<20	20	25	30	30-35	35	40	40	45
		Throw (ft.)	2 4.5 7	3 5 8	3 6 10	3 6.5 11.5	5 7.5 13	6 8.5 14	7 9.5 15	8 11 17	9 12 18	10 14 20
10"	0.542	CFM	217	271	325	379	433	488	542	650	758	867
		NC	<20	<20	20	25	30	30-35	35	40	40-45	45-50
		Throw (ft.)	2 4 8	4 5 10	4 6 12	4 7 13	6 8 14	7 9 15	8 10 16	9 12 18	10 13 19	11 15 22
12"	0.780	CFM	312	390	468	546	624	702	780	936	1092	1248
		NC	<20	<20	20-25	25-30	30-35	35	35-40	40-45	45	45
		Throw (ft.)	3 5 11	5 7.0 14	5 8 15	5 9 16	7 11 18	8 12 18	10 14 20	11 15 21	12 16 23	13 18 25
14"	1.062	CFM	425	531	637	743	849	956	1062	1274	1486	1699
		NC	<20	25	30	30-35	35-40	40	40-45	45-50	45	50
		Throw (ft.)	4 7 13	6 8 16	6 10 17	7 12 20	8 14 21	10 16 22	12 17 23	13 18 25	14 19 27	16 21 29
16"	1.387	CFM	555	693	832	971	1109	1248	1387	1664	1941	2219
		NC	<20	25	30-35	35	35-40	40-45	40-45	45	45	50
		Throw (ft.)	5 8 16	6 9 17	7 11 18	8 13 21	10 15 23	13 18 25	14 19 27	16 21 28	17 23 31	19 24 33

Performance Notes:

- 1 For square neck multiply CFM × 1.21
- 2 Additional performance data for sizes not listed is available at www.shoemakermfg.com
- 3 Throw values are measured in feet for terminal velocities of 150/100/50 FPM

- 4 Throw data is based on supply air and room air both at isothermal conditions
- 5 Effective core areas listed in chart are defined as the measurement of space between the blades actually being utilized by the air

- 6 Data obtained from tests conducted in accordance with ANSI/ASHRAE standard 70-2006



Field Adjustable



High Capacity



MRI Compatible



Expedited Service

LOUVERED T-BAR DIFFUSERS



HVL Series 3 Cone T-Bar Diffuser

Standard Features:

- 3 cone steel diffuser with hinged core for easy duct access
- Designed for high volume air delivery
- Delivers supply air in a 360° air pattern
- 2" ADC compliant round collar with bead for ease of installation
- Collar sizes available in 6"-10", 12", 14", and 16"
- Rust resistant pre-coat with durable powder finish
- Soft White

Options:

- Aluminum 3 cone T-Bar diffuser with fixed face
MODEL: AA-HVL
- Adjustable baffle controllers to direct airflow horizontally or vertically
MODEL: HVL-ADJ
- Fits 1×1 ceiling grids (collar size 6"-10")
MODEL: HVL-1×1
- BD – Field installable Bowtie Damper (available on even sizes 6"-14")
- Square collar
- TVB – Thermal Vapor Blanket
- NGD – Narrow ceiling grid dimples for 9/16" T-Rails, changes O.D. to 23 29/32"

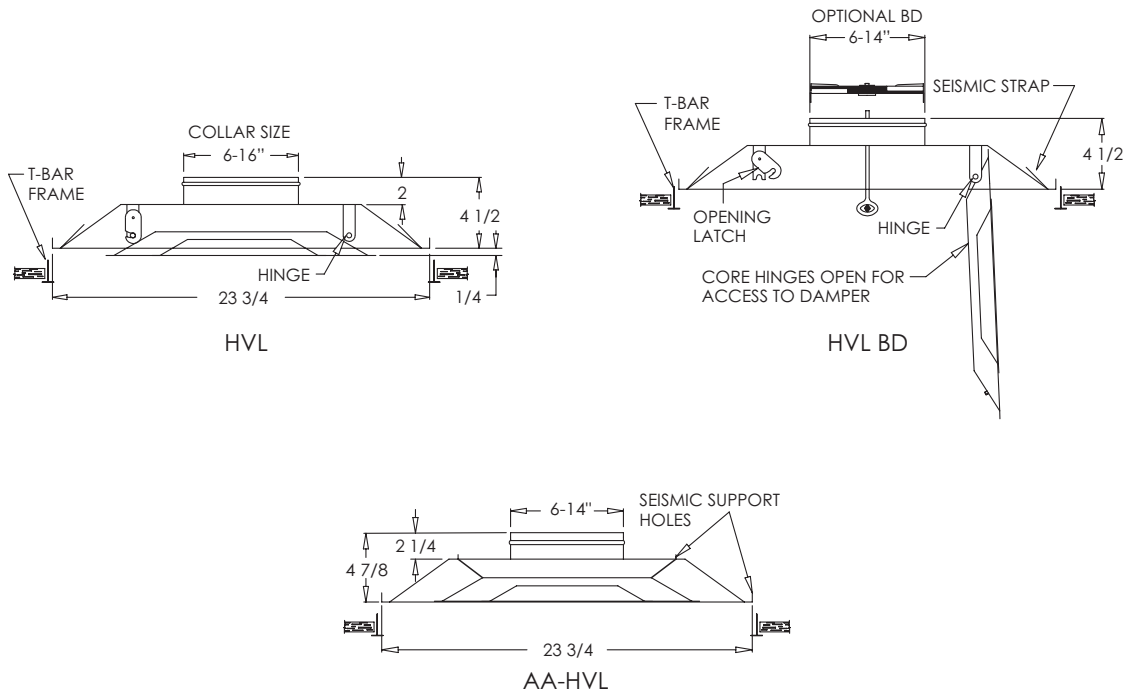

Performance Data: HVL Series

Neck Size	Core Eff. Area (ft ²)	Neck Velocity (FPM) Total Pressure	400	500	600	700	800	900	1000	1200	1400	1600
			0.020	0.035	0.044	0.061	0.078	0.095	0.119	0.175	0.201	0.256
6"	0.195	CFM	78	98	117	137	156	176	195	234	273	312
		NC	<20	<20	<20	<20	20	20-25	25	30-35	35	40
		Throw (ft.)	1 2 4	1 2.5 4.5	2 3 5	2 4 6	3 5 7	3 5 9	4 6 10	5 7 11	6 8 12	7 8 14
7"	0.265	CFM	106	133	159	186	212	239	265	319	372	425
		NC	<20	<20	<20	<20	20	20-25	25	30-35	35-40	40-45
		Throw (ft.)	1 3 5	1 3.5 6	2 4 7	2 5 8	3 6.5 9.5	4 7 11	5 8 12	6 8.5 13	7 9 14	8 11 16
8"	0.347	CFM	139	173	208	243	277	312	347	416	485	555
		NC	<20	<20	<20	20	20	25	30-35	35-40	40	45
		Throw (ft.)	2 4 6	2 5 7	3 5 9	3 6 10	4 7 12	5 8 13	6 9 14	7 10 15	9 11 16	10 13 18
9"	0.439	CFM	176	219	263	307	351	395	439	527	614	702
		NC	<20	<20	20	25	30	30-35	35	40	40	45
		Throw (ft.)	2 4.5 7	3 5 8	3 6 10	3 6.5 11.5	5 7.5 13	6 8.5 14	7 9.5 15	8 11 17	9 12 18	10 14 20
10"	0.542	CFM	217	271	325	379	433	488	542	650	758	867
		NC	<20	<20	20	25	30	30-35	35	40	40-45	45-50
		Throw (ft.)	2 4 8	4 5 10	4 6 12	4 7 13	6 8 14	7 9 15	8 10 16	9 12 18	10 13 19	11 15 22
12"	0.780	CFM	312	390	468	546	624	702	780	936	1092	1248
		NC	<20	<20	20-25	25-30	30-35	35	35-40	40-45	45	45
		Throw (ft.)	3 5 11	5 7 14	5 8 15	5 9 16	7 11 18	8 12 18	10 14 20	11 15 21	12 16 23	13 18 25
14"	1.062	CFM	425	531	637	743	849	956	1062	1274	1486	1699
		NC	<20	25	30	30-35	35-40	40	40-45	45-50	45	50
		Throw (ft.)	4 7 13	6 8 16	6 10 17	7 12 20	8 14 21	10 16 22	12 17 23	13 18 25	14 19 27	16 21 29
16"	1.387	CFM	555	693	832	971	1109	1248	1387	1664	1941	2219
		NC	<20	25	30-35	35	35-40	40-45	40-45	45	45	50
		Throw (ft.)	8 12 16	9 13 17	11 15 18	13 17 21	15 19 23	18 21 24	19 22 25	21 24 28	21 26 31	23 28 33

Performance Notes:

- 1 For square neck multiply CFM × 1.21
- 2 Additional performance data for sizes not listed is available at www.shoemakermfg.com
- 3 Throw values are measured in feet for terminal velocities of 150/100/50 FPM

- 4 Throw data is based on supply air and room air both at isothermal conditions
- 5 Effective core areas listed in chart are defined as the measurement of space between the blades actually being utilized by the air

- 6 Data obtained from tests conducted in accordance with ANSI/ASHRAE standard 70-2006



Field Adjustable



High Capacity



MRI Compatible



Expedited Service

ARCHITECTURAL PLAQUE T-BAR DIFFUSERS



HL Series Architectural Plaque T-Bar Diffuser

Standard Features:

- Single plaque T-Bar diffuser
- Designed for high volume air delivery
- Delivers supply air in a 360° air pattern
- Hinged and removable core for easy duct access
- 2" ADC compliant round collar with bead for ease of installation
- Collar sizes available in 6"-10", 12", 14", & 16"
- Rust resistant pre-coat with durable powder finish
- Soft White

Options:

- Aluminum architectural T-Bar diffuser with fixed plaque face
MODEL: AA-HL
- Adjustable baffle controllers to direct airflow horizontally or vertically
MODEL: HL-ADJ
- Fits 1×1 ceiling grids
MODEL: HL-1×1
- Architectural surface mount plaque diffuser
MODEL: SM-HL
- BD – Field installable Bowtie Damper (available on even sizes 6"-14")
- Square collar
- TVB – Thermal Vapor Blanket
- NGD – Narrow ceiling grid dimples for 9/16" T-Rails, changes O.D. to 23 29/32"

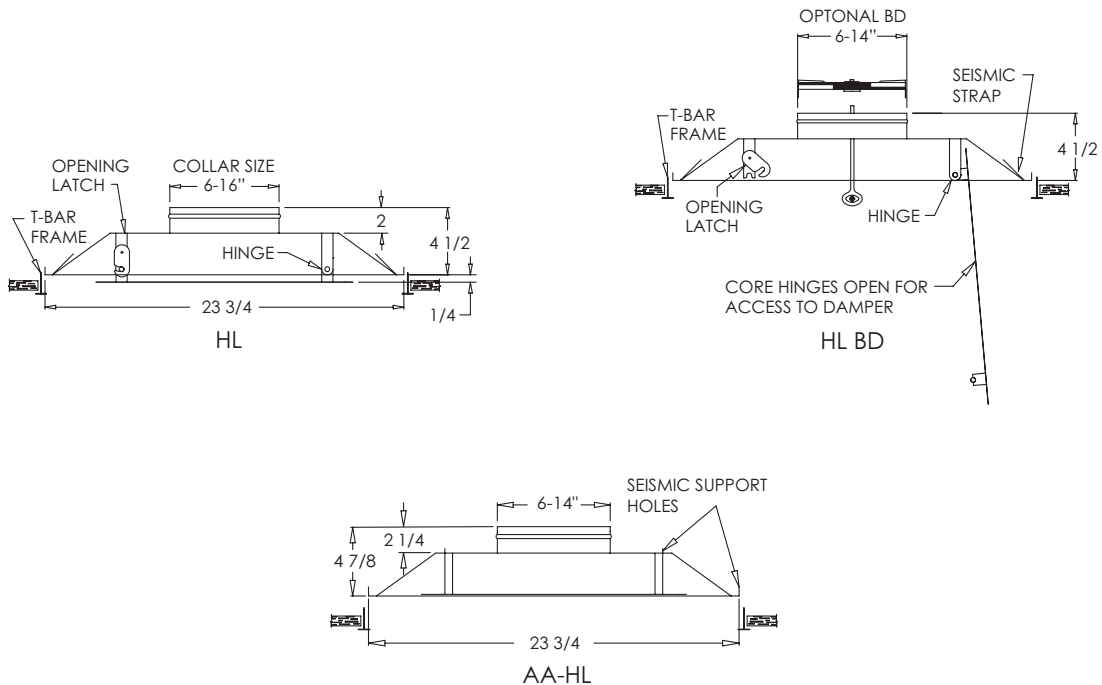

Performance Data: HL Series

Neck Size	Core Eff. Area (ft ²)	Neck Velocity (FPM) Total Pressure	400	500	600	700	800	900	1000	1200	1400	1600
			0.020	0.035	0.044	0.061	0.078	0.095	0.119	0.175	0.201	0.256
6"	0.195	CFM	78	98	117	137	156	176	195	234	273	312
		NC	<20	<20	<20	<20	20	20-25	25	30-35	35	40
		Throw (ft.)	1 2 4	1 2.5 4.5	1 3 5	2 4 6	2 4 7	3 4 8	3 5 9	4 5 11	4 6 12	7 7 13
7"	0.265	CFM	106	133	159	186	212	239	265	319	372	425
		NC	<20	<20	<20	<20	20	20-25	25	30-35	35-40	40-45
		Throw (ft.)	1 3 5	1 3.5 6	1 4 7	2 4 8	3 5 9	4 5 10	4 6 11	5 7 12	5 8 14	8 10 16
8"	0.347	CFM	139	173	208	243	277	312	347	416	485	555
		NC	<20	<20	<20	20	20	25	30-35	35-40	40	45
		Throw (ft.)	2 3 6	2 4 7	3 4 9	3 5 10	4 6 10	5 6 12	5 7 13	6 9 14	7 10 16	10 12 19
9"	0.439	CFM	176	219	263	307	351	395	439	527	614	702
		NC	<20	<20	20	25	30	30-35	35	40	40	45
		Throw (ft.)	2 4 6.5	2 5 8	3 5 10	4 6 11	4 7 12	5 8 13	6 9 14	7 10 16	8 12 18	11 13 20
10"	0.542	CFM	217	271	325	379	433	488	542	650	758	867
		NC	<20	<20	20	25	30	30-35	35	40	40-45	45-50
		Throw (ft.)	3 4 8	3 5 10	4 6 12	5 7 13	5 8 14	6 9 15	7 10 16	8 12 18	10 13 19	12 15 22
12"	0.780	CFM	312	390	468	546	624	702	780	936	1092	1248
		NC	<20	<20	20-25	25-30	30-35	35	35-40	40-45	45-50	>50
		Throw (ft.)	4 5 11	5 7 14	6 8 15	7 9 16	8 11 17	9 12 18	10 14 19	11 15 21	13 16 24	13 18 26
14"	1.062	CFM	425	531	637	743	849	956	1062	1274	1486	1699
		NC	<20	25	30	30-35	35-40	40	40-45	45-50	45-50	>50
		Throw (ft.)	5 7 13	6 8 16	8 10 17	9 12 19	10 13 20	11 15 21	12 16 23	13 17 25	15 19 27	16 22 30
16"	1.387	CFM	555	693	832	971	1109	1248	1387	1664	1941	2219
		NC	<20	25	30-35	35	35-40	40-45	40-45	45-50	45-50	>50
		Throw (ft.)	9 12 15	10 14 18	12 15 18	14 17 21	15 19 22	17 20 23	18 21 25	19 23 27	21 25 29	25 29 34

Performance Notes:

- 1 For square neck multiply CFM × 1.21
- 2 Additional performance data for sizes not listed is available at www.shoemakermfg.com
- 3 Throw values are measured in feet for terminal velocities of 150/100/50 FPM

- 4 Throw data is based on supply air and room air both at isothermal conditions
- 5 Effective core areas listed in chart are defined as the measurement of space between the blades actually being utilized by the air

6 Data obtained from tests conducted in accordance with ANSI/ASHRAE standard 70-2006



Field Adjustable



High Capacity



MRI Compatible



Expedited Service

PERFORATED T-BAR DIFFUSERS

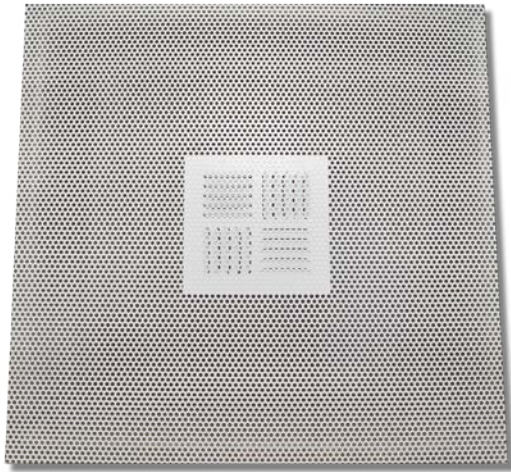

110 Series Perforated Fiberglass Back T-Bar Diffuser

Standard Features:

- Perforated face with 4-way fixed air pattern controller
- 3/16" holes on 1/4" staggered centers
- Preformed, contour molded fiberglass back with a foil barrier backing, accepts 6"-16" collar (collar by others)
- Rust resistant pre-coat with durable powder finish
- Soft White

Options:

- Return air grille without deflector grid

MODEL: 111

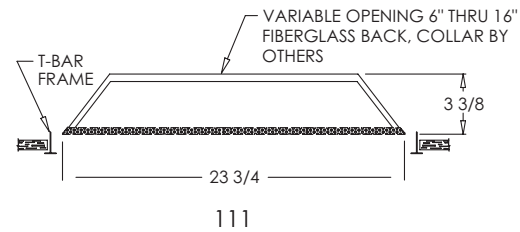
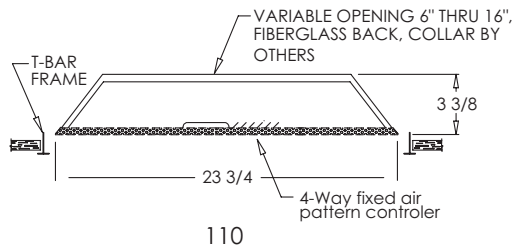

Performance Data: 110 Series

Neck Size	Core Eff. Area (ft ²)	Neck Velocity (FPM) Velocity Pressure	300	400	500	600	700	800	900	1000	1200
			0.007	0.011	0.017	0.024	0.032	0.044	0.056	0.067	0.095
6"	0.188	CFM	56	75	94	113	131	150	169	188	225
		NC	<20	<20	<20	<20	<20	<20	20	20	20
		Throw (ft.)	1 2 4	2 3 6	3 4 8	4 5 9	5 6 10	5 7 12	6 7 13	7 10 15	8 9 16
8"	0.333	CFM	100	133	167	200	233	267	300	333	400
		NC	<20	<20	<20	<20	<20	<20	20	20	25
		Throw (ft.)	2 3 5	3 4 7	4 5 9	5 6 10	6 7 12	6 7 13	7 8 15	8 12 16	9 10 18
10"	0.521	CFM	156	208	260	313	365	417	469	521	625
		NC	<20	<20	<20	<20	<20	<20	20	25	25
		Throw (ft.)	3 3 7	4 5 8	5 6 10	6 7 12	7 9 14	8 10 16	9 11 17	10 14 18	10 12 20
12"	0.750	CFM	225	300	375	450	525	600	675	750	900
		NC	<20	<20	<20	<20	<20	20	25	25	30
		Throw (ft.)	4 6 11	5 7 14	7 9 15	8 10 17	9 11 19	11 13 20	12 15 22	12 15 23	14 17 25
14"	1.021	CFM	306	408	510	613	715	817	919	1021	1225
		NC	<20	<20	<20	<20	<20	20	25	25-30	30
		Throw (ft.)	4 6 13	6 9 15	9 12 18	10 13 20	11 14 22	13 16 24	14 17 27	14 18 28	16 20 30
16"	1.333	CFM	400	533	667	800	933	1067	1200	1333	1600
		NC	<20	<20	<20	<20	20	25	25	25-30	30-35
		Throw (ft.)	5 7 15	8 11 17	11 14 20	12 14 23	13 16 26	15 19 28	16 20 30	17 22 32	18 24 34

Performance Notes:

1 Throw values are measured in feet for terminal velocities of 150/100/50 FPM

2 Throw data is based on supply air and room air both at isothermal conditions

3 Data obtained from tests conducted in accordance with ANSI/ASHRAE standard 70-2006

Performance Data: 111 Series

Neck Size	Core Eff. Area (ft ²)	Neck Velocity (FPM) Velocity Pressure	200	300	400	500	600	700	800	900	1000	1200
			0.006	0.018	0.032	0.048	0.070	0.092	0.120	0.140	0.160	0.230
6"	0.195	CFM	39	59	78	98	117	137	156	176	195	234
		NC	<20	<20	<20	<20	<20	<20	<20	20	20-25	25-30
7"	0.265	CFM	53	80	106	133	159	186	212	239	265	319
		NC	<20	<20	<20	<20	<20	<20	<20	20	20-25	25-30
8"	0.347	CFM	69	104	139	173	208	243	277	312	347	416
		NC	<20	<20	<20	<20	<20	<20	<20	20-25	20-25	25-30
9"	0.439	CFM	88	132	176	219	263	307	351	395	439	527
		NC	<20	<20	<20	<20	<20	<20	<20	20-25	20-25	25-30
10"	0.542	CFM	108	163	217	271	325	379	433	488	542	650
		NC	<20	<20	<20	<20	<20	<20	<20	20-25	20-25	25-30
12"	0.780	CFM	156	234	312	390	468	546	624	702	780	936
		NC	<20	<20	<20	<20	<20	<20	<20	20-25	25-30	30
14"	1.062	CFM	212	319	425	531	637	743	849	956	1062	1274
		NC	<20	<20	<20	<20	<20	<20	<20	20-25	25-30	30
16"	1.387	CFM	277	416	555	693	832	971	1109	1248	1387	1664
		NC	<20	<20	<20	<20	<20	<20	20-25	20-25	25-30	30-35

Performance Notes:

1 Data obtained from tests conducted in accordance with ANSI/ASHRAE standard 70-2006



Field Adjustable



High Capacity



MRI Compatible



Expedited Service

PERFORATED T-BAR DIFFUSERS

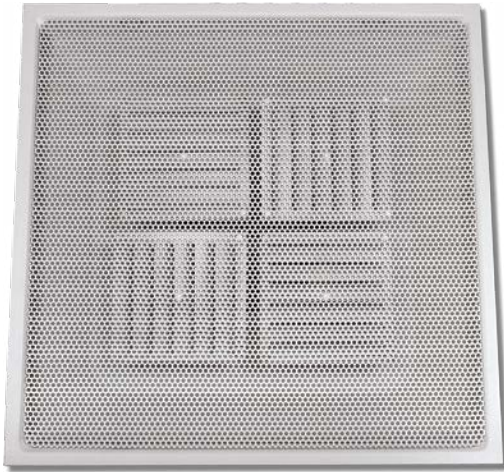

780 Series Perforated T-Bar with Adjustable Pattern Controllers

Standard Features:

- Perforated face with adjustable pattern controllers
- Spring push release hinge down face
- Airflow can be adjusted to 1, 2, 3 or 4-way air patterns
- 3/16" holes on 1/4" staggered centers
- 2" ADC compliant round collar with bead for ease of installation
- Rust resistant pre-coat with durable powder finish
- Soft White

Options:

- Preformed, contour molded fiberglass back with a foil barrier backing, accepts 6"-16" collar (collar by others.) Fixed perforated face, not removable.

MODEL: 781

- BD – Field installable Bowtie Damper, available on even sizes 6"-14"
- Square Collar
- Black pan – back pan powder coated black to reduce visibility into ductwork
- TVB – Thermal Vapor Blanket
- NGD – Narrow ceiling grid dimples for 9/16" T-Rails, changes O.D. to 23 29/32"

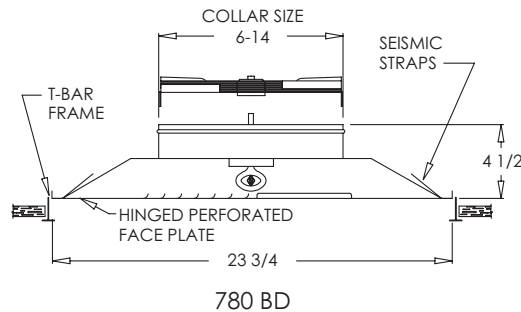
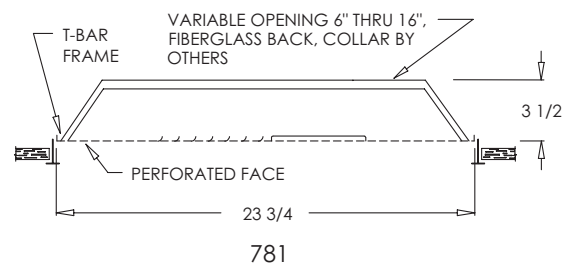
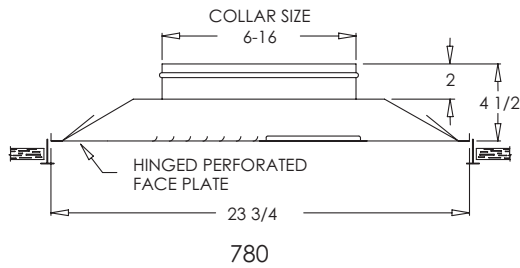

Performance Data: 780 Series

Neck Size	Core Eff. Area (ft ²)	Neck Velocity (FPM)	400		500			600			700			800			1000			
			Total Pressure			CFM			NC			Throw (ft.)			CFM			NC		
6"	0.195	Total Pressure	0.038			0.108			0.155			0.220			0.285			0.438		
		CFM	78			98			117			137			156			195		
		NC	<20			<20			<20			<20			<20			20		
		Throw (ft.)	2	3	6	3	4	8	4	5	9	5	6	10	5	7	12	7	10	15
8"	0.347	CFM	139			173			208			243			277			347		
		NC	<20			<20			<20			<20			<20			20		
		Throw (ft.)	3	5	7	4	5	9	5	6	10	6	8	12	6	8	13	8	12	16
		CFM	217			271			325			379			433			542		
10"	0.542	NC	<20			<20			<20			<20			<20			25		
		Throw (ft.)	4	6	8	5	7	10	6	8	12	7	10	16	8	10	16	10	14	18
		CFM	312			390			468			546			624			780		
		NC	<20			<20			<20			<20			20			25		
12"	0.780	Throw (ft.)	5	7	14	7	9	15	8	10	17	9	11	19	11	13	20	12	15	23
		CFM	425			531			637			743			849			1062		
		NC	<20			<20			<20			<20			20			25-30		
		Throw (ft.)	6	9	15	9	12	18	10	13	20	11	14	22	13	16	24	14	18	28
14"	1.062	CFM	555			693			832			971			1109			1387		
		NC	<20			<20			<20			20			25			25-30		
		Throw (ft.)	8	11	17	11	14	20	12	14	23	13	16	26	15	19	28	17	22	32
		CFM	425			531			637			743			849			1062		

Performance Notes:

1 For square neck multiply CFM × 1.21
 2 Additional performance data for sizes not listed is available at www.shoemakerfmg.com

3 Throw values are measured in feet for terminal velocities of 150/100/50 FPM
 4 Throw data is based on supply air and room air both at isothermal conditions

5 Data obtained from tests conducted in accordance with ANSI/ASHRAE standard 70-2006



Field Adjustable



High Capacity



MRI Compatible



Expedited Service

PERFORATED T-BAR DIFFUSERS



104P Series Perforated Curved Blade T-Bar Diffuser

Standard Features:

- Perforated face with stamped 4-way curved blade T-Bar diffuser
- 3/16" holes on 1/4" staggered centers
- Five air patterns available
- 2" ADC compliant round collar with bead for ease of installation
- Standard collar diameter is 2" smaller than face (ex. 12x12 face has a 10" collar)
- Rust resistant pre-coat with durable powder finish
- Soft White

Options:

- Lever operated Multi-Shutter Damper
MODEL: 104P-D
- Lever operated Opposed Blade Damper
MODEL: 104P-O
- Square Collar
- TVB – Thermal Vapor Blanket
- NGD – Narrow ceiling grid dimples for 9/16" T-Rails, changes O.D. to 23 29/32"

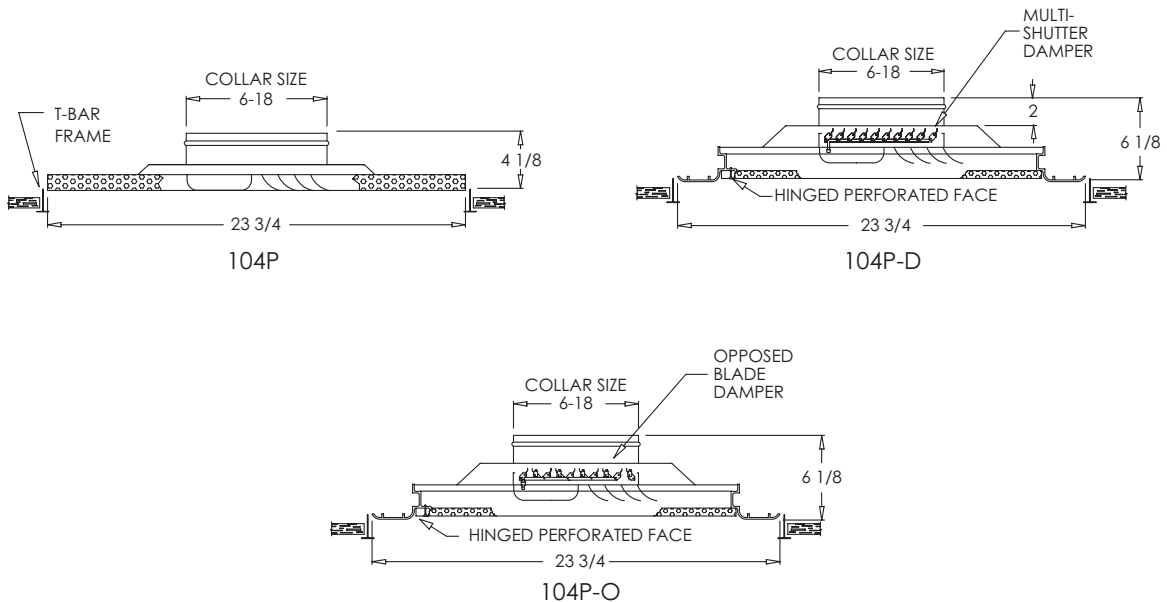

Air Patterns:

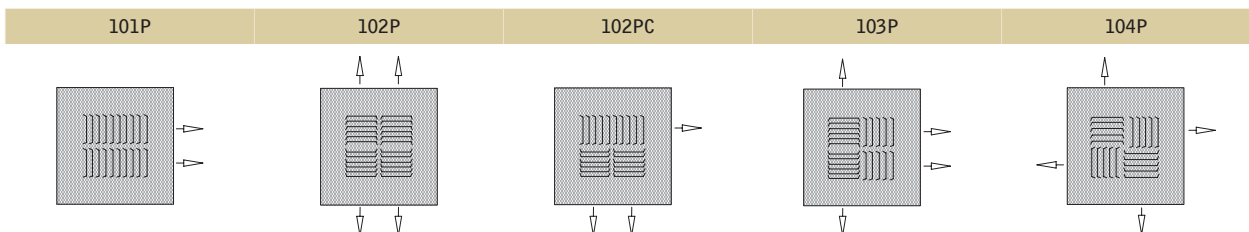

Performance Data: 104P Series

Neck Size	Core Eff. Area (ft ²)	Neck Velocity (FPM) Velocity Pressure	300	400	500	600	700	800	900	1000
			0.007	0.011	0.017	0.024	0.032	0.044	0.056	0.067
8×8-6	0.169	CFM	51	67	84	101	118	135	152	169
		NC	<20	20-25	25-30	30	35	35-40	40	45
		Throw (ft.)	2 3 4	3 4 5.5	4 5 6.5	5 6 8	6 7 10	7 8 11	8 9 13	9 10 14
10×10-8	0.313	CFM	94	125	157	188	219	251	282	313
		NC	<20	20-25	25-30	30	35	35-40	40	45
		Throw (ft.)	3 3.5 4.5	4 4.5 6	5 5.5 7	6 6.5 8.5	7 7.5 10.5	8 9 12	9 10 14	10 11 17
12×12-10	0.503	CFM	151	201	252	302	352	403	453	503
		NC	20	25-30	30	30	<40	40-45	45	45
		Throw (ft.)	4 4.5 5.5	5 5 7	6 6.5 9	7 7.5 10.5	8 9.5 12.5	9 10.5 14.5	10 11 16	11 12 18
14×14-12	0.739	CFM	222	296	369	443	517	591	665	739
		NC	20	25-30	30	30-35	<40	40-45	45	50
		Throw (ft.)	5 5.5 6.5	6 7 8.5	7 7.5 10.5	8 9 13	10 11 15	10 12 16	12 15 21	13 15 23
16×16-14	1.020	CFM	306	408	510	612	714	816	918	1020
		NC	25	25-30	30	35	35-40	45	<50	50
		Throw (ft.)	5 5.5 7.5	7 7.5 9.5	8 8.5 11.5	9 11.5 15	12 14 18	12 14 19	14 17 23	15 17 26
18×18-16	1.316	CFM	395	526	658	790	921	1053	1185	1316
		NC	25-30	30	30-35	35-40	40	45	50	>50
		Throw (ft.)	6 7 8.5	8 8.5 10.5	9 9 13	10 12 16	13 14 20	14 16 22	16 18 25	16 18 28

Performance Notes:

1 For square neck multiply CFM × 1.21
 2 Additional performance data for sizes not listed is available at www.shoemakermfg.com

3 Throw values are measured in feet for terminal velocities of 150/100/50 FPM
 4 Throw data is based on supply air and room air both at isothermal conditions

5 Data obtained from tests conducted in accordance with ANSI/ASHRAE standard 70-2006



Field Adjustable



High Capacity



MRI Compatible



Expedited Service

PERFORATED T-BAR DIFFUSERS

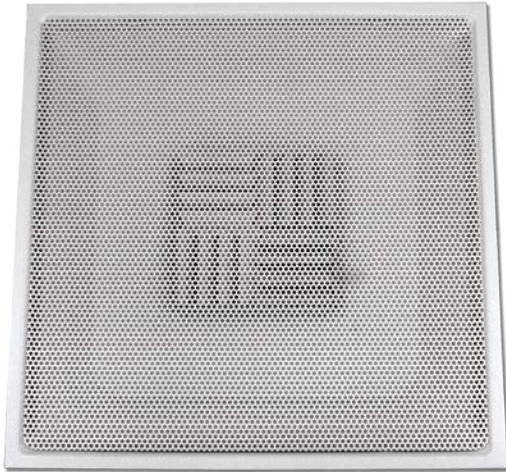

825 Series Perforated Curved Blade T-Bar Diffuser

Standard Features:

- Modular core (825MA) or adjustable curved blade (825CB) diffuser
- Nylon bushings on adjustable blades prevent metal on metal rattle (825CB)
- Hinged perforated face with spring push release for easy access
- 3/16" holes on 1/4" staggered centers
- 2" ADC compliant round collar with bead for ease of installation
- Collar available in sizes 6"-10", 12", 14" and 16"
- Rust resistant pre-coat with durable powder finish
- Soft White

Options:

- Moveable modular cores
MODEL: 825MA
- Adjustable curved blades
MODEL: 825CB
- BD – Field installable Bowtie Damper, available on sizes 6"-14"
- Square Collar
- Black pan – back pan powder coated black to reduce visibility into ductwork
- TVB – Thermal Vapor Blanket
- NGD – Narrow ceiling grid dimples for 9/16" T-Rails, changes O.D. to 23 29/32"

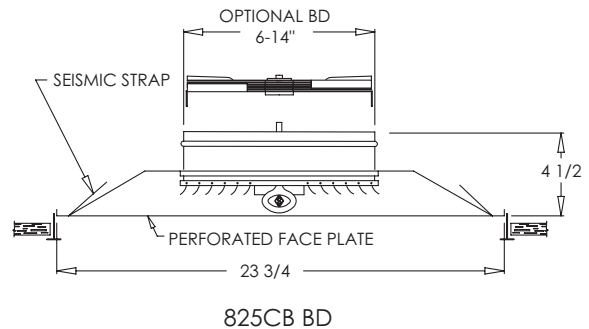
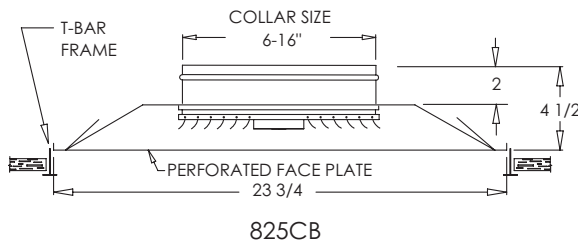
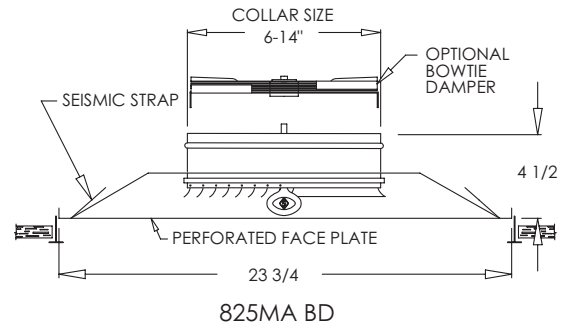
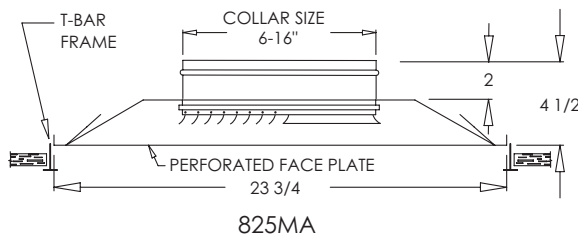

Performance Data: 825 Series

Neck Size	Core Eff. Area (ft²)	Neck Velocity (FPM) Velocity Pressure	300	400	500	600	700	800	900	1000
			0.007	0.011	0.017	0.024	0.032	0.044	0.056	0.067
6"	0.195	CFM	59	78	98	117	137	156	176	195
		NC	<20	<20	<25	25	<30	30	<35	35
		Throw (ft.)	1 2 4	2 3 6	3 4 8	4 5 9	5 6 10	5 7 12	6 7 13	7 10 15
8"	0.347	CFM	104	139	173	208	243	277	312	347
		NC	<20	<20	<20	<20	<20	<20	20	20
		Throw (ft.)	2 3 5	3 4 7	4 5 9	5 6 10	6 7 12	6 7 13	7 8 15	8 12 16
10"	0.542	CFM	163	217	271	325	379	433	488	542
		NC	<20	<20	<20	<20	<20	<20	20	25
		Throw (ft.)	3 3 7	4 5 8	5 6 10	6 7 12	7 9 16	8 10 16	9 11 17	10 14 18
12"	0.780	CFM	234	312	390	468	546	624	702	780
		NC	<20	<20	<20	<20	<20	20	25	25
		Throw (ft.)	4 6 11	5 7 14	7 9 15	8 10 17	9 11 19	11 13 20	12 15 22	12 15 23
14"	1.062	CFM	319	425	531	637	743	849	956	1062
		NC	<20	<20	<20	<20	<20	20	25	25-30
		Throw (ft.)	4 6 13	6 9 15	9 12 18	10 13 20	11 14 22	13 16 24	14 17 27	14 18 28
16"	1.387	CFM	416	555	693	832	971	1109	1248	1387
		NC	<20	<20	<20	<20	20	25	25	25-30
		Throw (ft.)	5 7 15	8 11 17	11 14 20	12 14 23	13 16 26	15 19 28	16 20 30	17 22 32

Performance Notes:

1 For square neck multiply CFM × 1.21
 2 Additional performance data for sizes not listed is available at www.shoemakermfg.com

3 Throw values are measured in feet for terminal velocities of 150/100/50 FPM
 4 Throw data is based on supply air and room air both at isothermal conditions

5 Data obtained from tests conducted in accordance with ANSI/ASHRAE standard 70-2006



Field Adjustable



High Capacity



MRI Compatible



Expedited Service

PERFORATED T-BAR RETURN



PT Series Perforated T-Bar

Standard Features:

- 2×2 perforated T-Bar lay-in
- 3/16" holes on 1/4" staggered centers
- 58% free area
- Heavy gauge steel
- Rust resistant pre-coat with durable powder finish
- Soft White

Options:

- Framed perforated T-Bar
MODEL: 600PT
- 1×1 T-Bar
- 1×2 T-Bar
- 2×4 T-Bar

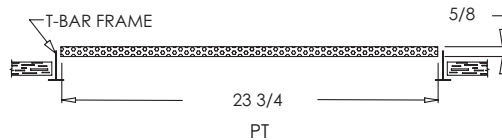

Performance Data: PT Series

Neck Size	Core Eff. Area (ft ²)	Neck Velocity (FPM) Velocity Pressure	300	400	500	600	700	800	900	1000
			CFM	318	424	530	636	742	848	954
1×2	1.060	NC	<20	<20	<20	<20	20	20-25	25	25-30
		CFM	636	848	1060	1272	1484	1696	1908	2120
2×2	2.120	NC	<20	<20	<20	<20	20	20-25	25	25-30
		CFM	1272	1696	2120	2544	2968	3392	3816	4240
2×4	4.240	NC	<20	<20	20	20	20-25	25-30	30	30-35

Performance Notes:

1 Data obtained from tests conducted in accordance with ANSI/ASHRAE standard 70-2006

PERFORATED T-BAR RETURN



105P Series Fixed Perforated T-Bar Return Grille

Standard Features:

- Fixed perforated face with 3/16" holes on 1/4" staggered centers
- 2" ADC compliant round collar with bead for ease of installation
- Rust resistant pre-coat with durable powder finish
- Soft White

Options:

- Lever operated Multi-Shutter Damper
MODEL: 105P-D
- Lever operated Opposed Blade Damper
MODEL: 105P-0
- Square Collar
- TVB – Thermal Vapor Blanket

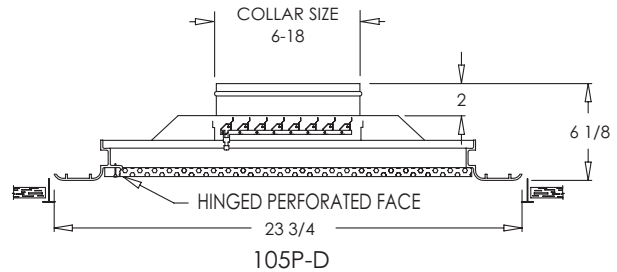
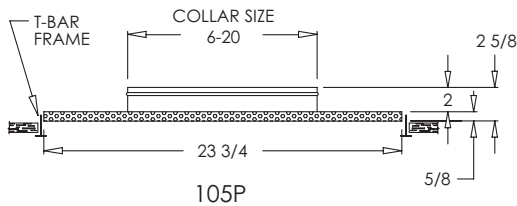

Performance Data: 105P Series

Neck Size	Core Eff. Area (ft ²)	Neck Velocity (FPM) Total Pressure	200	300	400	500	600	700	800	900	1000	1200
			0.006	0.018	0.032	0.048	0.070	0.092	0.120	0.140	0.160	0.230
6"	0.195	CFM	39	59	78	98	117	137	156	176	195	234
		NC	<20	<20	20	20	20-25	25	25-30	25-30	30	35
7"	0.265	CFM	53	80	106	133	159	186	212	239	265	319
		NC	<20	<20	20	20	20-25	25	25-30	25-30	30	35
8"	0.347	CFM	69	104	139	173	208	243	277	312	347	416
		NC	<20	20	20	20-25	25	25	25-30	30	30	35
9"	0.439	CFM	88	132	176	219	263	307	351	395	439	527
		NC	<20	20	20	20-25	25	25	25-30	30	30	35
10"	0.542	CFM	108	163	217	271	325	379	433	488	542	650
		NC	<20	20	20-25	20-25	25	25	30	30	35	35
12"	0.780	CFM	156	234	312	390	468	546	624	702	780	936
		NC	<20	20	20-25	20-25	25	25	30	30	35	35
14"	1.062	CFM	212	319	425	531	637	743	849	956	1062	1274
		NC	<20	20	20-25	25	25	25-30	30	30-35	35	40
16"	1.387	CFM	277	416	555	693	832	971	1109	1248	1387	1664
		NC	<20	20	20-25	25	25	25-30	30	30-35	35	40
18"	1.755	CFM	351	527	702	878	1053	1229	1404	1580	1755	2106
		NC	<20	20-25	25	25-30	30	30	30-35	35	35-40	40

Performance Notes:

1 For square neck multiply CFM × 1.21

2 Data obtained from tests conducted in accordance with ANSI/ASHRAE standard 70-2006



Field Adjustable



High Capacity



MRI Compatible



Expedited Service

PERFORATED T-BAR RETURN

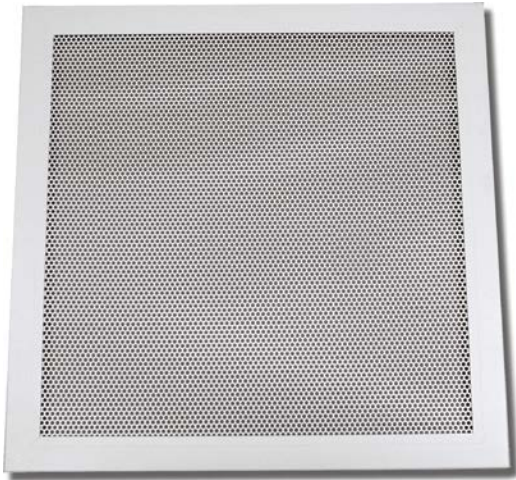

600PT Series Perforated Return Air T-Bar with Frame

Standard Features:

- 3/16" holes on 1/4" staggered centers
- Extruded aluminum frame with signature line marks
- Perforated material 58% free area
- Square collar designed for 22" x 22" duct
- Rust resistant pre-coat with durable powder finish
- Soft White

Options:

- Recessed screwdriver operated Opposed Blade Damper
MODEL: 600PT-0
- Preformed, contour molded fiberglass back with a foil barrier backing
MODEL: 601PT
- 2" ADC compliant round collar with bead for ease of installation
- 1 x 2 T-Bar (10" x 22" duct)
- 2 x 4 T-Bar (22" x 46" duct)

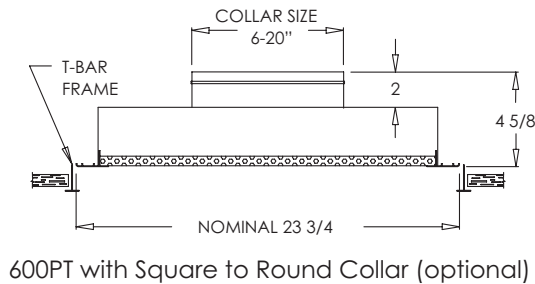
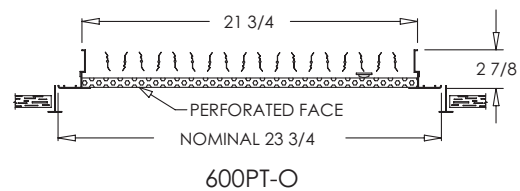

Performance Data: 600PT Series

Neck Size	Core Eff. Area (ft ²)	Neck Velocity (FPM) Velocity Pressure	300	400	500	600	700	800	900	1000
			0.018	0.032	0.048	0.070	0.092	0.120	0.140	0.160
10 x 10	0.258	CFM	77	103	129	155	181	207	232	258
		NC	<20	<20	<20	<20	<20	<20	20-25	25
10 x 22	0.628	CFM	188	251	314	377	440	502	565	628
		NC	<20	<20	<20	<20	20	20-25	25	25-30
22 x 22	1.528	CFM	458	611	764	917	1070	1222	1375	1528
		NC	<20	<20	<20	<20	20	20-25	25	25-30
22 x 46	3.328	CFM	998	1331	1664	1997	2329	2662	2995	3328
		NC	<20	<20	20	20	25-29	25-30	30	30-35

Performance Notes:

1 Data obtained from tests conducted in accordance with ANSI/ASHRAE standard 70-2006

PERFORATED T-BAR RETURN

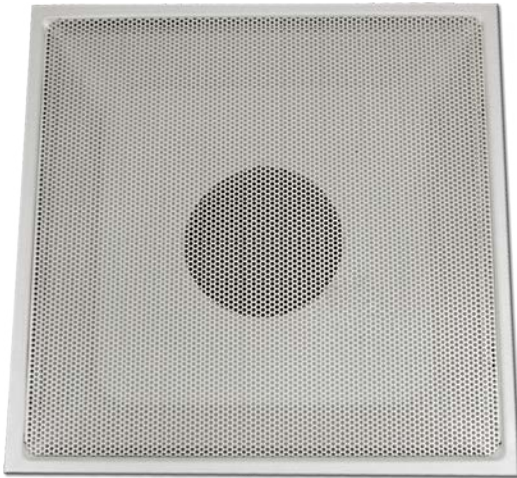

830 Series Hinged Perforated T-Bar Return

Standard Features:

- 3/16" holes on 1/4" staggered centers
- Hinged perforated face with spring push release for easy access to duct
- 2" ADC compliant round collar with bead for ease of installation
- Collar available in sizes 6"-10" and even sizes 12"-20"
- Soft White

Options:

- BD – Field installable Bowtie Damper, available on sizes 6"-14"
- Square Collar
- Black pan – back pan powder coated black to reduce visibility into ductwork
- TVB – Thermal Vapor Blanket
- NGD – Narrow ceiling grid dimples for 9/16" T-Rails, changes O.D. to 23 29/32"

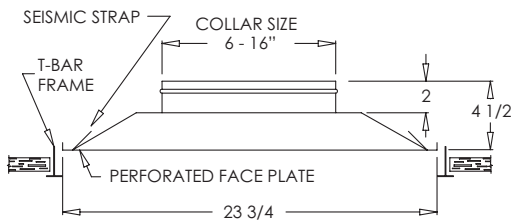

830

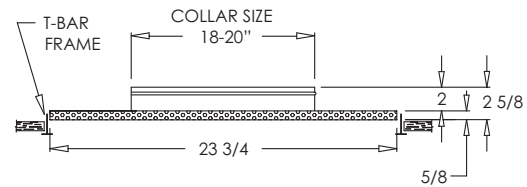

830
(18" & 20" COLLAR ONLY)

Performance Data: 830 Series

Neck Size	Core Eff. Area (ft ²)	Neck Velocity (FPM) Total Pressure	200	300	400	500	600	700	800	900	1000	1200
			0.006	0.018	0.032	0.048	0.070	0.092	0.120	0.140	0.160	0.230
6"	0.195	CFM	39	59	78	98	117	137	156	176	195	234
		NC	<20	<20	<20	<20	<20	<20	<20	20	20-25	25-30
7"	0.265	CFM	53	80	106	133	159	186	212	239	265	319
		NC	<20	<20	<20	<20	<20	<20	<20	20	20-25	25-30
8"	0.347	CFM	69	104	139	173	208	243	277	312	347	416
		NC	<20	<20	<20	<20	<20	<20	<20	20-25	20-25	25-30
9"	0.439	CFM	88	132	176	219	263	307	351	395	439	527
		NC	<20	<20	<20	<20	<20	<20	<20	20-25	20-25	25-30
10"	0.542	CFM	108	163	217	271	325	379	433	488	542	650
		NC	<20	<20	<20	<20	<20	<20	<20	20-25	20-25	25-30
12"	0.780	CFM	156	234	312	390	468	546	624	702	780	936
		NC	<20	<20	<20	<20	<20	<20	<20	20-25	20-25	25-30
14"	1.062	CFM	212	319	425	531	637	743	849	956	1062	1274
		NC	<20	<20	<20	<20	<20	<20	<20	20-25	20-25	25-30
16"	1.387	CFM	277	416	555	693	832	971	1109	1248	1387	1664
		NC	<20	<20	<20	<20	20	20	20-25	25	30	35

Performance Notes:

1 For square neck multiply CFM × 1.21

2 Data obtained from tests conducted in accordance with ANSI/ASHRAE standard 70-2006



Field Adjustable



High Capacity



MRI Compatible



Expedited Service

PERFORATED T-BAR RETURN



700-600P Series Perforated Return Air Grille in T-Bar Panel

Standard Features:

- Perforated return air grille
- 3/16" holes on 1/4" staggered centers
- Extruded aluminum frame with signature line marks fixed in a T-Bar panel
- 2" ADC compliant round collar with bead for ease of installation
- Rust resistant pre-coat with durable powder finish
- Soft White

Options:

- Recessed screwdriver operated Opposed Blade Damper
MODEL: 700-600P-0
- Square Collar
- TVB – Thermal Vapor Blanket
- NGD – Narrow ceiling grid dimples for 9/16" T-Rails, changes O.D. to 23 29/32"

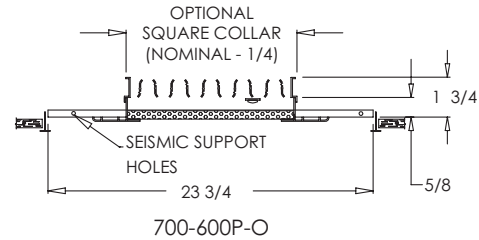
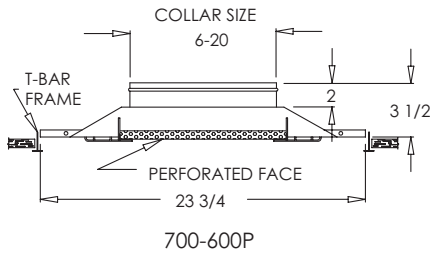

Performance Data: 700-600P Series

Neck Size	Core Eff. Area (ft ²)	Neck Velocity (FPM) Velocity Pressure	300	400	500	600	700	800	900	1000	1200
			0.018	0.032	0.048	0.070	0.092	0.120	0.140	0.160	0.230
6×6-6	0.092	CFM	28	37	46	55	64	74	83	92	110
		NC	<20	<20	<20	<20	20	20-25	25	25-30	30
8×8-8	0.171	CFM	51	68	86	103	120	137	154	171	205
		NC	<20	<20	<20	20	20-25	25	25-30	30	30
10×10-10	0.275	CFM	82	110	137	165	192	220	247	275	329
		NC	<20	<20	<20	20	20-25	25	25-30	30	30
12×12-12	0.402	CFM	121	161	201	241	282	322	362	402	483
		NC	<20	<20	20	20-25	25	25-30	30	35	35-40
14×14-14	0.554	CFM	166	222	277	333	388	443	499	554	665
		NC	<20	<20	20	20-25	25	25-30	30	35	35-40
16×16-16	0.731	CFM	219	292	365	438	512	585	658	731	877
		NC	<20	<20	20	20-25	25	25-30	30	35-40	35-40
18×18-18	0.932	CFM	279	373	466	559	652	745	838	932	1118
		NC	<20	20	20-25	20-25	25	25-30	30	35-40	35-40
20×20-20	1.157	CFM	347	463	578	694	810	925	1041	1157	1388
		NC	<20	20	20-25	20-25	25	25-30	30	35-40	35-40

Performance Notes:

1 For square neck multiply CFM × 1.21

2 Additional performance data for sizes not listed is available at www.shoemakermtg.com

3 Data obtained from tests conducted in accordance with ANSI/ASHRAE standard 70-2006

LATTICE T-BAR RETURN

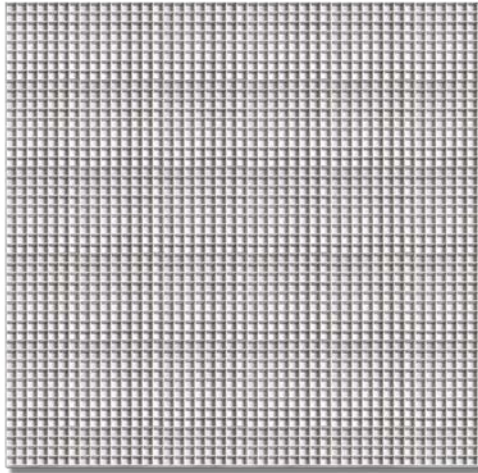

AL Series Aluminum Lattice Return T-Bar

Standard Features:

- Aluminum lattice T-Bar lay-in return air grille
- 1/2" × 1/2" × 1/2" lattice
- 90% free area
- Soft White

Options:

- 1/2" × 1/2" × 1" Lattice
- 1" × 1" × 1" Lattice
- 1×1 T-Bar
- 1×2 T-Bar
- 2×4 T-Bar
- 6" × 24" T-Bar

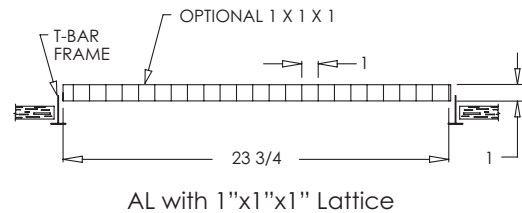
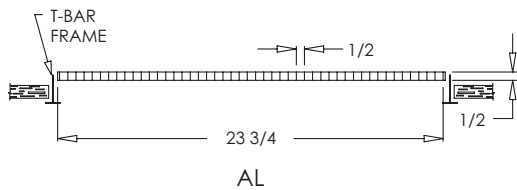

Performance Data: AL Series

Neck Size	Core Eff. Area (ft ²)	Neck Velocity (FPM) Velocity Pressure	300	400	500	600	700	800	900	1000
			0.018	0.032	0.048	0.070	0.092	0.120	0.140	0.160
6"×24"	0.900	CFM	270	360	450	540	630	720	810	900
		NC	<20	<20	<20	<20	<20	<20	20	25
1'×1'	0.900	CFM	270	360	450	540	630	720	810	900
		NC	<20	<20	<20	<20	<20	<20	20	25
1'×2'	1.800	CFM	540	720	900	1080	1260	1440	1620	1800
		NC	<20	<20	<20	<20	<20	<20	20	25
2'×2'	3.600	CFM	1080	1440	1800	2160	2520	2880	3240	3600
		NC	<20	<20	<20	<20	<20	<20	20	25
2'×4'	7.200	CFM	2160	2880	3600	4320	5040	5760	6480	7200
		NC	<20	<20	<20	<20	<20	<20	20	25-30

Performance Notes:

1 Additional performance data for sizes not listed is available at www.shoemakermfg.com

2 Data obtained from tests conducted in accordance with ANSI/ASHRAE standard 70-2006



Field Adjustable



High Capacity



MRI Compatible



Expedited Service

LATTICE T-BAR RETURN

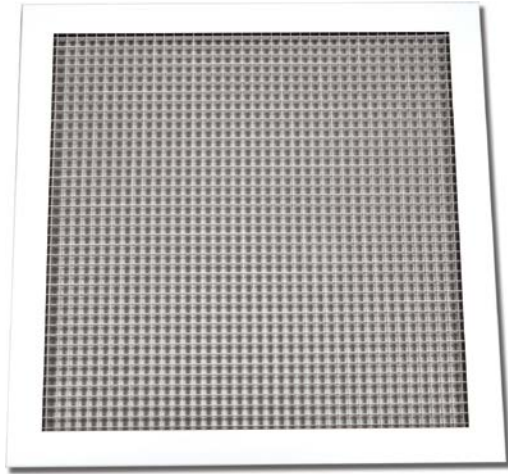

600T Series Aluminum Lattice Return Air Grille T-Bar with Frame

Standard Features:

- $1/2'' \times 1/2'' \times 1/2''$ Aluminum lattice T-Bar lay-in return air grille
- Extruded aluminum frame with signature line marks
- Lattice material 90% free area
- Square collar designed for $22'' \times 22''$ duct
- Rust resistant pre-coat with durable powder finish
- Soft White

Options:

- Recessed screwdriver operated Opposed Blade Damper
MODEL: 600T-0
- $1/2'' \times 1/2'' \times 1/2''$ 45° aluminum lattice
MODEL: 645T
- Preformed, contour molded fiberglass back with a foil barrier backing
MODEL: 601T
- 45° aluminum lattice with Fiberglass Back Plenum
MODEL: 645F-T
- $1/2'' \times 1/2'' \times 1''$ Lattice
- $1'' \times 1'' \times 1''$ Lattice
- 2" ADC compliant round collar with bead for ease of installation
- 1x1 T-Bar ($10'' \times 10''$ duct)
- 1x2 T-Bar ($10'' \times 22''$ duct)
- 2x4 T-Bar ($22'' \times 46''$ duct)

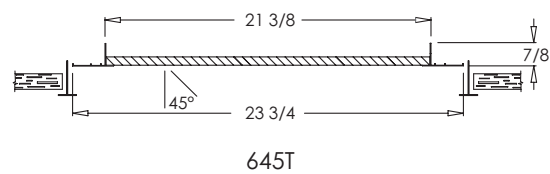
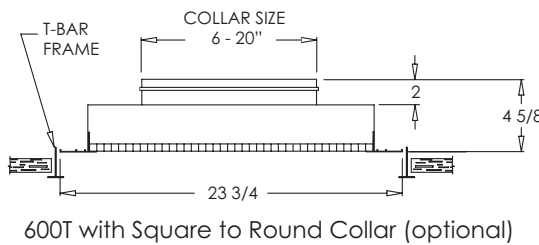
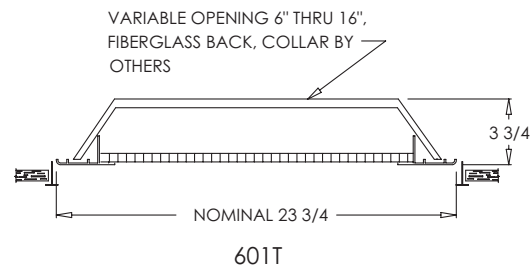
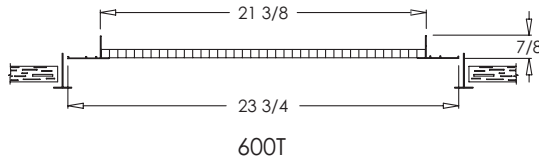

Performance Data: 600T Series

Neck Size	Core Eff. Area (ft ²)	Neck Velocity (FPM) Velocity Pressure	300	400	500	600	700	800	900	1000
			0.018	0.032	0.048	0.070	0.092	0.120	0.140	0.160
10×22	1.277	CFM	383	511	638	766	894	1021	1149	1277
		NC	<20	<20	<20	<20	<20	20	20-25	25-30
22×22	2.889	CFM	867	1156	1445	1733	2022	2311	2600	2889
		NC	<20	<20	<20	<20	<20	20	20-25	25-30
22×46	6.114	CFM	1834	2446	3057	3668	4280	4891	5503	6114
		NC	<20	<20	<20	<20	<20	25	25-30	30

Performance Notes:

1 Additional performance data for sizes not listed is available at www.shoemakermfg.com

2 Data obtained from tests conducted in accordance with ANSI/ASHRAE standard 70-2006



Field Adjustable



High Capacity



MRI Compatible



Expedited Service

LATTICE T-BAR RETURN

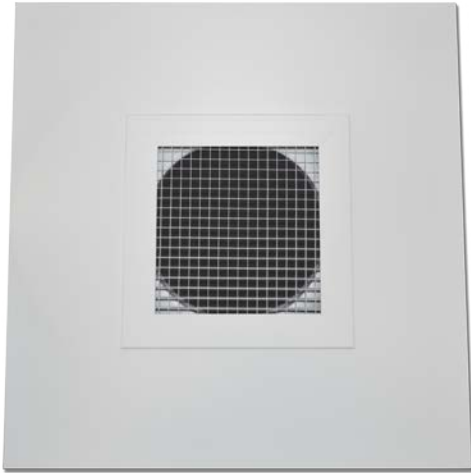

700-600 Series Aluminum Lattice Return Air Grille in T-Bar Panel

Standard Features:

- 1/2" × 1/2" × 1/2" Aluminum lattice return air grille
- Extruded aluminum frame with signature line marks fixed in a T-Bar panel
- 2" ADC compliant round collar with bead for ease of installation
- Rust resistant pre-coat with durable powder finish
- Soft White

Options:

- Recessed screwdriver operated Opposed Blade Damper
MODEL: 700-600-0
- 1/2" × 1/2" × 1/2" 45° aluminum lattice
MODEL: 700-645
- 1/2" × 1/2" × 1" Lattice
- 1" × 1" × 1" Lattice
- Square Collar
- TVB – Thermal Vapor Blanket
- NGD – Narrow ceiling grid dimples for 9/16" T-Rails, changes O.D. to 23 29/32"

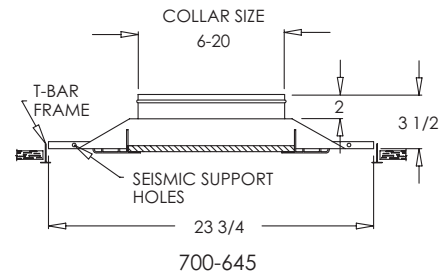
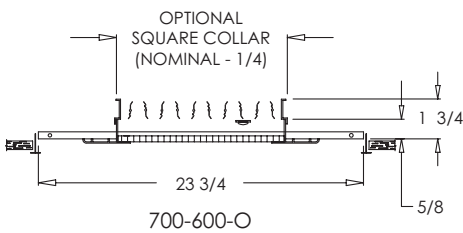
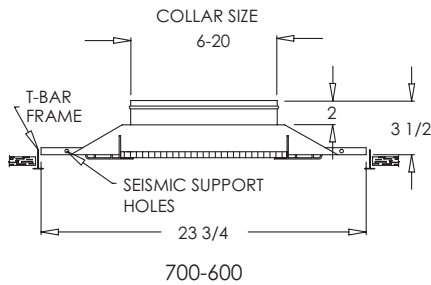

Performance Data: 700-600 Series

Neck Size	Core Eff. Area (ft ²)	Neck Velocity (FPM) Velocity Pressure	400	500	600	700	800	1000	1200
			0.032	0.048	0.070	0.092	0.120	0.140	0.160
6×6-6	0.156	CFM	63	78	94	109	125	156	188
		NC	<20	<20	<20	<20	20-25	25-30	25-30
8×8-8	0.291	CFM	116	145	174	203	232	291	349
		NC	<20	20-25	20-25	25-30	25-30	30	30
10×10-10	0.466	CFM	186	233	280	326	373	466	559
		NC	<20	25	25-30	25-30	30	30	35
12×12-12	0.683	CFM	273	342	410	478	546	683	820
		NC	<20	25	25-30	25-30	30	30	35
14×14-14	0.941	CFM	377	471	565	659	753	941	1130
		NC	<20	25	25-30	25-30	30	30	35
16×16-16	1.241	CFM	496	620	745	869	993	1241	1489
		NC	<20	25	25-30	25-30	30	30	35
18×18-18	1.582	CFM	633	791	949	1107	1265	1582	1898
		NC	<20	25	25-30	25-30	30	30	35
20×20-20	1.964	CFM	786	982	1178	1375	1571	1964	2357
		NC	<20	25	25-30	25-30	30	30	35

Performance Notes:

1 For square neck multiply CFM × 1.21

2 Additional performance data for sizes not listed is available at www.shoemakerfmfg.com

3 Data obtained from tests conducted in accordance with ANSI/ASHRAE standard 70-2006

FIXED BLADE T-BAR RETURN



935T Series Fixed 45° Steel Blade T-Bar Return Air Grille

Standard Features:

- Fixed 45° steel blade T-Bar lay-in return air grille
- Extruded aluminum frame with signature line marks
- Square collar designed for 22" × 22" duct
- Rust resistant pre-coat with durable powder finish
- Soft White

Options:

- Recessed screwdriver operated Opposed Blade Damper

MODEL: 935T-0

- Fixed 45° airfoil blades

MODEL: 905T

- 2" ADC compliant round collar with bead for ease of installation
- 1×2 T-Bar (10" × 22" duct)
- 2×4 T-Bar (22" × 46" duct)

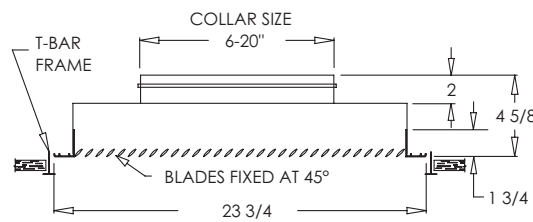
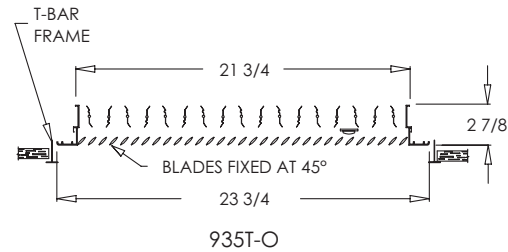
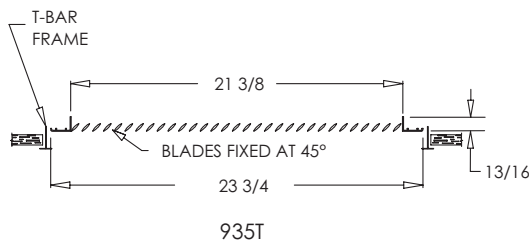

Performance Data: 935T Series

Neck Size	Core Eff. Area (ft ²)	Neck Velocity (FPM) Velocity Pressure	300	400	500	600	700	800	900	1000
			0.018	0.032	0.048	0.070	0.092	0.120	0.140	0.160
10×22	1.276	CFM	383	511	638	766	894	1021	1149	1276
		NC	<20	<20	<20	<20	<20	<20	20	25
22×22	2.910	CFM	873	1164	1455	1746	2037	2328	2619	2910
		NC	<20	<20	<20	<20	<20	<20	20	25
22×46	6.139	CFM	1842	2456	3069	3683	4297	4911	5525	6139
		NC	<20	<20	<20	20	20-25	25	25-30	30

Performance Notes:

1 Additional performance data for sizes not listed is available at www.shoemakermg.com

2 Data obtained from tests conducted in accordance with ANSI/ASHRAE standard 70-2006



Field Adjustable



High Capacity



MRI Compatible



Expedited Service

FIXED BLADE T-BAR RETURN



915T Series Fixed 45° Bar Blade T-Bar Return Air Grille

Standard Features:

- Fixed 45° extruded aluminum bar blade T-Bar lay-in return
- Extruded aluminum frame with signature line marks
- Design conceals duct from view
- Center margins mounted on backside of grille for a streamlined continuous look
- Square collar designed for 22" × 22" duct
- Rust resistant pre-coat with durable powder finish
- Soft White

Options:

- Recessed screwdriver operated Opposed Blade Damper
MODEL: 915T-0
- 2" ADC compliant round collar with bead for ease of installation
- 1×2 T-Bar (10" × 22" duct)
- 2×4 T-Bar (22" × 46" duct)

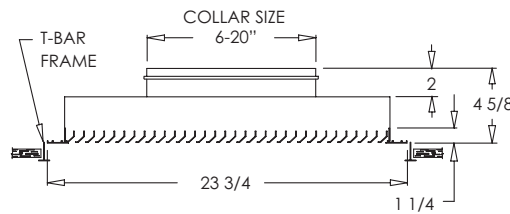
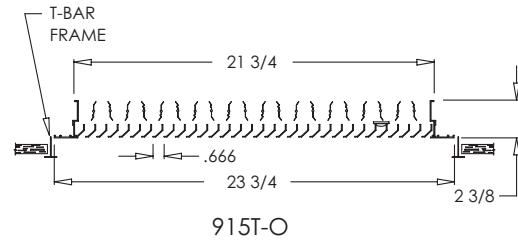
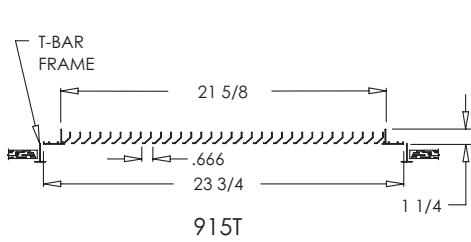

915T with Square to Round Collar (optional)

Performance Data: 915T Series

Neck Size	Core Eff. Area (ft ²)	Neck Velocity (FPM) Velocity Pressure	300	400	500	600	700	800	900	1000
			0.018	0.032	0.048	0.070	0.092	0.120	0.140	0.160
10×22	1.157	CFM	347	463	579	694	810	926	1041	1157
		NC	<20	<20	<20	<20	<20	<20	20	25
22×22	2.613	CFM	784	1045	1306	1568	1829	2090	2352	2613
		NC	<20	<20	<20	<20	<20	<20	20	25
22×46	5.530	CFM	1659	2212	2765	3318	3871	4424	4977	5530
		NC	<20	<20	<20	20	20-25	25	25-30	30

Performance Notes:

1 Additional performance data for sizes not listed is available at www.shoemakermg.com

2 Data obtained from tests conducted in accordance with ANSI/ASHRAE standard 70-2006

FIXED BLADE T-BAR RETURN



700-935 Fixed 45° Blade Return Air Grille in T-Bar Panel

Standard Features:

- Fixed 45° blade return air grille
- Extruded aluminum frame with signature line marks fixed in a T-Bar panel
- 2" ADC compliant round collar with bead for ease of installation
- Grille available in sizes 6×6 to 18×18
- Rust resistant pre-coat with durable powder finish
- Soft White

Options:

- Recessed screwdriver operated Opposed Blade Damper
MODEL: 700-935-0
- Square collar
- TVB – Thermal Vapor Blanket
- NGD – Narrow ceiling grid dimples for 9/16" T-Rails, changes O.D. to 23 29/32"

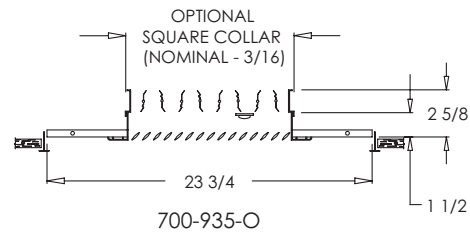
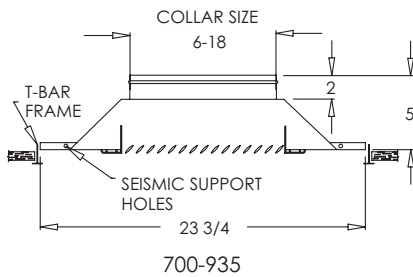

Performance Data: 700-935 Series

Neck Size	Core Eff. Area (ft ²)	Neck Velocity (FPM)	Velocity Pressure							
			400	500	600	700	800	1000	1200	
6×6-6	0.165	CFM	66	83	99	116	132	165	199	
		NC	<20	<20	20-25	25-30	30-35	35	35	
8×8-8	0.304	CFM	121	152	182	213	243	304	364	
		NC	<20	<20	20-25	30	35	35-40	40	
10×10-10	0.483	CFM	193	242	290	338	387	483	580	
		NC	20-25	25-30	30	30-35	35-40	40	40-45	
12×12-12	0.705	CFM	282	352	423	493	564	705	846	
		NC	20-25	25-30	30-35	35	35-40	40-45	45	
14×14-14	0.968	CFM	387	484	581	677	774	968	1161	
		NC	20-25	30	30-35	35-40	40-45	40-45	>45	
16×16-16	1.272	CFM	509	636	763	891	1018	1272	1527	
		NC	20-25	30	30-35	35-40	40-45	40-45	>45	
18×18-18	1.618	CFM	647	809	971	1133	1295	1618	1942	
		NC	25	30-35	35-40	35-40	40-45	45	>45	

Performance Notes:

1 For square neck multiply CFM × 1.21

2 Additional performance data for sizes not listed is available at www.shoemakermfg.com

3 Data obtained from tests conducted in accordance with ANSI/ASHRAE standard 70-2006



Field Adjustable



High Capacity



MRI Compatible



Expedited Service

PERFORATED T-BAR FILTER GRILLE



105PFG Series Perforated Face T-Bar Filter Grille

Standard Features:

- Perforated hinged removable face
- 3/16" holes on 1/4" staggered centers
- Face set in an outer T-Bar filter grille frame
- Hand operated lever for easy filter access
- Square collar designed for 20" × 20" duct
- Holds up to a 2" filter (not included)
- Rust resistant pre-coat with durable powder finish
- Soft White

Options:

- Preformed, contour molded fiberglass back with a foil barrier backing, accepts 6"-16" collar (collar by others.) Fixed perforated face, not removable. Holds up to 1" filter.

MODEL: 106PFG

- 2" ADC compliant round collar with bead for ease of installation

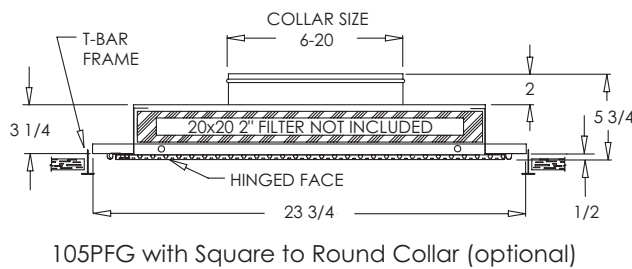
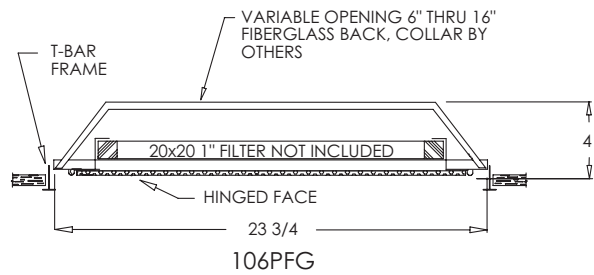
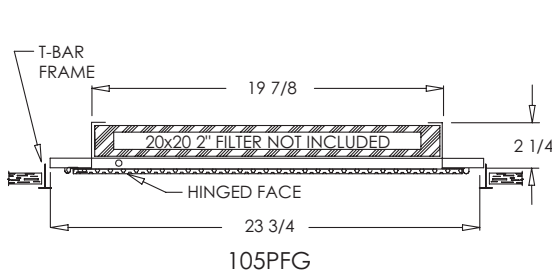

Performance Data: 105PFG Series

Neck Size	Core Eff. Area (ft ²)	Neck Velocity (FPM) Velocity Pressure	300	400	500	600	700	800	900	1000
			0.018	0.032	0.048	0.070	0.092	0.120	0.140	0.160
20×20	1.400	CFM	420	560	700	840	980	1120	1260	1400
		NC	<20	<20	<20	<20	<20	20-25	25	25-30

Performance Notes:

1 Additional performance data for sizes not listed is available at www.shoemakermg.com

2 Data obtained from tests conducted in accordance with ANSI/ASHRAE standard 70-2006

PERFORATED T-BAR FILTER GRILLE

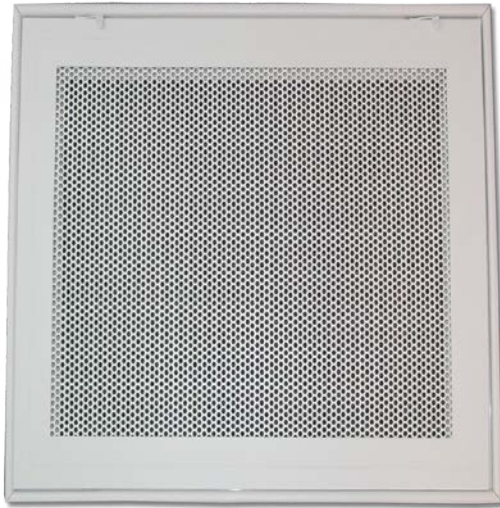

600PTFG Series Perforated Face T-Bar Filter Grille with Frame

Standard Features:

- 3/16" holes on 1/4" staggered centers
- Hinged removable extruded aluminum face frame with signature line marks
- Face set in an outer T-Bar filter grille frame
- Hand operated lever for easy filter access
- Square collar designed for 20" × 20" duct
- Holds up to a 2" filter (not included)
- Rust resistant pre-coat with durable powder finish
- Soft White

Options:

- Preformed, contour molded fiberglass back with a foil barrier backing, accepts 6"-16" collar (collar by others). Holds up to 1" filter.

MODEL: 601PTFG

- 2" ADC compliant round collar with bead for ease of installation
- 1×2 T-Bar (8" × 20" duct)
- 2×4 T-Bar (20" × 44" duct)

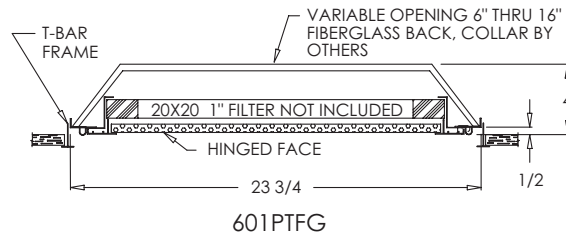
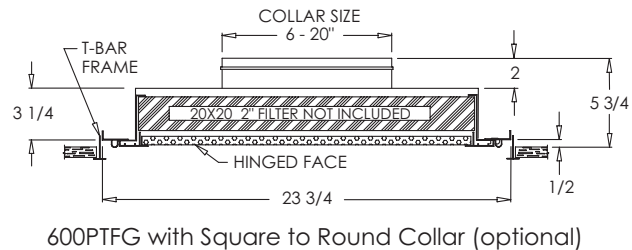
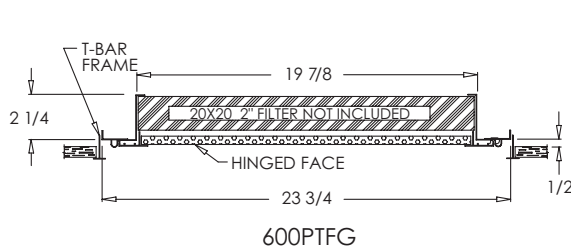

Performance Data: 600PTFG Series

Neck Size	Core Eff. Area (ft ²)	Neck Velocity (FPM) Velocity Pressure	300	400	500	600	700	800	900	1000
			CFM	161	215	269	323	377	431	484
8×20	0.538	NC	<20	<20	<20	<20	<20	20-25	25	25-30
		CFM	420	560	700	840	980	1120	1260	1400
20×20	1.400	NC	<20	<20	<20	<20	<20	20-25	25	25-30
		CFM	937	1249	1561	1873	2185	2498	2810	3122
20×44	3.122	NC	<20	<20	20	25	25	25-30	30	30-35

Performance Notes:

1 Additional performance data for sizes not listed is available at www.shoemakerfmfg.com

2 Data obtained from tests conducted in accordance with ANSI/ASHRAE standard 70-2006



Field Adjustable



High Capacity



MRI Compatible



Expedited Service

LATTICE T-BAR FILTER GRILLE

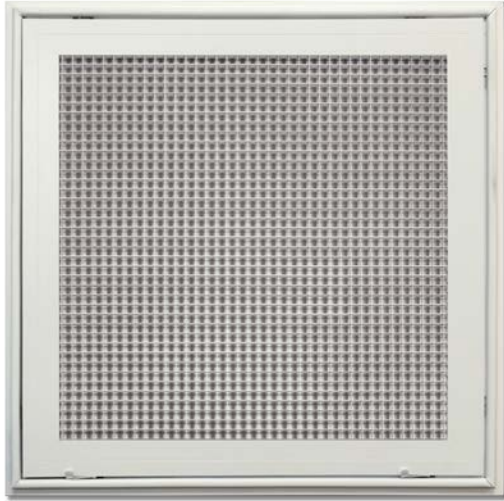

600TFG Series Aluminum Lattice T-Bar Filter Grille

Standard Features:

- 1/2" × 1/2" × 1/2" aluminum lattice
- Hinged removable extruded aluminum face frame with signature line marks
- Face set in an outer T-Bar filter grille frame
- Hand operated lever for easy filter access
- Square collar designed for 20" × 20" duct
- Holds up to a 2" filter (not included)
- Rust resistant pre-coat with durable powder finish
- Soft White

Options:

- 1/2" × 1/2" × 1/2" 45° aluminum lattice
MODEL: 645TFG
- Preformed, contour molded fiberglass back with a foil barrier backing, accepts 6"-16" collar (collar by others). Holds up to 1" filter.
MODEL: 601TFG
- 2" ADC compliant round collar with bead for ease of installation
- 1×2 T-Bar (8" × 20" duct)
- 2×4 T-Bar (20" × 44" duct)

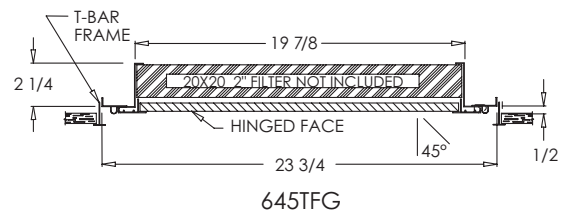
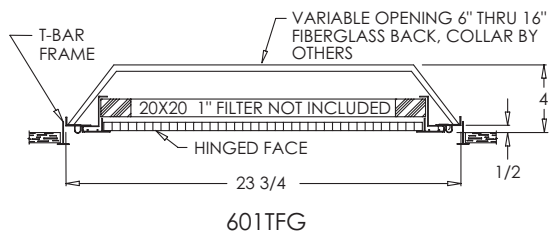
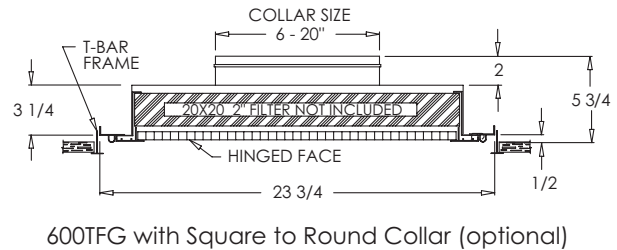
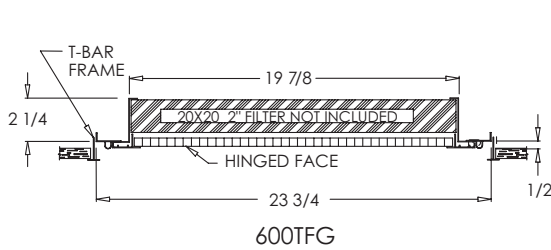

Performance Data: 600TFG Series

Neck Size	Core Eff. Area (ft ²)	Neck Velocity (FPM) Velocity Pressure	300	400	500	600	700	800	900	1000
			20×20	2.377	CFM	713	951	1188	1426	1664
		NC	<20	<20	<20	<20	<20	20	20-25	25-30
20×44	5.302	CFM	1590	2121	2651	3181	3711	4241	4771	5302
		NC	<20	<20	<20	<20	<20	25	25-30	30

Performance Notes:

1 Additional performance data for sizes not listed is available at www.shoemakerfmfg.com

2 Data obtained from tests conducted in accordance with ANSI/ASHRAE standard 70-2006

FIXED BLADE T-BAR FILTER GRILLE



935TFG Series Fixed 45° Steel Blade T-Bar Filter Grille

Standard Features:

- Fixed 45° steel blades
- Hinged removable extruded aluminum face frame with signature line marks
- Face set in an outer T-Bar filter grille frame
- Hand operated lever for easy filter access
- Square collar designed for 20" × 20" duct
- Holds up to a 2" filter (not included)
- Rust resistant pre-coat with durable powder finish
- Soft White

Options:

- Holds up to 4" filter (not included)
MODEL: 935TFG-4
- Preformed, contour molded fiberglass back with a foil barrier backing, accepts 6"-16" collar (collar by others). Holds up to 1" filter.
MODEL: 935F-TFG
- 2" ADC compliant round collar with bead for ease of installation
- 1×2 T-Bar (8" × 20" duct)
- 2×4 T-Bar (20" × 44" duct)

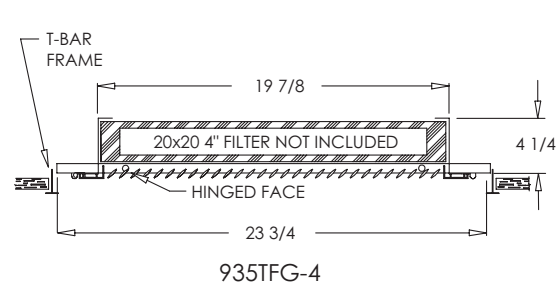
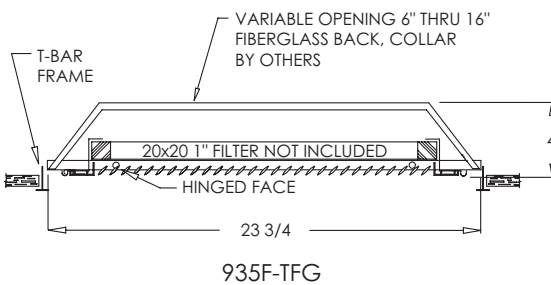
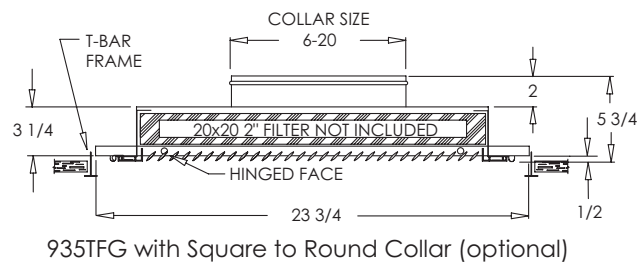
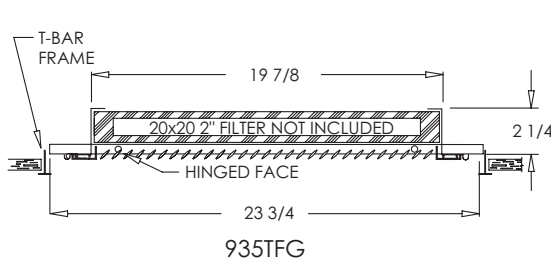

Performance Data: 935TFG Series

Neck Size	Core Eff. Area (ft ²)	Neck Velocity (FPM) Velocity Pressure	300	400	500	600	700	800	900	1000
			20×20	2.361	CFM	708	945	1181	1417	1653
		NC	<20	<20	<20	<20	<20	20	25-30	30
20×44	5.268	CFM	1580	2107	2634	3161	3687	4214	4741	5268
		NC	<20	<20	<20	<20	20	25	25-30	30

Performance Notes:

1 Additional performance data for sizes not listed is available at www.shoemakerfmfg.com

2 Data obtained from tests conducted in accordance with ANSI/ASHRAE standard 70-2006



Field Adjustable



High Capacity



MRI Compatible



Expedited Service

FIXED BLADE T-BAR FILTER GRILLE



905TFG Series Fixed 45° Airfoil Blade T-Bar Filter Grille

Standard Features:

- Fixed 45° aluminum airfoil blades
- Hinged removable extruded aluminum face frame with signature line marks
- Face set in an outer T-Bar filter grille frame
- Hand operated lever for easy filter access
- Square collar designed for 20" × 20" duct
- Holds up to a 2" filter (not included)
- Rust resistant pre-coat with durable powder finish
- Soft White

Options:

- Holds up to 4" filter
- **MODEL: 905TFG-4**
- 2" ADC compliant round collar with bead for ease of installation
- 1×2 T-Bar (8" × 20" duct)
- 2×4 T-Bar (22" × 46" duct)

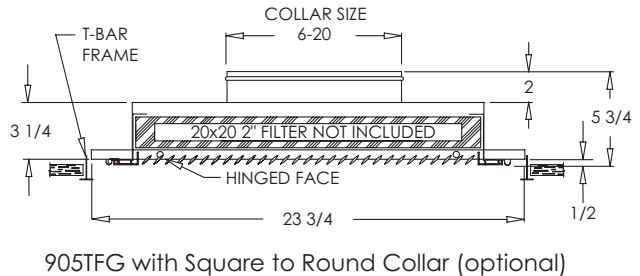
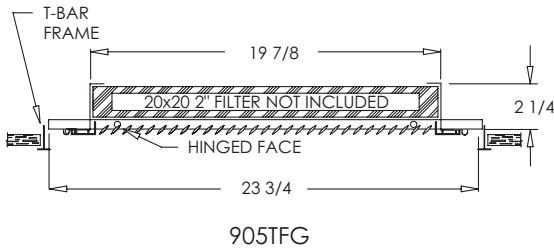

Performance Data: 905TFG Series

Neck Size	Core Eff. Area (ft ²)	Neck Velocity (FPM) Velocity Pressure	300	400	500	600	700	800	900	1000
			20×20	2.361	CFM	708	945	1181	1417	1653
	NC	<20	<20		<20	<20	<20	20	25-30	30
20×44	5.268	CFM	1580	2107	2634	3161	3687	4214	4741	5268
		NC	<20	<20	<20	<20	20	25	25-30	30

Performance Notes:

1 Additional performance data for sizes not listed is available at www.shoemakerfmg.com

2 Data obtained from tests conducted in accordance with ANSI/ASHRAE standard 70-2006

FIXED BLADE T-BAR FILTER GRILLE



915TFG Series Fixed 45° Bar Blade T-Bar Filter Grille

Standard Features:

- Fixed 45° extruded aluminum bar blades
- Hinged removable extruded aluminum face frame with signature line marks
- Face set in an outer T-Bar filter grille frame
- Hand operated lever for easy filter access
- Center margins are mounted on the backside of the grille for a streamlined continuous look
- Design conceals filter from view
- Square collar designed for 20" × 20" duct
- Holds up to a 2" filter (not included)
- Rust resistant pre-coat with durable powder finish
- Soft White

Options:

- 2" ADC compliant round collar with bead for ease of installation
- 1×2 T-Bar (8" × 20" duct)
- 2×4 T-Bar (20" × 44" duct)

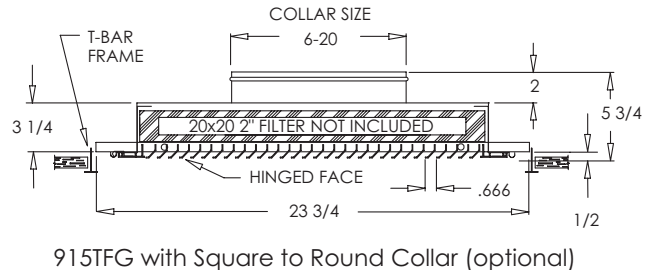
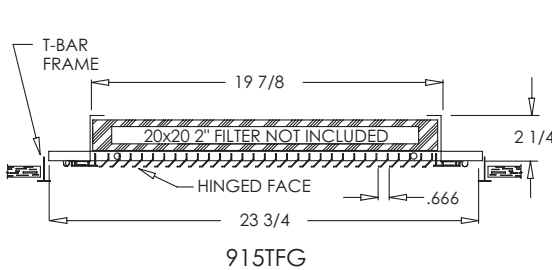

Performance Data: 915TFG Series

Neck Size	Core Eff. Area (ft ²)	Neck Velocity (FPM) Velocity Pressure	300	400	500	600	700	800	900	1000
			20×20	2.141	CFM	642	857	1071	1285	1499
		NC	<20	<20	<20	<20	<20	20	25-30	30
20×44	4.777	CFM	1433	1911	2388	2866	3344	3821	4299	4777
		NC	<20	<20	<20	<20	20	25	25-30	30

Performance Notes:

1 Additional performance data for sizes not listed is available at www.shoemakermfg.com

2 Data obtained from tests conducted in accordance with ANSI/ASHRAE standard 70-2006



Field Adjustable



High Capacity



MRI Compatible



Expedited Service

LOUVERED T-BAR FILTER GRILLE



105FG Stamped Face T-Bar Filter Grille

Standard Features:

- Stamped dual angular louvers with 1/2" spacing for strength and maximum free area
- Hinged removable face set in an outer T-Bar filter frame
- Hand operated lever for easy filter access
- Square collar designed for 20" × 20" duct
- Holds up to a 2" filter (not included)
- Rust resistant pre-coat with durable powder finish
- Soft White

Options:

- Preformed, contour molded fiberglass back with a foil barrier backing, accepts 6"-16" collars (collars by others.) Holds up to 1" filter.

MODEL: 106FG

- 2" ADC compliant round collar with bead for ease of installation

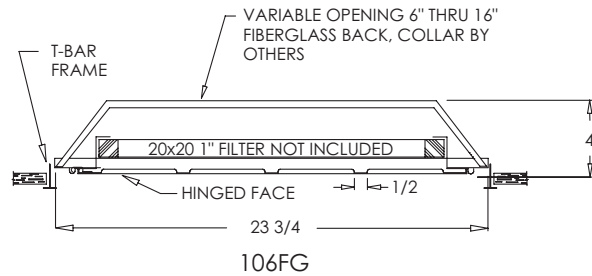
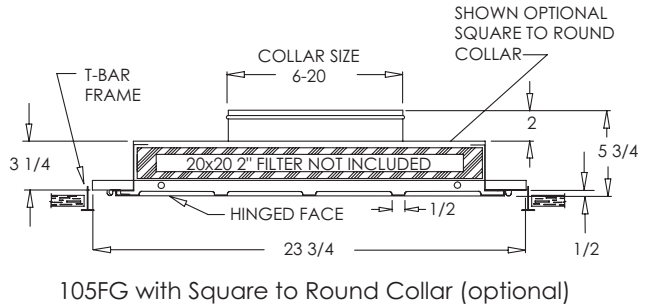
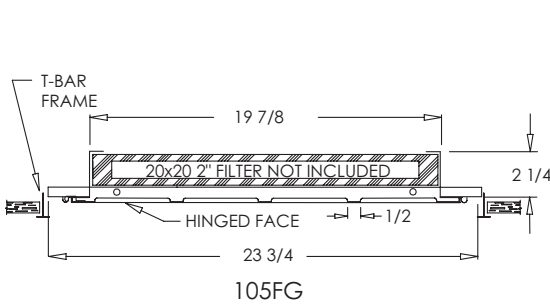

Performance Data: 105FG Series

Neck Size	Core Eff. Area (ft ²)	Neck Velocity (FPM) Velocity Pressure	300	400	500	600	700	800	900	1000	
			CFM	530	706	883	1060	1236	1413	1589	1766
20×20	1.766	NC	<20	<20	<20	<20	<20	<20	20-25	25	25-30

Performance Notes:

1 Additional performance data for sizes not listed is available at www.shoemakerfmfg.com

2 Data obtained from tests conducted in accordance with ANSI/ASHRAE standard 70-2006

T-BAR ACCESSORIES

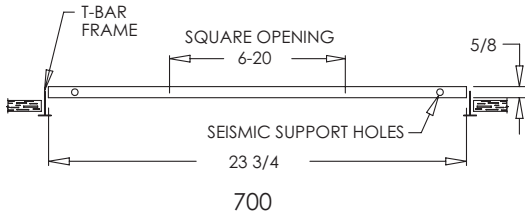
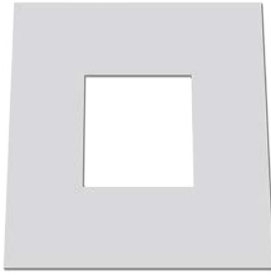

700 Series T-Bar Panel Only

Standard Features:

- 2 × 2 galvaneal steel T-Bar panel with seismic support holes
- Square hole in sizes 6" through 20"
- Rust resistant pre-coat with durable powder finish
- Soft White

Options:

- 1×1 Panel
- 1×2 Panel
- 2×4 Panel
- NGD – Narrow ceiling grid dimples for 9/16" T-Rails, changes O.D. to 23 29/32"

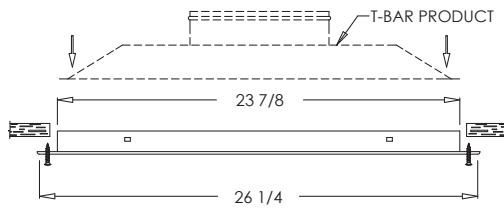

SMTB Series T-Bar to Surface Mount Conversion Frame

Standard Features:

- Converts T-Bar products to surface mount
- Sizes: 1×1, 1×2, 2×2, 2×4, odd and fractional sizes available
- Rust resistant pre-coat with durable powder finish
- Soft White

Options:

- SMTB-CM – concealed mounting holes in frame

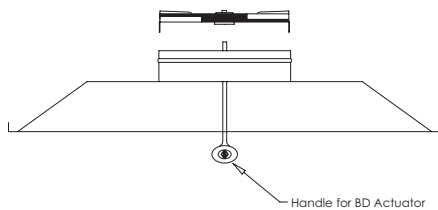

BD Series Bowtie Damper

Standard Features:

- Field installable bowtie damper
- Available 6, 8, 10, 12 and 14"
- Mill finish
- BD Handle, plastic adjustment tool



T-BAR ACCESSORIES

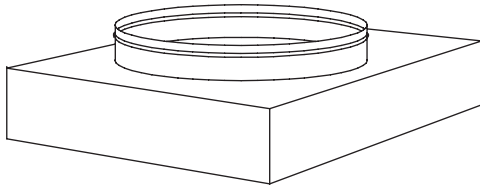

NLC Round Collar

Standard Features:

- 2" ADC compliant collar with roll formed retention bead
- Square to round transition for round duct installation
- Included standard on T-Bar products where noted
- Can be installed in field
- Mill finish

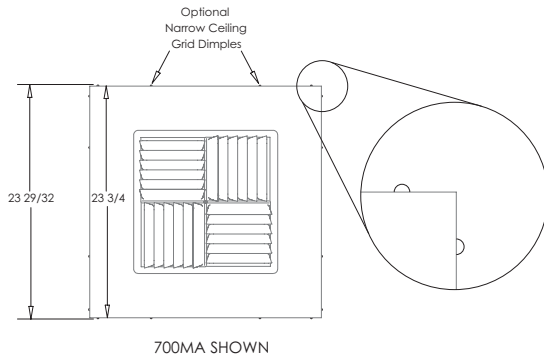

NGD Narrow Grid Dimples

Standard Features:

- For narrow grid T-Rail design (9/16")
- Dimples formed in frame change overall product dimension from 23 3/4" to 23 29/32" (3/32" undersized)
- Designed for simplified installation on narrow grid ceiling systems (less than 1" rails)

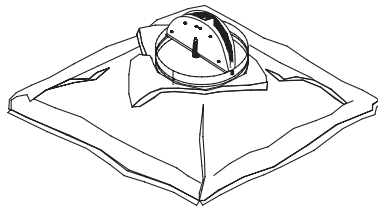

TTB

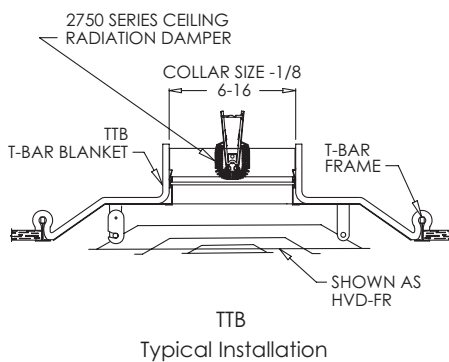

T-Bar Blankets

Thermal Vapor Blanket

- Formable 3/4 in. thick 2x2 foil faced insulation blanket (R8)
MODEL: TVB

Flexible Thermal Vapor Blanket

- Soft flexible 2 1/2 in. thick 2x2 foil faced insulation blanket (R8)
MODEL: BLKT

Thermal Blanket

- 28" x 28", 1/4 thickness, #6 density ceramic fiber with woven mesh screen and starter hole
MODEL: TTB

Fiberglass Back Plenum

- Preformed, contour molded fiberglass backing with a foil barrier backing (R4)
MODEL: FBP



#46

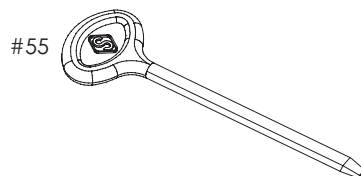

Miscellaneous T-Bar Accessories

- #46 – Soft White touch-up paint
- #55 – BD Handle, plastic adjustment tool















OVERVIEW

Shoemaker commercial grilles and diffusers are designed for surface mount applications. Our extensive product line includes everything from value-driven options to highly customized engineered solutions. Our product designs focus on quality and practicality. Standard features incorporated into our Commercial product line include:

- Nylon bushings on all adjustable blades, including opposed blade dampers, to prevent the annoying “metal on metal” rattling sound
- Countersunk mounting holes with color-matching Philips posi-drive screws for a clean, aesthetically pleasing appearance and to assist in a secure, centered installation.
- Rust resistant pre-coat with durable powder coat paint finish

Product Key

The product key located on the bottom of each page uses symbols to note options, features and services that are found repeatedly throughout this section of the catalog:

-  **STANDARD COLOR:** Rust resistant pre-coat with durable powder coat paint finish in Soft White or Driftwood Tan.
-  **DESIGNER COLOR:** Rust resistant pre-coat with durable powder coat paint finish available in custom colors. See appendix or website for list of available colors. Additional charges apply.
-  **ALUMINUM PAINT:** Closely replicates a cleaned aluminum finish with the added benefits of our powder coat painting process. Additional charges apply.
-  **SATIN ANODIZED:** Constructed with satin anodized aluminum extrusions best described as a polished aluminum look. Factory cleaned prior to shipping. Additional charges apply.
-  **MILL FINISH:** Raw (no finish), factory cleaned.
-  **GALVANIZED FINISH:** Steel with protective zinc coating. Factory cleaned. Closely matches finish of galvanized spiral pipe.
-  **FIELD ADJUSTABLE:** Product has standard features and/or options to allow for adjustment in the field.
-  **HIGH CAPACITY:** Product is designed to deliver high volumes of air.
-  **MRI COMPATIBLE:** Constructed with MRI compatible materials (standard product or available option).
-  **MULTI-FAMILY PRODUCT:** Available with lever-operated Opposed Blade Damper or commonly used in multi-family housing project designs (standard product or available option).
-  **EXPEDITED SERVICES PROGRAM:** Available with Expedited Service Program, products manufactured faster than standard lead times. Additional charges apply. See website for program details.
-  **EXTENDED LEADTIME:** Product not available in our standard lead time. Contact customer service for lead time quote.

CURVED BLADE CEILING DIFFUSERS



CB10 – One way deflection with adjustable blades.



CB20-B – Two way deflection with adjustable blades parallel to the shortest dimension given.



CB20-D – Two way deflection, adjustable horizontal and vertical blades. Used primarily for corner applications.



CB30 – Three way deflection, adjustable horizontal and vertical blades.



CB20-F – Two way deflection, adjustable horizontal and vertical blades. Used primarily for corner applications.



CB40 – Four way deflection, adjustable horizontal and vertical blades.

CB Series Adjustable Aluminum Curved Blade Diffuser

Standard Features:

- Adjustable aluminum curved blades
- Nylon bushings on adjustable blades prevent metal on metal rattle
- Extruded aluminum surface mount frame with signature line marks
- Eighteen air patterns
- Countersunk mounting holes for flush appearance with color matching Philips posi-drive screws
- Rust resistant pre-coat with durable powder finish
- Soft White

Options:

- Recessed screwdriver operated Opposed Blade Damper
MODEL: CB-0
- Steel construction in three or four way air pattern with lever operated multi-shutter damper. See website for more details.
MODEL: SCB
- 2" ADC compliant round collar with bead for ease of installation – available in square sizes only
- T-20 Tamper Proof Screws



Performance Data: CB10 & CB20 Series

Duct Size	Core Eff. Area (ft ²)	Neck Velocity (FPM)		400		500		600		700		800		1000						
		CFM	NC	0.038	0.108	0.155	0.220	0.285	0.438											
6x6	0.176	CFM	70	88	105	123	141	176												
		NC	<20	<20	<20	<20	20	20												
		2-Way Throw (ft.)	5	6	9	5	7	11	7	9	13	9	11	16	10	13	19	12	16	21
		1-Way Throw (ft.)	4	6	11	6	8	13	9	11	16	10	13	19	13	16	22	15	19	25
8x8	0.326	CFM	130	163	195	228	261	326												
		NC	<20	<20	<20	<20	20	25												
		2-Way Throw (ft.)	5	7	12	7	9	14	9	12	17	11	14	21	14	17	24	16	21	28
		1-Way Throw (ft.)	6	8	14	9	11	16	11	14	20	13	16	24	16	20	28	19	24	32
10x10	0.521	CFM	209	261	313	365	417	521												
		NC	<20	<20	20	20-25	25	25-30												
		2-Way Throw (ft.)	7	9	15	9	12	18	12	15	23	15	18	27	18	23	31	21	27	36
		1-Way Throw (ft.)	8	11	18	11	14	21	14	18	26	17	21	31	20	26	37	24	31	42
12x12	0.763	CFM	305	382	458	534	611	763												
		NC	<20	<20	20	20-25	25	25-30												
		2-Way Throw (ft.)	9	12	20	12	16	23	16	20	29	18	23	35	22	29	41	27	35	47
		1-Way Throw (ft.)	11	14	23	13	18	27	18	23	34	21	27	41	26	34	48	32	41	54
14x14	1.051	CFM	420	525	630	736	841	1051												
		NC	<20	<20	20	25	25-30	30												
		2-Way Throw (ft.)	10	13	22	13	18	27	17	22	33	21	27	40	25	33	46	31	40	53
		1-Way Throw (ft.)	12	16	26	16	21	31	21	26	39	24	31	46	30	39	54	35	46	62
16x16	1.384	CFM	554	692	830	969	1107	1384												
		NC	<20	<20	20	25	25-30	30												
		2-Way Throw (ft.)	11	15	25	15	20	30	20	25	38	23	30	45	29	38	53	35	45	60
		1-Way Throw (ft.)	13	18	29	18	24	35	23	29	44	27	35	53	34	44	62	41	53	70
18x18	1.763	CFM	705	882	1058	1234	1411	1763												
		NC	<20	<20	20	25	25-30	30												
		2-Way Throw (ft.)	13	17	29	17	23	34	23	29	43	26	34	52	33	43	60	40	52	69
		1-Way Throw (ft.)	14	20	34	21	27	40	28	34	50	31	40	60	40	50	70	47	60	80
20x20	2.189	CFM	875	1094	1313	1532	1751	2189												
		NC	<20	<20	20	25	25-30	30												
		2-Way Throw (ft.)	14	20	33	20	26	39	27	33	49	30	39	59	39	49	68	46	59	78
		1-Way Throw (ft.)	16	23	38	25	31	46	30	38	57	36	46	68	45	57	80	53	68	91
24x24	3.177	CFM	1271	1588	1906	2224	2541	3177												
		NC	<20	<20	25	25-30	30	30-35												
		2-Way Throw (ft.)	16	22	37	24	30	45	29	37	56	35	45	67	44	56	78	52	67	89
		1-Way Throw (ft.)	18	26	43	28	35	52	34	43	65	40	52	78	51	65	91	61	78	104

Performance Notes:

- Additional performance data for sizes not listed is available at www.shoemakerfmg.com
- Throw values are measured in feet for terminal velocities of 150/100/50 FPM
- Throw data is based on supply air and room air both at isothermal conditions
- Effective core areas listed in chart are defined as the measurement of space between the blades actually being utilized by the air
- Data obtained from tests conducted in accordance with ANSI/ASHRAE standard 70-2006

Air Patterns:

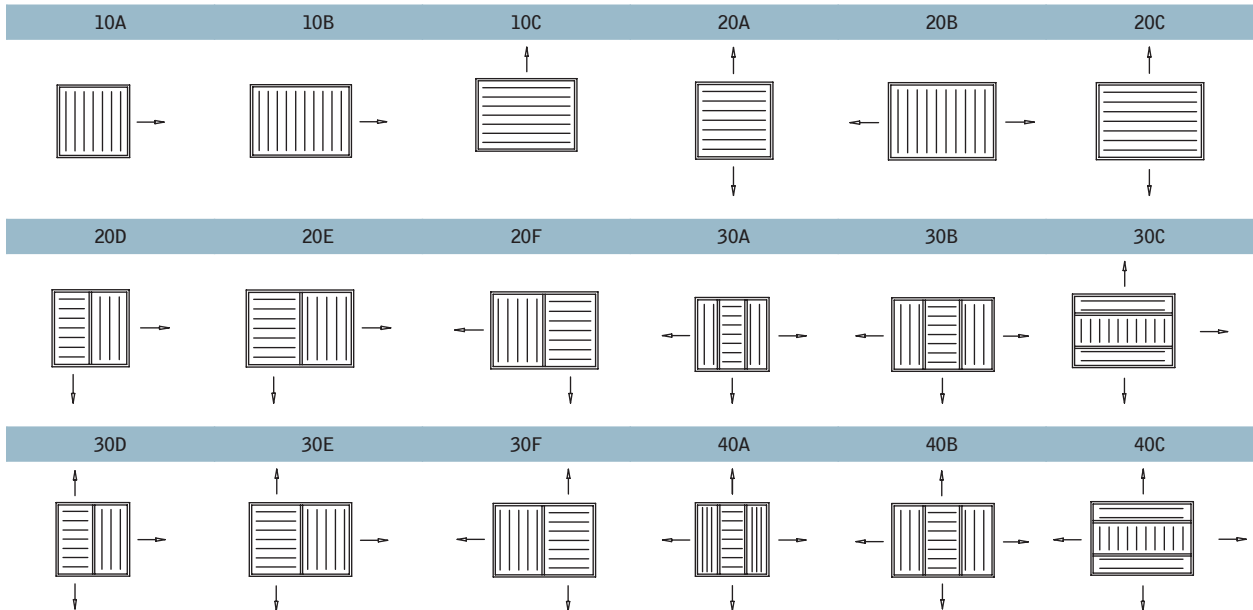

Performance Data: CB30 & CB40 Series

Duct Size	Core Eff. Area (ft ²)	Neck Velocity (FPM)		400			500			600			700			800			1000		
		Total Pressure	CFM	0.038	0.108	0.155	0.220	0.285	0.438												
6x6	0.149	CFM	59			74			89			104			119			149			
		NC	<20			<20			<20			<20			20			20			
		4-Way Throw (ft.)	3	4	7	4	5	8	6	7	10	6	8	12	8	10	14	9	12	16	
		3-Way Throw (ft.)	4	5	8	5	6	9	6	8	12	7	9	14	9	12	16	11	14	18	
		8x8	0.289	CFM	116			144			173			202			231			289	
NC	<20			<20			<20			<20			20			25					
4-Way Throw (ft.)	4			5	9	5	7	10	7	9	13	8	10	15	10	13	18	12	15	20	
3-Way Throw (ft.)	4			6	10	6	8	12	8	10	15	10	12	18	12	15	21	14	18	24	
10x10	0.475			CFM	190			237			285			332			380			475	
		NC	<20			<20			20			20-25			25			25-30			
		4-Way Throw (ft.)	6	7	11	7	9	13	9	11	17	10	13	20	14	17	23	15	20	26	
		3-Way Throw (ft.)	6	8	13	8	10	16	10	13	19	13	16	23	15	19	27	18	23	31	
		12x12	0.707	CFM	283			353			424			495			565			707	
NC	<20			<20			20			20-25			25			25-30					
4-Way Throw (ft.)	7			9	14	9	12	17	11	14	22	14	17	26	17	22	30	20	26	34	
3-Way Throw (ft.)	8			10	17	10	13	20	13	17	25	16	20	30	19	25	35	23	30	40	
14x14	0.984			CFM	394			492			591			689			787			984	
		NC	<20			<20			20			25			25-30			30			
		4-Way Throw (ft.)	8	10	16	10	13	20	12	16	24	16	20	29	19	24	34	22	29	39	
		3-Way Throw (ft.)	9	12	19	11	15	23	15	19	29	18	23	34	22	29	40	26	34	45	
		16x16	1.308	CFM	523			654			785			916			1046			1308	
NC	<20			<20			20			25			25-30			30					
4-Way Throw (ft.)	8			11	19	11	15	22	15	19	28	17	22	33	21	28	39	25	33	44	
3-Way Throw (ft.)	10			13	22	13	17	26	17	22	32	20	26	39	24	32	45	30	39	52	
18x18	1.677			CFM	671			839			1006			1174			1342			1677	
		NC	<20			<20			20			25			25-30			30			
		4-Way Throw (ft.)	10	13	21	13	17	25	16	21	32	20	25	38	24	32	44	29	38	51	
		3-Way Throw (ft.)	11	15	25	15	20	30	20	25	37	23	30	44	28	37	52	34	44	59	
		20x20	2.093	CFM	837			1046			1256			1465			1674			2093	
NC	<20			<20			20			25			25-30			30					
4-Way Throw (ft.)	11			15	24	14	19	29	19	24	36	22	29	43	27	36	50	33	43	58	
3-Way Throw (ft.)	13			17	28	17	23	34	22	28	42	26	34	50	33	42	59	39	50	67	
24x24	3.061			CFM	1224			1531			1837			2143			2449			3061	
		NC	<20			20			25			25-30			30			30-35			
		4-Way Throw (ft.)	13	17	27	17	22	33	21	27	41	25	33	49	32	41	57	38	49	65	
		3-Way Throw (ft.)	14	19	32	20	26	38	26	32	48	29	38	57	38	48	67	44	57	76	

Performance Notes:

- 1 Additional performance data for sizes not listed is available at www.shoemakerfmg.com
- 2 Throw values are measured in feet for terminal velocities of 150/100/50 FPM
- 3 Throw data is based on supply air and room air both at isothermal conditions
- 4 Effective core areas listed in chart are defined as the measurement of space between the blades actually being utilized by the air
- 5 Data obtained from tests conducted in accordance with ANSI/ASHRAE standard 70-2006

CURVED BLADE CEILING DIFFUSERS

CB10/CB10-0

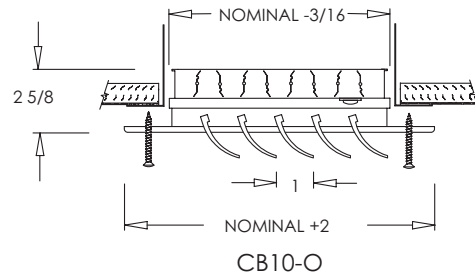
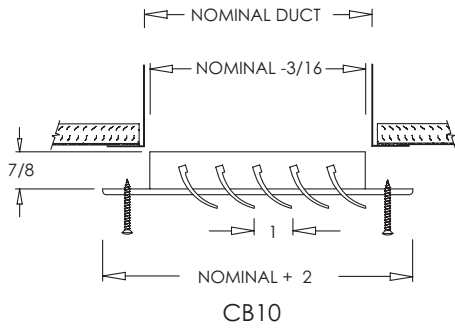

CB20/CB20-0

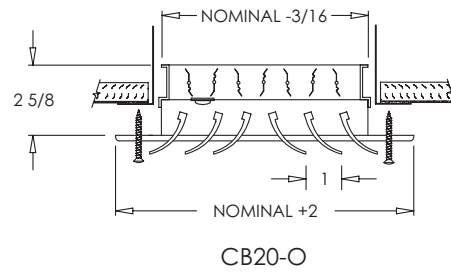
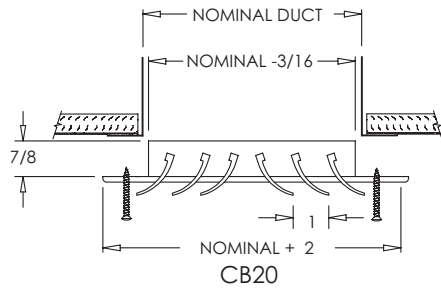

CB30/CB30-0

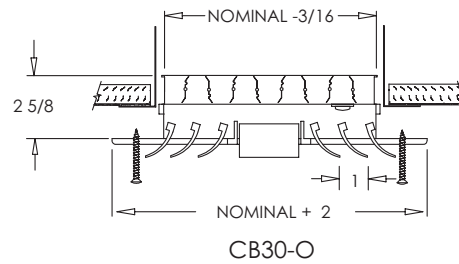
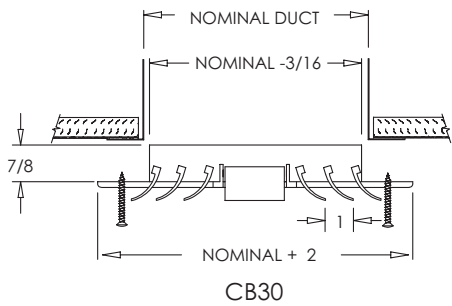

CB40/CB40-0

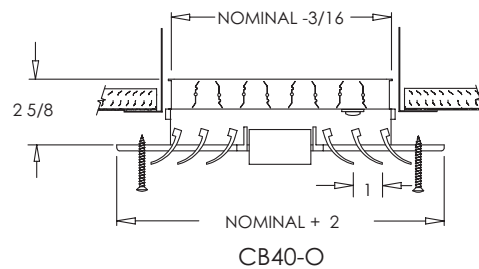
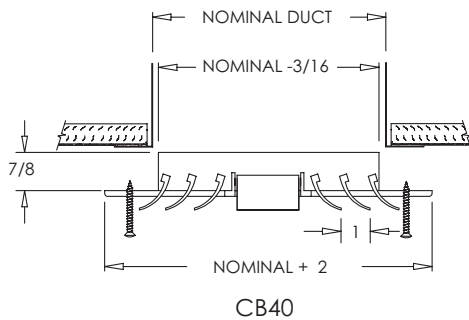

Field Adjustable



High Capacity



MRI Compatible



Multi-Family



Expedited Service



Extended Leadtime

MODULAR CORE CEILING DIFFUSERS

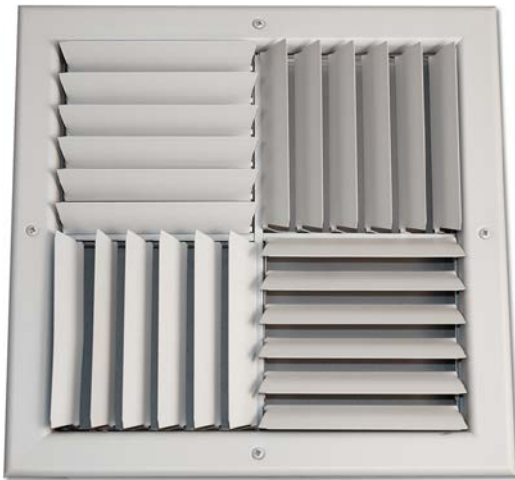

MA

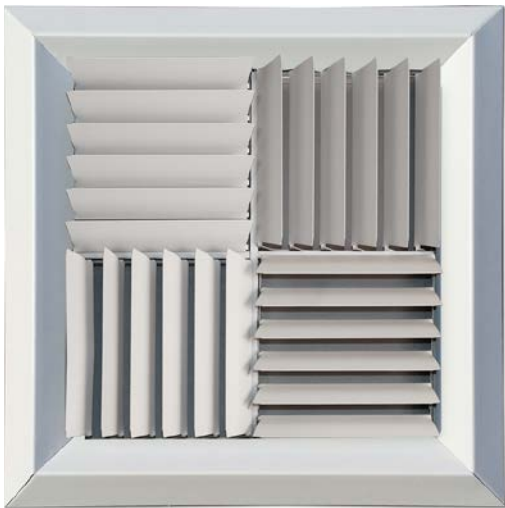

MA-DCF

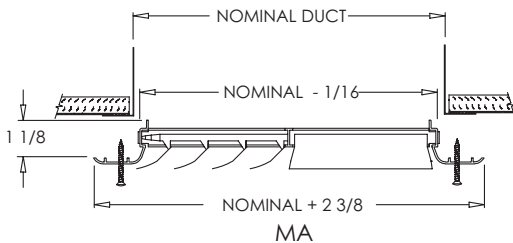

MA

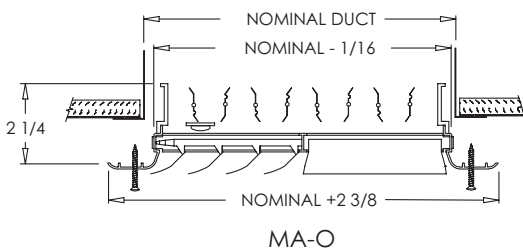

MA-O

MA Series Modular Core Diffuser

Standard Features:

- Adjustable modular cores with fixed curved blades
- Maintains horizontal airflow pattern
- Extruded aluminum surface mount frame with signature line marks
- Square collar
- Countersunk mounting holes for flush appearance with color matching Philips posi-drive screws
- Rust resistant pre-coat with durable powder finish
- Soft White

Options:

- Modular cores with individually adjustable curved blades
MODEL: MCB
- Deep Ceiling Frame (steel) with concealed mounting holes
MODEL: MA-DCF
- Concealed mounting holes
MODEL: MA-CM
- Recessed screwdriver operated Opposed Blade Damper
MODEL: MA-O / MA-O-DCF
- 2" ADC compliant round collar with bead for ease of installation – available in square sizes only
- T-20 Tamper Proof Screws

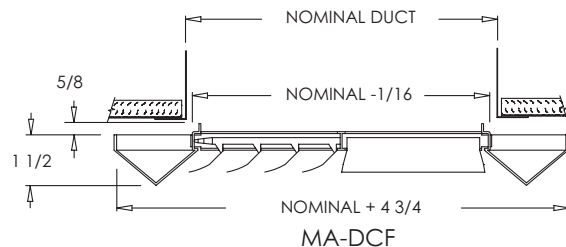

MA-DCF

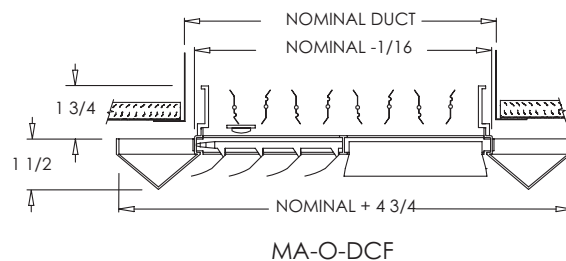

MA-O-DCF



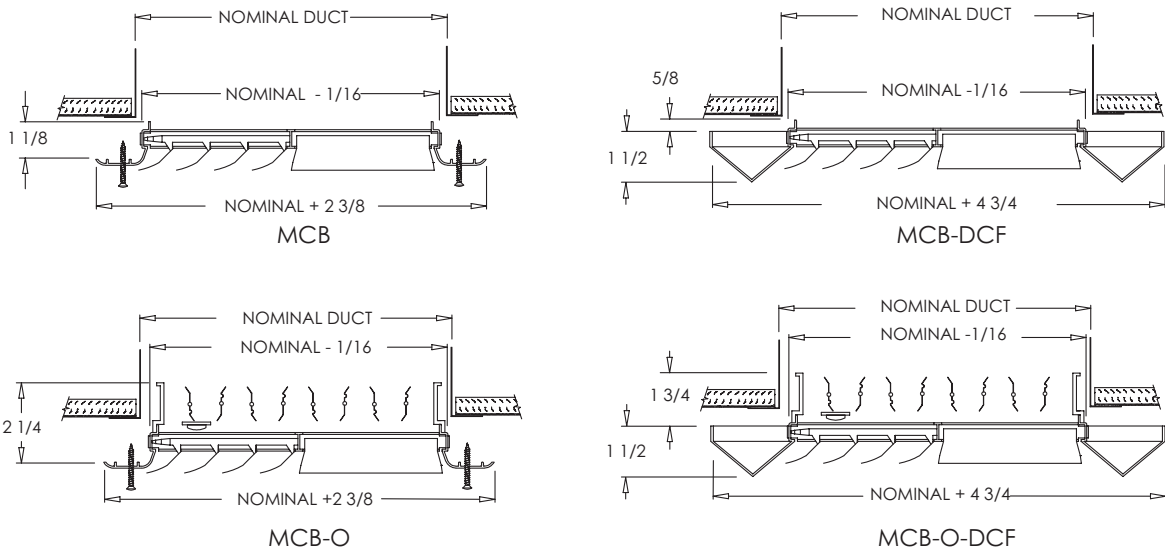

Performance Data: MA Series

Duct Size	Core Eff. Area (ft ²)	Neck Velocity (FPM)	400		500		600		700		800		1000					
			Total Pressure		0.038		0.108		0.155		0.220		0.285		0.438			
6×6	0.150	CFM	60		75		90		105		120		150					
		NC	<20		20		25		25-30		30		35					
		Throw(ft.)	3	5	9	4	6	12	5	7	14	6	8	16	7	9	17	9
8×8	0.296	CFM	118		148		178		207		237		296					
		NC	<20		20		25		25-30		30		35					
		Throw(ft.)	6	8	13	7	9	15	7	10	18	8	11	20	9	12	21	10
10×10	0.492	CFM	197		246		295		344		393		492					
		NC	20		20		25		25-30		30		40					
		Throw(ft.)	8	10	15	8	10	19	9	12	21	10	13	22	11	14	24	12
12×12	0.736	CFM	294		368		442		515		589		736					
		NC	20		25		25-30		30		35		40					
		Throw(ft.)	9	11	19	10	13	21	12	15	23	13	16	25	14	17	27	15
14×14	1.030	CFM	412		515		618		721		824		1030					
		NC	20		25		25-30		30		35		40					
		Throw(ft.)	10	12	21	11	14	24	14	17	27	14	18	28	15	19	29	17
16×16	1.373	CFM	549		686		824		961		1098		1373					
		NC	<20		25		30		35		35		45					
		Throw(ft.)	11	13	25	12	16	28	15	18	30	15	19	31	17	21	33	18
18×18	1.765	CFM	706		883		1059		1236		1412		1765					
		NC	<20		25		30		35		40		45					
		Throw(ft.)	12	15	27	14	18	32	16	20	33	17	22	36	19	24	38	20
20×20	2.206	CFM	883		1103		1324		1544		1765		2206					
		NC	<20		25		30		35		40		45					
		Throw(ft.)	14	18	28	17	21	33	18	23	35	20	25	39	21	26	41	22
24×24	3.236	CFM	1295		1618		1942		2265		2589		3236					
		NC	<20		25		30		40		45		45-50					
		Throw(ft.)	15	19	33	20	25	39	21	28	46	22	29	47	24	32	48	26

Performance Notes:

- Additional performance data for sizes not listed is available at www.shoemakerfmg.com
- Throw values are measured in feet for terminal velocities of 150/100/50 FPM
- Throw data is based on supply air and room air both at isothermal conditions
- Effective core areas listed in chart are defined as the measurement of space between the blades actually being utilized by the air
- Data obtained from tests conducted in accordance with ANSI/ASHRAE standard 70-2006

Throw factors for core configuration: (Throw × Throw Factor)		1.00 throw factor		1.20 throw factor		1.40 throw factor		2.00 throw factor
---	--	-------------------	--	-------------------	--	-------------------	--	-------------------

SPIRAL DIFFUSERS



USR52



USR34

USR Series Universal Spiral Diffuser

Standard Features:

- Galvanized steel construction
- Nylon bushings on adj. blades prevent metal on metal rattle
- High quality foam gasketing for tight seal with duct
- Product sizes available to fit spiral pipe sizes 6" – 48"
- Galvanized Finish

MODEL: USR52

- Single deflection adjustable blade diffuser
- Blades are parallel to the shortest dimension
- Allows for 2-way airflow adjustment

MODEL: USR34

- Double deflection adjustable blade diffuser
- Front blades are parallel to shortest dimension
- Back blades are parallel to longest dimension
- Allows for 4-way airflow adjustment

Options:

- Adjustable airfoil blades
MODEL: A-USR34, A-USR52
- Perforated face register
MODEL: USR-PERF
- Recessed screwdriver operated Opposed Blade Damper
MODEL: USR34-O, USR52-O
- Half-length screwdriver operated Scoop Extractor
MODEL: USR34-SC, USR52-SC
- Full-length screwdriver operated Scoop Extractor (24" max length scoop)
MODEL: USR34-FS, USR52-FS



USR34 / USR52 Series Spiral Pipe Sizing Chart

Diffuser Width	Diffuser Length								
	10"	12"	14"	16"	18"	20"	24"	30"	36"
3"	6" – 24"	6" – 24"	6" – 24"	6" – 24"	6" – 24"	6" – 24"	6" – 24"	6" – 24"	6" – 24"
4"	10" – 24"	10" – 24"	10" – 24"	10" – 24"	10" – 24"	10" – 24"	10" – 24"	10" – 24"	10" – 24"
6"	12" – 24"	12" – 24"	12" – 24"	12" – 24"	12" – 24"	12" – 24"	12" – 24"	12" – 24"	12" – 24"
8"	n/a	n/a	20" – 36"	20" – 36"	20" – 36"	20" – 36"	20" – 36"	20" – 36"	20" – 36"
10"	n/a	n/a	n/a	n/a	30" – 48"	30" – 48"	30" – 48"	30" – 48"	30" – 48"
12"	n/a	n/a	n/a	n/a	42" – 48"	42" – 48"	42" – 48"	42" – 48"	42" – 48"

* Chart denotes spiral pipe diameter compatible with product size (Example: USR34-10×3 fits pipe sizes 6" through 24" diameter)

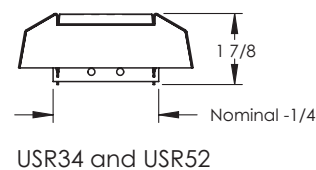
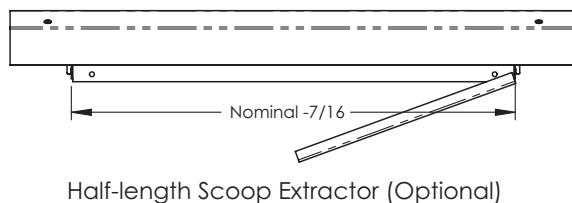

Performance Data: USR34 Series

Duct Size	Core Eff. Area (ft ²)	Neck Velocity (FPM)		Velocity Pressure																							
		300	400	500	600	700	800	1000	1200	1400	0.004	0.008	0.013	0.018	0.025	0.033	0.051	0.074	0.100								
10x3	0.139	CFM	42	55	69	83	97	111	139	166	194																
		NC	<20	<20	<20	20	20-25	25	30	35	40																
		Throw(ft.)	3	4	5	5	6	7	6	7	8.5	6	7.5	8.5	8	9	12.5	9	10	13	10	11.5	15	12	13	21	15
12x3	0.168	CFM	50	67	84	101	117	134	168	201	235																
		NC	<20	<20	<20	20	20-25	25	30	35	40																
		Throw(ft.)	4	4.5	5.5	5	6	7.5	7	8	9	7	8	10	9	10	14	10	11	14.5	11	13	20	13	14.5	23	17
10x4	0.191	CFM	57	76	95	115	134	153	191	229	267																
		NC	<20	<20	<20	20	25	30	35	40	45																
		Throw(ft.)	5	5.5	6.5	6	7	9	8	9	11	9	10	14	11	12	16	12	13.5	18	14	16	24	16	18	28	19
12x4	0.231	CFM	69	92	116	139	162	185	231	277	323																
		NC	<20	<20	<20	20	25	30	35	40	45																
		Throw(ft.)	5	5.5	6.5	6	7	9	8	9	11	9	10	14	11	12	16	12	13.5	18	14	16	24	16	18	28	19
16x4	0.311	CFM	93	125	156	187	218	249	311	374	436																
		NC	<20	<20	<20	20	25	30	35	40	45																
		Throw(ft.)	5	6.5	7.5	7	8	10	10	11	13	11	12	16	13	14.5	20	14	16	22	16	19	29	19	22	34	22
12x6	0.362	CFM	109	145	181	217	254	290	362	435	507																
		NC	<20	<20	<20	20	25	30	35	40	45-50																
		Throw(ft.)	6	7	8	8	9	11	10	11.5	14	12	13	18	14	16	21	16	18	24	18	21	32	22	26	38	25
14x6	0.425	CFM	128	170	213	255	298	340	425	510	595																
		NC	<20	<20	<20	20	25	30	35	40	45-50																
		Throw(ft.)	6	7.5	9	9	10	12	11	11.5	14.5	12	13.5	19	14	16	22	17	19	25	19	22	33	22	26	39	25
16x6	0.472	CFM	142	189	236	283	330	377	472	566	660																
		NC	<20	<20	<20	20	25	30	35	40	45-50																
		Throw	7	8	10	9	10	12	11	12.5	16	13	14.5	20	15	17	23	17	20	26	19	22	34	23	27	40	26
18x6	0.551	CFM	165	220	276	331	386	441	551	661	772																
		NC	<20	<20	<20	20	25	30	35	40	45-50																
		Throw(ft.)	7	8	10	9	10	12	11	12.5	16	13	14.5	20	15	17	23	17	20	27	20	23	34	23	27	41	26
14x8	0.580	CFM	174	232	290	348	406	464	580	695	811																
		NC	<20	<20	<20	20	25	30	35	40	45-50																
		Throw(ft.)	7	8	10	9	10.5	12.5	12	13	17	13	15	21	16	18	24	18	21	28	20	23	36	24	28	43	28
20x6	0.614	CFM	184	246	307	368	430	491	614	737	860																
		NC	<20	<20	<20	20	25	30	35	40	45-50																
		Throw	7	8.5	10.5	9	10.5	13	12	13.5	17	14	15.5	21	16	18	25	18	21	28	20	24	37	25	29	44	29
30x6	0.929	CFM	279	372	464	557	650	743	929	1115	1300																
		NC	<20	<20	20	25	30	30-35	35-40	40-45	>55																
		Throw	10	11	13.5	13	15	19	16	19	23	18	21	28	20	24	35	23	28	38	27	33	50	34	41	59	38

Performance Notes:

- Performance data calculated with blades set at 0°
- Additional performance data for sizes not listed is available at www.shoemakermfg.com
- Throw values are measured in feet for terminal velocities of 150/100/50 FPM
- Throw data is based on supply air and room air both at isothermal conditions
- Effective core areas listed in chart are defined as the measurement of space between the blades actually being utilized by the air
- Data obtained from tests conducted in accordance with ANSI/ASHRAE standard 70-2006

Performance Data: USR52 Series

Duct Size	Core Eff. Area (ft ²)	Neck Velocity (FPM) Velocity Pressure	300	400	500	600	700	800	1000	1200	1400																
			0.004	0.008	0.013	0.018	0.025	0.033	0.051	0.074	0.100																
10x3	0.150	CFM	45	60	75	90	105	120	150	180	210																
		NC	<20	<20	<20	20	25	30	35	40	40																
		Throw(ft.)	3	4	5	5	6	7	6	7	8.5	9	7.5	8.5	8	9	12.5	9	10	13	11	11.5	19	12	13	21	15
12x3	0.181	CFM	54	72	91	109	127	145	181	217	254																
		NC	<20	<20	<20	20	20-25	25	30	35	40																
		Throw(ft.)	4	4.5	5.5	5	6	7.5	7	8	9	7	8	10	9	10	14	10	11	14.5	12	13	20	13	15	23	17
10x4	0.210	CFM	63	84	105	126	147	168	210	252	293																
		NC	<20	<20	<20	20	25	30	35	40	45																
		Throw (ft.)	4	5	6	5	6.5	8.5	8	8.5	9.5	7	8.5	11	10	11	15	11	12	16	13	14	20	14	16	24	18
12x4	0.254	CFM	76	101	127	152	178	203	254	304	355																
		NC	<20	<20	<20	20	25	30	35	40	45																
		Throw (ft.)	5	5.5	6.5	6	7	9	8	9	11	9	10	14	11	12	16	12	13.5	18	14	16	24	16	18	28	19
16x4	0.342	CFM	103	137	171	205	239	273	342	410	479																
		NC	<20	<20	<20	20	25	30	35	40	45																
		Throw(ft.)	5	6.5	7.5	7	8	10	10	11	13	11	12	16	13	14.5	20	14	16	22	17	19	29	19	22	34	22
12x6	0.399	CFM	120	159	199	239	279	319	399	478	558																
		NC	<20	<20	<20	20	25	30	35	40	45-50																
		Throw (ft.)	6	7	9	9	10	12	10	11.5	14.5	12	13.5	18	14	16	22	16	18	24	19	22	32	22	26	38	25
14x6	0.468	CFM	140	187	234	281	328	374	468	561	655																
		NC	<20	<20	<20	20	25	30	35	40	45-50																
		Throw (ft.)	7	8	10	10	11	13	11	13	16	14	16	21	15	17	23	18	20	27	20	23	35	24	28	42	27
16x6	0.537	CFM	161	215	269	322	376	430	537	645	752																
		NC	<20	<20	<20	20	25	30	35	40	45-50																
		Throw (ft.)	8	8.5	11	10	11.5	13.5	12	13.5	17	14	16	22	16	18	25	18	20	28	21	24	36	25	29	45	28
18x6	0.606	CFM	182	243	303	364	424	485	606	728	849																
		NC	<20	<20	<20	20	25	30	35	40	45-50																
		Throw(ft.)	8	8.5	11	10	11.5	14.5	12	14.5	18	15	17	23	18	20	27	19	22	30	22	26	38	26	31	47	29
14x8	0.638	CFM	191	255	319	383	447	510	638	766	893																
		NC	<20	<20	<20	20	25	30	35	40	45-50																
		Throw (ft.)	8	9	11.5	11	13	16	4	16	19	16	18	24	19	21	28	20	23	31	23	27	39	27	32	48	30
20x6	0.676	CFM	203	270	338	405	473	540	676	811	946																
		NC	<20	<20	<20	20	25	30	35	40-45	45-50																
		Throw	8	9	11.5	11	13	16	4	16	19	16	18	24	19	21	28	20	23	31	23	27	39	27	32	48	30
30x6	1.022	CFM	307	409	511	613	715	817	1022	1226	1430																
		NC	<20	<20	20	25	30	30-35	35-40	40-45	>50																
		Throw	9	11	13.5	13	15	19	17	19	23	19	21	28	21	24	35	24	28	38	27	33	50	33	41	59	38

Performance Notes:

1 Performance data calculated with blades set at 0°
 2 Additional performance data for sizes not listed is available at www.shoemakerfmg.com

3 Throw values are measured in feet for terminal velocities of 150/100/50 FPM
 4 Throw data is based on supply air and room air both at isothermal conditions

5 Effective core areas listed in chart are defined as the measurement of space between the blades actually being utilized by the air
 6 Data obtained from tests conducted in accordance with ANSI/ASHRAE standard 70-2006

SPIRAL DIFFUSERS



SD Series Transition Box Spiral Pipe Diffuser

Standard Features:

- Transition box mount spiral pipe diffuser
- Nylon bushings on adj. blades prevent metal on metal rattle
- Curved saddle with gasket provides airtight fit to spiral pipe
- Product sizes available to fit spiral pipe diameters 8"–48." Spiral pipe diameter must be 4" larger than width of diffuser.
- Galvanized finish

MODEL: SD52

- Single deflection diffuser
- Blades are parallel to the shortest dimension
- Allows for 2-way airflow adjustment

MODEL: SD34

- Double deflection diffuser
- Front blades are parallel to shortest dimension
- Back blades are parallel to longest dimension
- Allows for 4-way airflow adjustment

Options:

- Linear bar face
MODEL: SD-LSW
- Perforated face
MODEL: SD-600P
- Lattice face
MODEL: SD-600
- Recessed screwdriver operated Opposed Blade Damper
MODEL: SD34-0, SD52-0
- Half-length screwdriver operated Scoop Extractor
MODEL: SD34-SC, SD52-SC
- Full-length screwdriver operated Scoop Extractor
MODEL: SD34-FS, SD52-FS

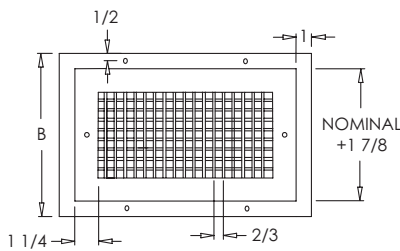

SD34

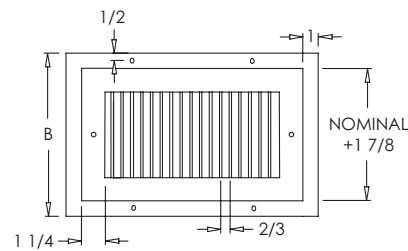

SD52

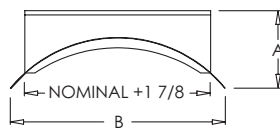

SD34/SD52

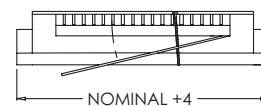

Full Scoop (optional)



Field Adjustable



High Capacity



MRI Compatible



Multi-Family



Expedited Service



Extended Leadtime

SD34 and SD52 Series Dimensions

Diffuser Width	Dimension*	Pipe Diameter											
		8"	10"	12"	14"	16"	18"	20"	22"	24"	26"	28"	
4"	A	5	4 7/8	4 7/8	4 3/4	4 3/4	4 5/8	4 1/2	4 1/2	4 1/2	4 1/2	4 1/2	
	B	7 1/8	7 3/8	7 1/2	7 5/8	7 3/4	7 7/8	7 7/8	7 7/8	7 7/8	7 7/8	7 7/8	
6"	A	n/a	5	5	4 7/8	4 3/4	4 3/4	4 5/8	4 5/8	4 1/2	4 1/2	4 1/2	
	B	n/a	9	9 1/4	9 1/2	9 5/8	9 3/4	9 7/8	9 7/8	9 7/8	9 7/8	9 7/8	
8"	A	n/a	n/a	5 1/8	5	4 7/8	4 3/4	4 3/4	4 5/8	4 5/8	4 5/8	4 1/2	
	B	n/a	n/a	10 7/8	11 1/4	11 3/8	11 5/8	11 3/4	11 7/8	11 7/8	11 7/8	11 7/8	
10"	A	n/a	n/a	n/a	5	5	4 7/8	4 7/8	4 3/4	4 3/4	4 5/8	4 5/8	
	B	n/a	n/a	n/a	13	13 1/4	13 3/8	13 1/2	13 5/8	13 5/8	13 7/8	13 7/8	
12"	A	n/a	n/a	n/a	n/a	5 1/8	5	4 7/8	4 7/8	4 7/8	4 3/4	4 5/8	
	B	n/a	n/a	n/a	n/a	14 7/8	15 1/8	15 3/8	15 1/2	15 1/2	15 5/8	15 7/8	

Diffuser Width	Dimension*	Pipe Diameter											
		30"	32"	34"	36"	38"	40"	42"	44"	46"	48"		
4"	A	4 1/2	4 1/2	4 1/2	4 1/2	4 1/2	4 3/8	4 3/8	4 3/8	4 3/8	4 3/8	4 3/8	
	B	7 7/8	7 7/8	7 7/8	7 7/8	7 7/8	8	8	8	8	8	8	
6"	A	4 1/2	4 1/2	4 1/2	4 1/2	4 1/2	4 1/2	4 3/8	4 3/8	4 3/8	4 3/8	4 3/8	
	B	9 7/8	9 7/8	9 7/8	9 7/8	9 7/8	9 7/8	10	10	10	10	10	
8"	A	4 1/2	4 1/2	4 1/2	4 1/2	4 1/2	4 1/2	4 1/2	4 3/8	4 3/8	4 3/8	4 3/8	
	B	11 7/8	11 7/8	11 7/8	11 7/8	11 7/8	11 7/8	11 7/8	12	12	12	12	
10"	A	4 5/8	4 1/2	4 1/2	4 1/2	4 1/2	4 1/2	4 1/2	4 1/2	4 3/8	4 3/8	4 3/8	
	B	13 7/8	13 7/8	13 7/8	13 7/8	13 7/8	13 7/8	13 7/8	13 7/8	14	14	14	
12"	A	4 5/8	4 5/8	4 5/8	4 1/2	4 1/2	4 1/2	4 1/2	4 1/2	4 1/2	4 1/2	4 1/2	
	B	15 7/8	15 7/8	15 7/8	15 7/8	15 7/8	15 7/8	15 7/8	15 7/8	15 7/8	15 7/8	15 7/8	

* A/B dimensions defined in product drawings are dependent on size of spiral pipe product is designed.

Performance Data: SD34 Series

Duct Size	Core Eff. Area (ft ²)	Neck Velocity (FPM)	Total Pressure																								
			0.004	0.008	0.013	0.018	0.025	0.033	0.051	0.074	0.100																
14x4	0.271	CFM	81 108 136 163 190 217 271 325 380																								
		NC	<20 <20 <20 20 25 30 35 40 45																								
		Throw(ft.)	5	6.5	7.5	7	8	10	10	11	13	11	12	16	13	14.5	20	14	16	22	16	19	29	19	22	34	22
10x6	0.299	CFM	90 120 150 180 210 240 299 359 419																								
		NC	<20 <20 <20 20 25 30 35 40 45																								
		Throw(ft.)	5	6.5	7.5	7	8	10	10	11	13	11	12	16	13	14.5	20	14	16	22	16	19	29	19	22	34	22
12x6	0.362	CFM	109 145 181 217 254 290 362 435 507																								
		NC	<20 <20 <20 20 25 30 35 40 45-50																								
		Throw(ft.)	6	7	8	8	9	11	10	11.5	14	12	13	18	14	16	21	16	18	24	18	21	32	22	26	38	25
14x6	0.425	CFM	128 170 213 255 298 340 425 510 595																								
		NC	<20 <20 <20 20 25 30 35 40 45-50																								
		Throw(ft.)	6	7.5	9	9	10	12	11	11.5	14.5	12	13.5	19	14	16	22	17	19	25	19	22	33	22	26	39	25
16x6	0.488	CFM	146 195 244 293 342 391 488 586 684																								
		NC	<20 <20 <20 20 25 30 35 40 45-50																								
		Throw (ft.)	7	8	10	9	10	12	11	12.5	16	13	14.5	20	15	17	23	17	20	26	19	22	34	23	27	40	26
14x8	0.580	CFM	174 232 290 348 406 464 580 695 811																								
		NC	<20 <20 <20 20 25 30 35 40 45-50																								
		Throw(ft.)	7	8	10	9	10.5	12.5	12	13	17	13	15	21	16	18	24	18	21	28	20	23	36	24	28	43	28
16x8	0.665	CFM	200 266 333 399 466 532 665 798 931																								
		NC	<20 <20 <20 20 25 30 35-40 40-45 >50																								
		Throw (ft.)	8	8.5	10.5	10	11	13.5	13	14.5	18	14	16	22	17	19	26	18	21	29	21	25	38	25	30	45	30
18x8	0.751	CFM	225 300 376 451 526 601 751 901 1051																								
		NC	<20 <20 <20 20 25 30 35-40 40-45 >50																								
		Throw (ft.)	8	9	11	10	11.5	14.5	14	16	19	15	17	23	17	20	27	19	22	30	22	26	40	27	32	48	31
20x10	1.059	CFM	318 424 530 636 742 848 1059 1271 1483																								
		NC	<20 <20 20 25 30 30-35 35-40 40-45 >50																								
		Throw(ft.)	10	11.5	14.5	14	16	20	17	20	24	19	22	30	22	26	37	25	30	40	29	35	53	35	42	62	40
20x12	1.277	CFM	383 511 638 766 894 1021 1277 1532 1787																								
		NC	<20 <20 20 25 30 30-35 35-40 40-45 >55																								
		Throw (ft.)	11	12.5	15.5	16	18	22	19	22	25	21	24	34	24	29	40	28	33	45	32	38	58	39	46	69	46
24x12	1.545	CFM	463 618 772 927 1081 1236 1545 1854 2163																								
		NC	<20 <20 20 25 30 30-35 35-40 40-45 >55																								
		Throw(ft.)	13	14.5	18	17	19	23	20	23	28	23	27	37	27	32	43	30	36	48	35	42	64	40	50	76	48
30x10	1.602	CFM	481 641 801 961 1122 1282 1602 1923 2243																								
		NC	<20 <20 20 25 30 30-35 35-40 40-45 >55																								
		Throw (ft.)	13	15	19	18	20	24	21	24	29	24	28	38	28	33	44	31	38	49	36	43	65	41	51	78	49

Performance Notes:

1 Performance data calculated with blades set at 0°
 2 Additional performance data for sizes not listed is available at www.shoemakermf.com

3 Throw values are measured in feet for terminal velocities of 150/100/50 FPM
 4 Throw data is based on supply air and room air both at isothermal conditions

5 Effective core areas listed in chart are defined as the measurement of space between the blades actually being utilized by the air
 6 Data obtained from tests conducted in accordance with ANSI/ASHRAE standard 70-2006

Performance Data: SD52 Series

Duct Size	Core Eff. Area (ft ²)	Neck Velocity (FPM)		300		400		500		600		700		800		1000		1200		1400										
		Total Pressure		0.004	0.008	0.013	0.018	0.025	0.033	0.051	0.074	0.100																		
14x4	0.298	CFM		89	119	149	179	208	238	298	357	417																		
		NC		<20	<20	<20	20	25	30	35	40	45																		
		Throw (ft.)		5	6	7	6	7.5	9.5	9	10	12	10	11	15	12	14	19	13	15	20	16	18	27	18	21	33	21	24	38
10x6	0.329	CFM		99	132	165	198	231	264	329	395	461																		
		NC		<20	<20	<20	20	25	30	35	40	45																		
		Throw (ft.)		5	6.5	7.5	7	8	10	10	11	13	11	12	16	13	14.5	20	14	16	22	17	19	29	19	22	34	22	26	40
12x6	0.399	CFM		120	159	199	239	279	319	399	478	558																		
		NC		<20	<20	<20	20	25	30	35	40	45-50																		
		Throw (ft.)		6	7	9	9	10	12	10	11.5	14.5	12	13.5	18	14	16	22	16	18	24	19	22	32	22	26	38	25	30	44
14x6	0.468	CFM		140	187	234	281	328	374	468	561	655																		
		NC		<20	<20	<20	20	25	30	35	40	45-50																		
		Throw (ft.)		7	8	10	10	11	13	11	13	16	14	16	21	15	17	23	18	20	27	20	23	35	24	28	42	27	33	49
16x6	0.537	CFM		161	215	269	322	376	430	537	645	752																		
		NC		<20	<20	<20	20	25	30	35	40	45-50																		
		Throw (ft.)		8	8.5	11	10	11.5	13.5	12	13.5	17	14	16	22	16	18	25	18	20	28	21	24	36	25	29	45	28	34	52
14x8	0.638	CFM		191	255	319	383	447	510	638	766	893																		
		NC		<20	<20	<20	20	25	30	35	40	45-50																		
		Throw (ft.)		8	9	11.5	11	13	16	14	16	19	16	18	24	19	21	28	20	23	31	23	27	39	27	32	48	30	37	55
16x8	0.732	CFM		220	293	366	439	513	586	732	879	1025																		
		NC		<20	<20	<20	20	25	30	35-40	40-50	>50																		
		Throw (ft.)		9	10	12.5	12	14	17	15	17	20	17	19	25	20	23	30	22	25	33	25	29	41	29	35	51	32	40	58
20x10	1.167	CFM		350	467	583	700	817	934	1167	1400	1634																		
		NC		<20	<20	20	25	30	30-35	35-40	40-45	>50																		
		Throw (ft.)		10	11.5	14.5	14	16	20	18	20	24	19	22	30	23	26	37	25	30	40	29	35	53	34	42	62	40	49	73
20x12	1.413	CFM		424	565	706	848	989	1130	1413	1695	1978																		
		NC		<20	<20	20	25	30	30-35	35-40	40-45	>55																		
		Throw (ft.)		11	12.5	16	15	18	22	19	22	25	21	24	34	25	29	40	27	33	45	31	38	58	37	46	69	45	56	80
24x12	1.702	CFM		511	681	851	1021	1191	1362	1702	2042	2383																		
		NC		<20	<20	20	25	30	30-35	35-40	40-45	>50																		
		Throw (ft.)		13	15	18	17	19	23	20	23	28	23	27	37	27	32	43	29	36	48	34	42	64	41	50	76	48	59	89
30x10	1.765	CFM		529	706	882	1059	1235	1412	1765	2118	2471																		
		NC		<20	<20	20	25	30	30-35	35-40	40-45	>55																		
		Throw (ft.)		13	15	19	18	20	24	21	24	29	24	28	38	28	33	44	30	38	49	35	43	65	42	51	78	49	60	91

Performance Notes:

- 1 Performance data calculated with blades set at 0°
- 2 Additional performance data for sizes not listed is available at www.shoemakerfmg.com
- 3 Throw values are measured in feet for terminal velocities of 150/100/50 FPM
- 4 Throw data is based on supply air and room air both at isothermal conditions
- 5 Effective core areas listed in chart are defined as the measurement of space between the blades actually being utilized by the air
- 6 Data obtained from tests conducted in accordance with ANSI/ASHRAE standard 70-2006

SPIRAL DIFFUSERS



RS Series Radius Spiral Pipe Diffuser

Standard Features:

- Radius mount spiral pipe diffuser
- Nylon bushings on adj. blades prevent metal on metal rattle
- One piece curved frame with gasket fits flush to spiral pipe
- Product sizes available to fit spiral pipe diameter 8" – 48."
 - Spiral pipe diameter must be 4" larger than width of diffuser.
- Galvanized finish

MODEL: RS52

- Single deflection diffuser with adjustable blades
- Blades are parallel to the shortest dimension
- Allows for 2-way airflow

MODEL: RS34

- Double deflection diffuser with adjustable blades
- Front blades are parallel to shortest dimension
- Back blades are parallel to longest dimension
- Allows for 4-way airflow

Options:

- Perforated face diffuser

MODEL: RS-PERF

- Recessed screwdriver operated Opposed Blade Damper

MODEL: RS34-0, RS52-0

- Half-length screwdriver operated Scoop Extractor

MODEL: RS34-SC, RS52-SC

- Full-length screwdriver operated Scoop Extractor

MODEL: RS34-FS, RS52-FS

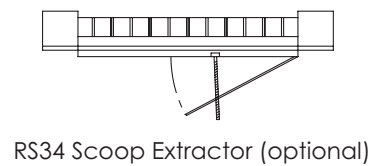
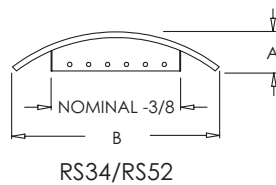
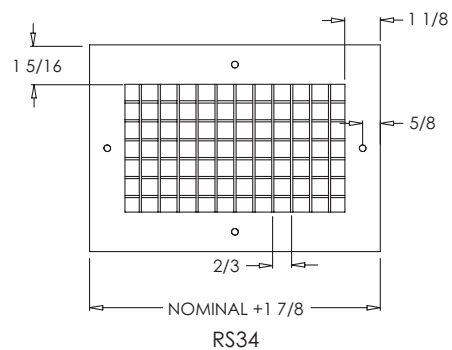
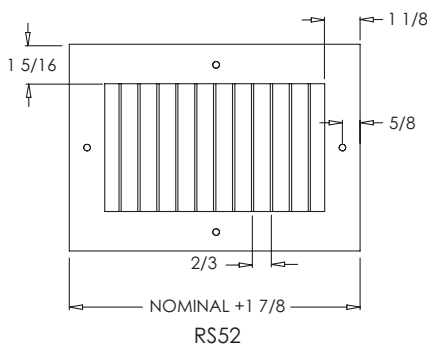

RS34 Series Dimensions

Diffuser Width	Dimension*	Pipe Diameter										
		8"	10"	12"	14"	16"	18"	20"	22"	24"	26"	28"
4"	A	2 1/8	2	2	2	2	2	1 7/8	1 7/8	1 7/8	1 7/8	1 7/8
	B	5 3/8	5 1/2	5 5/8	5 3/4	5 3/4	5 3/4	5 3/4	5 3/4	5 7/8	5 7/8	5 7/8
6"	A	n/a	2 1/2	2	2 1/4	2 1/4	2 1/8	2 1/8	2 1/8	2	2	2
	B	n/a	7	7 3/8	7 1/2	7 1/2	7 5/8	7 5/8	7 3/4	7 3/4	7 3/4	7 3/4
8"	A	n/a	n/a	3	2 3/4	2 5/8	2 1/2	2 1/2	2 3/8	2 3/8	2 2/8	2 1/4
	B	n/a	n/a	8 3/4	9 1/8	9 1/4	9 3/8	9 1/2	9 4/8	9 5/8	9 5/8	9 5/8

Diffuser Width	Dimension*	Pipe Diameter									
		30"	32"	34"	36"	38"	40"	42"	44"	46"	48"
4"	A	1 7/8	1 7/8	1 7/8	1 7/8	1 7/8	1 7/8	1 7/8	1 7/8	1 3/4	1 3/4
	B	5 7/8	5 7/8	5 7/8	5 7/8	5 7/8	5 7/8	5 7/8	5 7/8	5 7/8	5 7/8
6"	A	2	2	2	2	2	1 7/8	1 7/8	1 7/8	1 7/8	1 7/8
	B	7 3/4	7 3/4	7 3/4	7 3/4	7 3/4	7 3/4	7 3/4	7 3/4	7 3/4	7 3/4
8"	A	2 2/8	2 1/8	2 1/8	2 1/8	2 1/8	2 1/8	2 1/8	2	2	2
	B	9 3/4	9 3/4	9 3/4	9 3/4	9 3/4	9 3/4	9 3/4	9 3/4	9 3/4	9 3/4

* A/B dimensions defined in product drawings are dependent on size of spiral pipe for which product is designed.

Performance Data: RS34 Series

Duct Size	Core Eff. Area (ft ²)	Neck Velocity (FPM) Velocity Pressure	300	400	500	600	700	800	1000	1200	1400
			0.004	0.008	0.013	0.018	0.025	0.033	0.051	0.074	0.100
8x4	0.151	CFM	45	60	75	90	106	121	151	181	211
		NC	<20	<20	<20	20	25	30	35	40	45
		Throw (ft.)	3 4 5 4 5 7 6 7.5 9 7 8 10 9 10 14 10 11 15 10 12 20 12 14 20 15 17 27								
10x4	0.191	CFM	57	76	95	115	134	153	191	229	267
		NC	<20	<20	<20	20	25	30	35	40	45
		Throw (ft.)	5 5.5 6.5 6 7 9 8 9 11 9 10 14 11 12 16 12 13.5 18 14 16 24 16 18 28 19 22 32								
12x4	0.231	CFM	69	92	116	139	162	185	231	277	323
		NC	<20	<20	<20	20	25	30	35	40	45
		Throw (ft.)	5 5.5 6.5 6 7 9 8 9 11 9 10 14 11 12 16 12 13.5 18 14 16 24 16 18 28 19 22 32								
14x4	0.271	CFM	81	108	136	163	190	217	271	325	380
		NC	<20	<20	<20	20	25	30	35	40	45
		Throw (ft.)	5 6.5 7.5 7 8 10 10 11 13 11 12 16 13 14.5 20 14 16 22 16 19 29 19 22 34 22 26 40								
10x6	0.299	CFM	90	120	150	180	210	240	299	359	419
		NC	<20	<20	<20	20	25	30	35	40	45
		Throw (ft.)	5 6.5 7.5 7 8 10 10 11 13 11 12 16 13 14.5 20 14 16 22 16 19 29 19 22 34 22 26 40								
12x6	0.362	CFM	109	145	181	217	254	290	362	435	507
		NC	<20	<20	<20	20	25	30	35	40	45-50
		Throw (ft.)	6 7 8 8 9 11 10 11.5 14 12 13 18 14 16 21 16 18 24 18 21 32 22 26 38 25 30 44								
14x6	0.425	CFM	128	170	213	255	298	340	425	510	595
		NC	<20	<20	<20	20	25	30	35	40	45-50
		Throw (ft.)	6 7.5 9 9 10 12 11 11.5 14.5 12 13.5 19 14 16 22 17 19 25 19 22 33 22 26 39 25 30 45								
16x6	0.488	CFM	146	195	244	293	342	391	488	586	684
		NC	<20	<20	<20	20	25	30	35	40	45-50
		Throw (ft.)	7 8 10 9 10 12 11 12.5 16 13 14.5 20 15 17 23 17 20 26 19 22 34 23 27 40 26 31 46								
18x6	0.551	CFM	165	220	276	331	386	441	551	661	772
		NC	<20	<20	<20	20	25	30	35	40	45-50
		Throw (ft.)	7 8 10 9 10 12 11 12.5 16 13 14.5 20 15 17 23 17 20 27 20 23 34 23 27 41 26 31 47								
14x8	0.580	CFM	174	232	290	348	406	464	580	695	811
		NC	<20	<20	<20	20	25	30	35	40	45-50
		Throw (ft.)	7 8 10 9 10.5 12.5 12 13 17 13 15 21 16 18 24 18 21 28 20 23 36 24 28 43 28 33 49								
16x8	0.665	CFM	200	266	333	399	466	532	665	798	931
		NC	<20	<20	<20	20	25	30	35-40	40-45	>50
		Throw (ft.)	8 8.5 10.5 10 11 13.5 13 14.5 18 14 16 22 17 19 26 18 21 29 21 25 38 25 30 45 30 35 52								
18x8	0.751	CFM	225	300	376	451	526	601	751	901	1051
		NC	<20	<20	<20	20	25	30	35-40	40-45	>50
		Throw (ft.)	8 9 11 10 11.5 14.5 14 16 19 15 17 23 17 20 27 19 22 30 22 26 40 27 32 48 31 37 55								

Performance Notes:

- 1 Performance data calculated with blades set at 0°
- 2 Engineering based off nominal face dimension
- 3 Additional performance data for sizes not listed is available at www.shoemakerfmfg.com
- 4 Throw values are measured in feet for terminal velocities of 150/100/50 FPM
- 5 Throw data is based on supply air and room air both at isothermal conditions
- 6 Effective core areas listed in chart are defined as the measurement of space between the blades actually being utilized by the air
- 7 Data obtained from tests conducted in accordance with ANSI/ASHRAE standard 70-2006

RS52 Series Dimensions

Diffuser Width	Dimension*	Pipe Diameter										
		8"	10"	12"	14"	16"	18"	20"	22"	24"	26"	28"
4"	A	1 1/4	1 1/8	1 1/8	1 1/8	1	1	1	1	1	1	1
	B	5 3/8	5 1/2	5 5/8	5 3/4	5 3/4	5 3/4	5 3/4	5 3/4	5 7/8	5 7/8	5 7/8
6"	A	n/a	1 5/8	1 1/2	1 3/8	1 3/8	1 1/4	1 1/4	1 1/4	1 1/8	1 1/8	1 1/8
	B	n/a	7 1/8	7 3/8	7 1/2	7 1/2	7 5/8	7 5/8	7 3/4	7 3/4	7 3/4	7 3/4
8"	A	n/a	n/a	2 1/8	1 7/8	1 3/4	1 5/8	1 5/8	1 1/2	1 1/2	1 3/8	1 3/8
	B	n/a	n/a	8 3/4	9 1/8	9 1/4	9 3/8	9 1/2	9 1/2	9 5/8	9 5/8	9 5/8

Diffuser Width	Dimension*	Pipe Diameter									
		30"	32"	34"	36"	38"	40"	42"	44"	46"	48"
4"	A	1	1	1	1	1	1	1	1	7/8	7/8
	B	5 7/8	5 7/8	5 7/8	5 7/8	5 7/8	5 7/8	5 7/8	5 7/8	5 7/8	5 7/8
6"	A	1 1/8	1 1/8	1 1/8	1 1/8	1 1/8	1	1	1	1	1
	B	7 3/4	7 3/4	7 3/4	7 3/4	7 3/4	7 3/4	7 3/4	7 3/4	7 3/4	7 3/4
8"	A	1 3/8	1 1/4	1 1/4	1 1/4	1 1/4	1 2/9	1 1/4	1 1/8	1 1/8	1 1/8
	B	9 3/4	9 3/4	9 3/4	9 3/4	9 3/4	9 3/4	9 3/4	9 3/4	9 3/4	9 3/4

* A/B dimensions defined in product drawings are dependent on size of spiral pipe for which product is designed for.

Performance Data: RS52 Series

Duct Size	Core Eff. Area (ft ²)	Neck Velocity (FPM) Velocity Pressure	300	400	500	600	700	800	1000	1200	1400
			0.004	0.008	0.013	0.018	0.025	0.033	0.051	0.074	0.100
8x4	0.166	CFM	50	66	83	99	116	132	166	199	232
		NC	<20	<20	<20	20	25	30	35	40	45
		Throw (ft.)	4 4.5 5.5	5 6 7.5	7 7.5 8.5	8 8 10	8 9 12	9 10 14	11 13 18	12 14 20	15 17 27
10x4	0.210	CFM	63	84	105	126	147	168	210	252	293
		NC	<20	<20	<20	20	25	30	35	40	45
		Throw (ft.)	4 5 6	5 6.5 8.5	8 8.5 9.5	7 8.5 11	10 11 15	11 12 16	13 14 20	14 16 24	18 20 29
12x4	0.254	CFM	76	101	127	152	178	203	254	304	355
		NC	<20	<20	<20	20	25	30	35	40	45
		Throw (ft.)	5 5.5 6.5	6 7 9	8 9 11	9 10 14	11 12 16	12 13.5 18	14 16 24	16 18 28	19 22 32
14x4	0.298	CFM	89	119	149	179	208	238	298	357	417
		NC	<20	<20	<20	20	25	30	35	40	45
		Throw (ft.)	5 6 7	6 7.5 9.5	9 10 12	10 11 15	12 14 19	13 15 20	16 18 27	18 21 33	21 24 38
10x6	0.329	CFM	99	132	165	198	231	264	329	395	461
		NC	<20	<20	<20	20	25	30	35	40	45
		Throw (ft.)	5 6.5 7.5	7 8 10	10 11 13	11 12 16	13 14.5 20	14 16 22	17 19 29	19 22 34	22 26 40
12x6	0.399	CFM	120	159	199	239	279	319	399	478	558
		NC	<20	<20	<20	20	25	30	35	40	45-50
		Throw (ft.)	6 7 9	9 10 12	10 11.5 14.5	12 13.5 18	14 16 22	16 18 24	19 22 32	22 26 38	25 30 44
14x6	0.468	CFM	140	187	234	281	328	374	468	561	655
		NC	<20	<20	<20	20	25	30	35	40	45-50
		Throw (ft.)	7 8 10	10 11 13	11 13 16	14 16 21	15 17 23	18 20 27	20 23 35	24 28 42	27 33 49
16x6	0.537	CFM	161	215	269	322	376	430	537	645	752
		NC	<20	<20	<20	20	25	30	35	40	45-50
		Throw (ft.)	8 8.5 11	10 11.5 13.5	12 13.5 17	14 16 22	16 18 25	18 20 28	21 24 36	25 29 45	28 34 52
18x6	0.606	CFM	182	243	303	364	424	485	606	728	849
		NC	<20	<20	<20	20	25	30	35	40	45-50
		Throw (ft.)	8 8.5 11	10 11.5 14.5	12 14.5 18	15 17 23	18 20 27	19 22 30	22 26 38	26 31 47	29 36 54
14x8	0.638	CFM	191	255	319	383	447	510	638	766	893
		NC	<20	<20	<20	20	25	30	35	40	45-50
		Throw (ft.)	8 9 11.5	11 13 16	14 16 19	16 18 24	19 21 28	20 23 31	23 27 39	27 32 48	30 37 55
16x8	0.732	CFM	220	293	366	439	513	586	732	879	1025
		NC	<20	<20	<20	20	25	30	35-40	40-50	>50
		Throw (ft.)	9 10 12.5	12 14 17	15 17 20	17 19 25	20 23 30	22 25 33	25 29 41	29 35 51	32 40 58
18x8	0.827	CFM	248	331	413	496	579	661	827	992	1158
		NC	<20	<20	<20	20	25	30	35-40	40-50	>50
		Throw (ft.)	9 10 12.5	12 14 18	16 18 21	18 20 26	20 23 34	23 26 35	26 30 46	30 36 55	34 42 65

Performance Notes:

- Performance data calculated with blades set at 0°
- Engineering based off nominal face dimension
- Additional performance data for sizes not listed is available at www.shoemakerfmg.com
- Throw values are measured in feet for terminal velocities of 150/100/50 FPM
- Throw data is based on supply air and room air both at isothermal conditions
- Effective core areas listed in chart are defined as the measurement of space between the blades actually being utilized by the air
- Data obtained from tests conducted in accordance with ANSI/ASHRAE standard 70-2006

DOOR GRILLE



4000 Series Aluminum Transfer Door Grille

Standard Features:

- Extruded aluminum transfer door grille, single frame with signature line marks
- Designed for high air capacities
- Designed to minimize vision through grille
- Accommodates door thicknesses ranging from 1 1/4" to 2 1/4"
- Countersunk mounting holes for flush appearance with color matching Phillips posi-drive screws
- Rust resistant pre-coat with durable powder finish
- Driftwood Tan

Options:

- Aluminum Transfer Door Grille with additional loose frame
- MODEL: 4100**

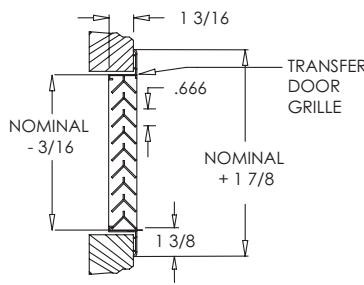

4000 SERIES

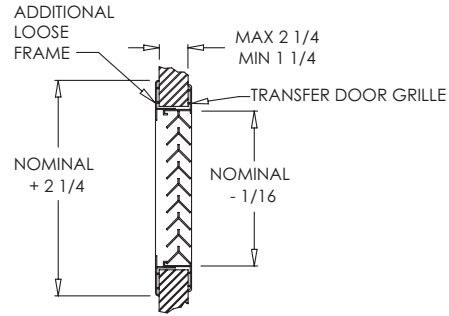

4100 SERIES

Performance Data: 4000 Series

Size	Eff. Area (ft ²)	Neck Velocity (FPM) Velocity Pressure	300	400	500	600	700	800	900
			0.180	0.250	0.400	0.610	0.820	1.100	1.400
10×10	0.305	CFM	92	122	153	183	214	244	275
		NC	<20	<20	<20	<20	20-25	25-30	30-35
12×12	0.439	CFM	132	176	220	264	307	351	395
		NC	<20	<20	<20	<20	20-25	25-30	30-35
14×14	0.598	CFM	179	239	299	359	418	478	538
		NC	<20	<20	<20	20-25	25-30	30-35	35-40
20×12	0.745	CFM	223	298	372	447	521	596	670
		NC	<20	<20	<20	20-25	25-30	30-35	35-40
16×16	0.780	CFM	234	312	390	468	546	624	702
		NC	<20	<20	<20	20-25	25-30	30-35	35-40
24×12	0.898	CFM	269	359	449	539	628	718	808
		NC	<20	<20	20-25	25-30	30-35	35-40	40-45
18×18	0.987	CFM	296	395	494	592	691	790	889
		NC	<20	<20	20-25	25-30	30-35	35-40	40-45
24×16	1.183	CFM	355	473	592	710	828	947	1065
		NC	<20	<20	20-25	25-30	30-35	35-40	40-45
20×20	1.219	CFM	366	488	609	731	853	975	1097
		NC	<20	<20	25-30	30-35	35	35-40	40-45
24×18	1.326	CFM	398	530	663	796	928	1061	1193
		NC	<20	<20	25-30	30-35	35	35-40	40-45
24×24	1.754	CFM	526	702	877	1053	1228	1403	1579
		NC	<20	20-25	25-30	30-35	35	35-40	40-45

Performance Notes:

1 Additional performance data for sizes not listed is available at www.shoemakerfmfg.com

2 Effective core areas listed in chart are defined as the measurement of space between the blades actually being utilized by the air

3 Data obtained from tests conducted in accordance with ANSI/ASHRAE standard 70-2006

ADJUSTABLE BLADE DIFFUSERS

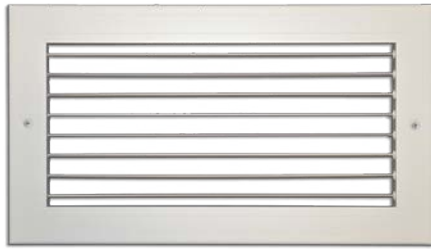

901/931 – Blades parallel to longest dimension

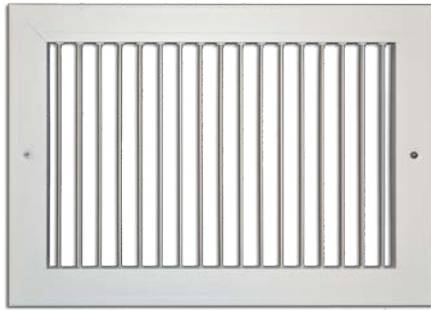

902/932 – Blades parallel to shortest dimension

901/931

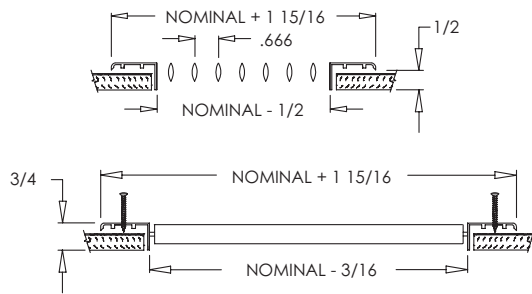

901-0/931-0

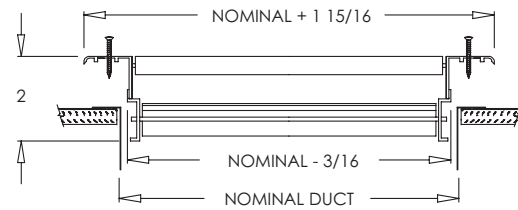
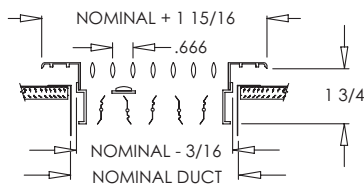

902/932

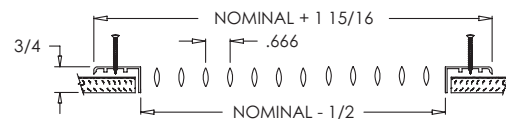
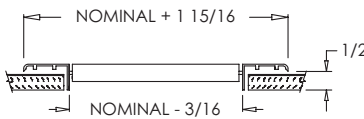

902-0/932-0

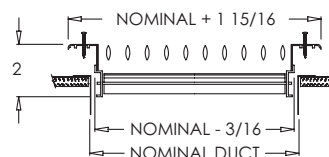
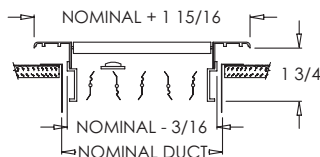

901/902 and 931/932 Series Single Deflection Adjustable Blade Diffusers

Standard Features:

- Single deflection surface mount diffuser
- Provides 2-way air flow on one plane
- Nylon bushings on adj. blades prevent metal on metal rattle
- Countersunk mounting holes for flush appearance with color matching Phillips posi-drive screws
- Rust resistant pre-coat with durable powder finish
- Soft White

MODEL: 901/902

- Extruded aluminum surface mount frame with signature line marks
- Adjustable airfoil blades
 - 901 – Blades are parallel to longest dimension
 - 902 – Blades are parallel to shortest dimension



MODEL: 931/932





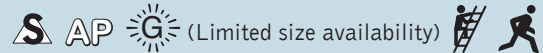

- Adjustable steel blades
 - 931 – Blades are parallel to longest dimension
 - 932 – Blades are parallel to shortest dimension
- Available in even sizes up to 36" x 24"

Options:

- See chart on following page for options



901, 902, 931, 932 Series Options

OPTIONS	901	902	931	932
Standard Colors 	✓	✓	✓	✓
Designer Colors 	✓	✓		
Aluminum Paint 	✓	✓	✓	✓
Satin Anodized 	✓	✓		
Field Adjustable 	✓	✓	✓	✓
MRI Compatible 	✓	✓		
Expedited Services 	✓	✓	✓	✓
Screwdriver operated Opposed Blade Damper	✓	✓	✓	✓
2" ADC compliant round collar with bead for ease of installation (square sizes only)	✓	✓	✓	✓
Heavy duty construction	✓	✓		
Insect Screen	✓	✓		
Fractional, exact I.D. and O.D. sizes	✓	✓		
T-20 Tamper Proof Screws	✓	✓	✓	✓

Performance Data: 901, 902, 931, 932 Series

Duct Size	Core Eff. Area (ft ²)	Neck Velocity (FPM) Velocity Pressure	Velocity Pressure														
			300 0.004	400 0.008	500 0.013	600 0.018	700 0.025	800 0.033	1000 0.051	1200 0.074	1400 0.100						
10×4	0.210	CFM	63	84	105	126	147	168	210	252	293						
		NC	<20	<20	<20	20	25	30	35	40	45						
		Throw (ft.)	4 5 6 5 6.5 8.5 8 8.5 9.5 7 8.5 11 10 11 15 11 12 16 13 14 20 14 16 24 18 20 29														
8×6 12×4	0.260	CFM	78	104	130	156	182	208	260	312	364						
		NC	<20	<20	<20	20	25	30	35	40	45						
		Throw (ft.)	5 5.5 6.5 6 7 9 8 9 11 9 10 14 11 12 16 12 13.5 18 14 16 24 16 18 28 19 22 32														
14×4	0.298	CFM	89	119	149	179	208	238	298	357	417						
		NC	<20	<20	<20	20	25	30	35	40	45						
		Throw (ft.)	5 6 7 6 7.5 9.5 9 10 12 10 11 15 12 14 19 13 15 20 16 18 27 18 21 33 21 24 38														
10×6 16×4	0.329	CFM	99	132	165	198	231	264	329	395	461						
		NC	<20	<20	<20	20	25	30	35	40	45						
		Throw (ft.)	5 6.5 7.5 7 8 10 10 11 13 11 12 16 13 14.5 20 14 16 22 17 19 29 19 22 34 22 26 40														
12×6 18×4	0.399	CFM	120	159	199	239	279	319	399	478	558						
		NC	<20	<20	<20	20	25	30	35	40	45-50						
		Throw (ft.)	6 7 9 9 10 12 10 11.5 14.5 12 13.5 18 14 16 22 16 18 24 19 22 32 22 26 38 25 30 44														
10×8 14×6	0.449	CFM	135	180	225	270	314	359	449	539	629						
		NC	<20	<20	<20	20	25	30	35	40	45-50						
		Throw (ft.)	7 8 10 10 11 13 11 13 16 14 16 21 15 17 23 18 20 27 20 23 35 24 28 42 27 33 49														
12×8 16×6	0.544	CFM	163	217	272	326	381	435	544	652	761						
		NC	<20	<20	<20	20	25	30	35	40	45-50						
		Throw (ft.)	8 8.5 11 10 11.5 13.5 12 13.5 17 14 16 22 16 18 25 18 20 28 21 24 36 25 29 45 28 34 52														
10×10 18×6	0.569	CFM	171	228	285	341	398	455	569	683	797						
		NC	<20	<20	<20	20	25	30	35	40	45-50						
		Throw (ft.)	8 8.5 11 10 11.5 14.5 12 14.5 18 15 17 23 18 20 27 19 22 30 22 26 38 26 31 47 29 36 54														
14×8	0.638	CFM	191	255	319	383	447	510	638	766	893						
		NC	<20	<20	<20	20	25	30	35	40	45-50						
		Throw (ft.)	8 9 11.5 11 13 16 4 16 19 16 18 24 19 21 28 20 23 31 23 27 39 27 32 48 30 37 55														
12×12 14×10	0.834	CFM	250	333	417	500	583	667	834	1000	1167						
		NC	<20	<20	<20	20	25	30	35-40	40-50	>50						
		Throw (ft.)	9 10 12.5 12 14 18 16 18 21 18 20 26 20 23 34 23 26 35 25 30 46 30 36 55 33 42 65														
14×14 20×10	1.148	CFM	345	459	574	689	804	919	1148	1378	1608						
		NC	<20	<20	20	25	30	30-35	35-40	40-45	>50						
		Throw (ft.)	10 11.5 14.5 14 16 20 18 20 24 19 22 30 23 26 37 25 30 40 29 35 53 34 42 62 40 49 73														
16×16	1.514	CFM	454	605	757	908	1060	1211	1514	1816	2119						
		NC	<20	<20	20	25	30	30-35	35-40	40-45	>50						
		Throw (ft.)	12 13 16 16 18 22 19 22 26 22 25 35 25 30 41 28 34 46 32 39 60 38 47 71 46 57 83														
24×12 28×10	1.702	CFM	511	681	851	1021	1191	1362	1702	2042	2383						
		NC	<20	<20	20	25	30	30-35	35-40	40-45	>50						
		Throw (ft.)	13 14.5 18 17 19 23 20 23 28 23 27 37 27 32 43 29 36 48 34 42 64 41 50 76 48 59 89														
24×24 36×16	3.465	CFM	1039	1386	1732	2079	2425	2772	3465	4158	4850						
		NC	<20	20	25	30	30-35	35-40	45-50	>50	>50						
		Throw (ft.)	20 23 29 24 29 35 27 33 45 31 38 52 36 44 60 42 52 78 50 62 94 60 73 109 69 85 126														

Performance Notes:

- Performance data calculated with blades set at 0°
- Additional performance data for sizes not listed is available at www.shoemakerfmg.com
- Throw values are measured in feet for terminal velocities of 150/100/50 FPM
- Throw data is based on supply air and room air both at isothermal conditions
- Effective core areas listed in chart are defined as the measurement of space between the blades actually being utilized by the air
- Data obtained from tests conducted in accordance with ANSI/ASHRAE standard 70-2006

ADJUSTABLE BLADE DIFFUSERS

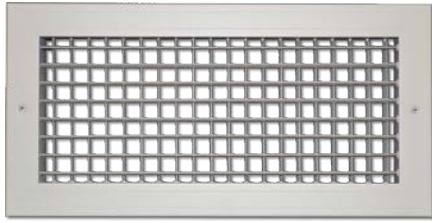

903/933 – Front blades parallel to longest dimension, back blades parallel to shortest dimension

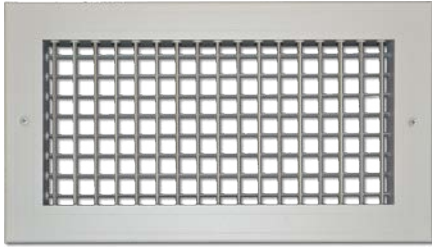

904/934 – Front blades parallel to shortest dimension, back blades parallel to longest dimension

903/933

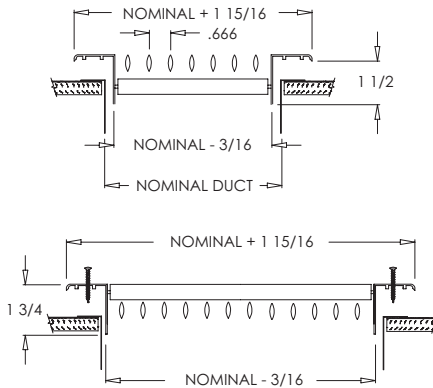

903/904 and 933/934 Series Double Deflection Adjustable Blade Diffusers

Standard Features:

- Double deflection surface mount diffuser
- Provides 4-way air flow on one plane
- Nylon bushings on adj. blades prevent metal on metal rattle
- Countersunk mounting holes for flush appearance with color matching Phillips posi-drive screws
- Rust resistant pre-coat with durable powder finish
- Soft White

MODEL: 903/904

- Extruded aluminum surface mount frame with signature line marks
- Adjustable airfoil blades
 - 903 – Front blades parallel to longest dimension, back blades parallel to shortest dimension
 - 904 – Front blades parallel to shortest dimension, back blades parallel to longest dimension



MODEL: 933/934

- Adjustable steel blades
 - 933 – Front blades parallel to longest dimension, back blades parallel to shortest dimension
 - 934 – Front blades parallel to shortest dimension, back blades parallel to longest dimension
- Available in even sizes up to 36" x 24"

Options:

- See chart on following page for options

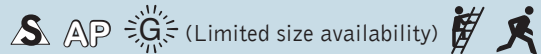

903-0/933-0

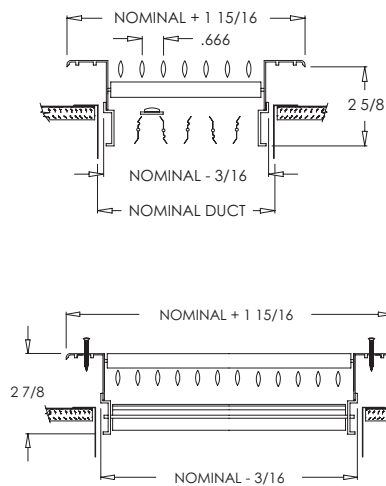



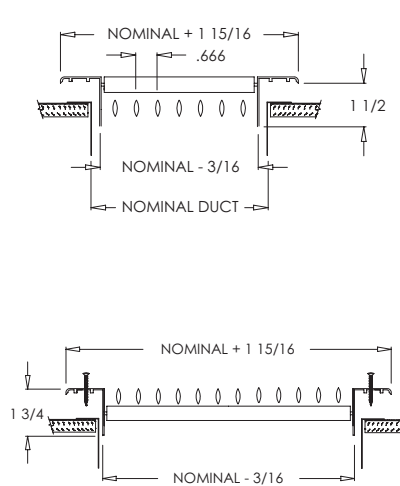

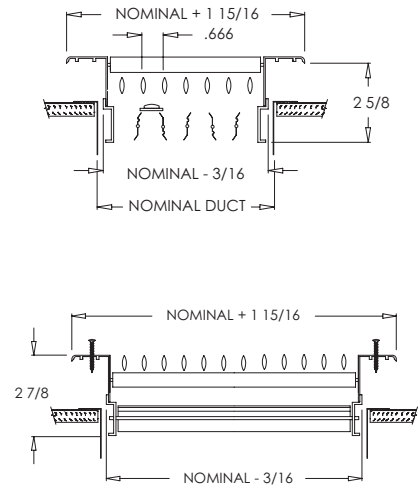

904/934



904-0/934-0



903, 904, 933, 934 Series Options

OPTIONS	903	904	933	934
Standard Colors 	✓	✓	✓	✓
Designer Colors 	✓	✓		
Aluminum Paint 	✓	✓	✓	✓
Satin Anodized 	✓	✓		
Field Adjustable 	✓	✓	✓	✓
MRI Compatible 	✓	✓		
Expedited Services 	✓	✓	✓	✓
2" ADC compliant round collar with bead for ease of installation (square sizes only)	✓	✓	✓	✓
Heavy duty construction	✓	✓		
Insect Screen	✓	✓		
Fractional, exact I.D. and O.D. sizes	✓	✓		
T-20 Tamper Proof Screws	✓	✓	✓	✓

Performance Data: 903, 904, 933, 934 Series

Duct Size	Core Eff. Area (ft ²)	Neck Velocity (FPM) Velocity Pressure	Velocity Pressure														
			300 0.004	400 0.008	500 0.013	600 0.018	700 0.025	800 0.033	1000 0.051	1200 0.074	1400 0.100						
10x4	0.191	CFM	57	76	95	115	134	153	191	229	267						
		NC	<20	<20	<20	20	25	30	35	40	45						
8x6 12x4	0.237	CFM	5 5.5 6.5 6	7 9	8 9 11	9 10 14	11 12 16	12 13.5 18	14 16 24	16 18 28	19 22 32						
		NC	<20	<20	<20	20	25	30	35	40	45						
14x4	0.271	CFM	81	108	136	163	190	217	271	325	380						
		NC	<20	<20	<20	20	25	30	35	40	45						
10x6 16x4	0.311	CFM	93	125	156	187	218	249	311	374	436						
		NC	<20	<20	<20	20	25	30	35	40	45						
12x6 18x4	0.362	CFM	109	145	181	217	254	290	362	435	507						
		NC	<20	<20	<20	20	25	30	35	40	45-50						
10x8 14x6	0.425	CFM	6 7 8 8	9 11	10 11.5 14	12 13 18	14 16 21	16 18 24	18 21 32	22 26 38	25 30 44						
		NC	<20	<20	<20	20	25	30	35	40	45-50						
12x8 16x6	0.494	CFM	6 7.5 9 9	10 12	11 11.5 14.5	12 13.5 19	14 16 22	17 19 25	19 22 33	22 26 39	25 30 45						
		NC	<20	<20	<20	20	25	30	35	40	45-50						
10x10 18x6	0.517	CFM	7 8 10 9	10 12	11 12.5 16	13 14.5 20	15 17 23	17 20 26	19 22 34	23 27 40	26 31 46						
		NC	<20	<20	<20	20	25	30	35	40	45-50						
14x8	0.580	CFM	7 8 10 9	10.5 12.5	12 13 17	13 15 21	16 18 24	18 21 28	20 23 36	24 28 43	28 33 49						
		NC	<20	<20	<20	20	25	30	35	40	45-50						
12x12 18x8	0.757	CFM	8 9 11 10	11.5 14.5	14 16 19	15 17 23	17 20 27	19 22 30	22 26 40	27 32 48	31 37 55						
		NC	<20	<20	<20	20	25	30	35-40	40-45	>55						
14x14 20x10	1.042	CFM	10 11.5 14.5	14 16 20	17 20 24	19 22 30	22 26 37	25 30 40	29 35 53	35 42 62	40 49 73						
		NC	<20	<20	20	25	30	30-35	35-40	40-45	>55						
16x16	1.373	CFM	12 13 16 16	18 22	19 22 26	21 25 35	25 30 41	28 34 46	33 39 60	38 47 71	46 57 83						
		NC	<20	<20	20	25	30	30-35	35-40	40-45	>55						
24x12 28x10	1.545	CFM	13 14.5 18	17 19 23	20 23 28	23 27 37	27 32 43	30 36 48	35 42 64	40 50 76	48 59 89						
		NC	<20	<20	20	25	30	30-35	35-40	40-45	>55						
24x24 36x16	3.154	CFM	946	1262	1577	1893	2208	2523	3154	3785	4416						
		NC	<20	20	25	30	30-35	35-40	45-50	50-55	>55						
		Throw (ft.)	17 19 23	22 25 31	26 31 37	29 35 47	33 40 54	38 46 62	43 54 79	51 64 95	60 75 111						

Performance Notes:

- 1 Performance data calculated with blades set at 0°
- 2 Additional performance data for sizes not listed is available at www.shoemakerfmg.com
- 3 Throw values are measured in feet for terminal velocities of 150/100/50 FPM
- 4 Throw data is based on supply air and room air both at isothermal conditions
- 5 Effective core areas listed in chart are defined as the measurement of space between the blades actually being utilized by the air
- 6 Data obtained from tests conducted in accordance with ANSI/ASHRAE standard 70-2006



Field Adjustable



High Capacity



MRI Compatible



Multi-Family



Expedited Service



Extended Leadtime

FIXED BLADE GRILLES

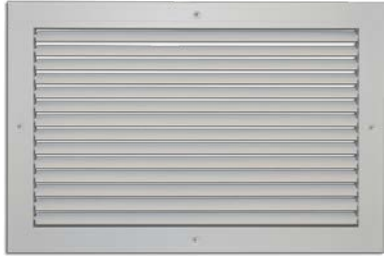

905/935 – 45° fixed blades parallel to longest dimension



906/936 – 45° fixed blades parallel to shortest dimension

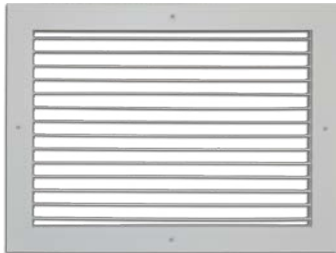

907/937 – 0° fixed blades parallel to longest dimension



908/938 – 0° fixed blades parallel to shortest dimension

905–908 and 935–938 Series Fixed Blade Return Air Grilles

Standard Features:

- Surface mount fixed blade grille
- Blades spaced at 2/3"
- Countersunk mounting holes for flush appearance with color matching Phillips posi-drive screws
- Rust resistant pre-coat with durable powder finish
- Soft White

905/906

- Extruded aluminum surface mount frame with signature line marks
- Fixed airfoil blades at 45 °
 - 905 – Blades are parallel to longest dimension
 - 906 – Blades are parallel to shortest dimension



907/908

- Extruded aluminum surface mount frame with signature line marks
- Fixed airfoil blades at 0°
 - 907 – Blades are parallel to longest dimension
 - 908 – Blades are parallel to shortest dimension



935/936

- Fixed steel blades at 45 °
 - 935 – Blades are parallel to longest dimension
 - 936 – Blades are parallel to shortest dimension
- Available in even sizes up to 36"×24"



937/938

- Fixed steel blades at 0°
 - 937 – Blades are parallel to longest dimension
 - 938 – Blades are parallel to shortest dimension
- Available in even sizes up to 36"×24"



905–908/935–938 Series Options

OPTIONS	905	906	907	908	935	936	937	938
Standard Colors	✓	✓	✓	✓	✓	✓	✓	✓
Designer Colors	✓	✓	✓	✓				
Satin Anodized	✓	✓	✓	✓				
Aluminum Paint	✓	✓	✓	✓	✓	✓	✓	✓
MRI Compatible	✓	✓	✓	✓				
Expedited Services	✓	✓	✓	✓	✓	✓	✓	✓
Screwdriver operated Opposed Blade Damper	✓	✓	✓	✓	✓	✓	✓	✓
2" ADC compliant round collar with bead for ease of installation (square sizes only)	✓	✓	✓	✓	✓	✓	✓	✓
Heavy duty construction	✓	✓	✓	✓				
Insect Screen	✓	✓	✓	✓				
Fractional, exact I.D. and O.D. sizes	✓	✓	✓	✓				
T-20 Tamper Proof Screws	✓	✓	✓	✓	✓	✓	✓	✓

FIXED BLADE GRILLES

905/935

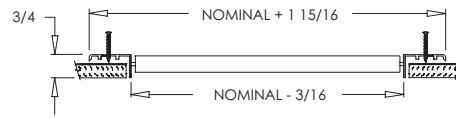
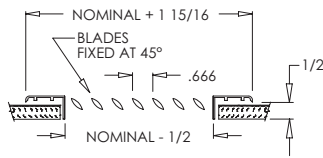

905-0/935-0

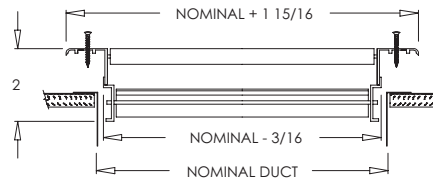
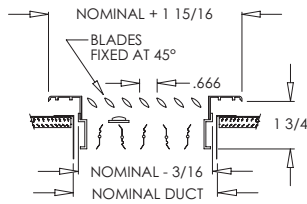

906/936

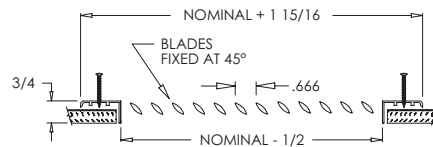
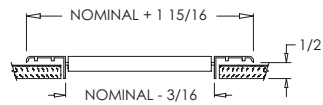

906-0/936-0

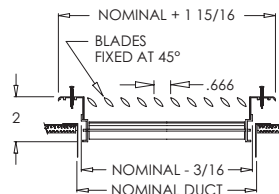
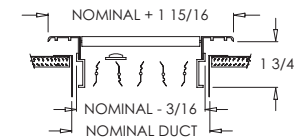

907/937

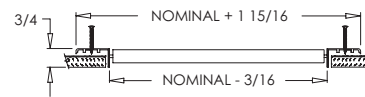
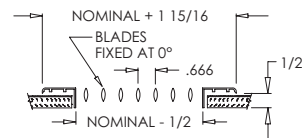

907-0/937-0

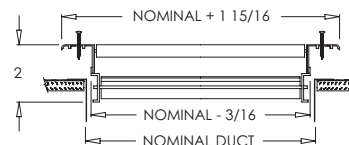
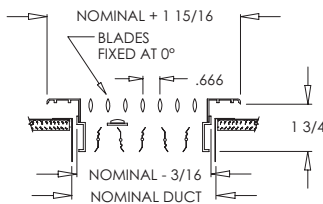

908/938

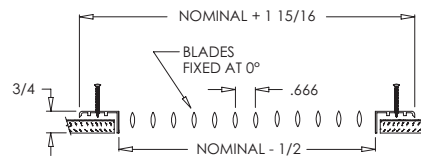
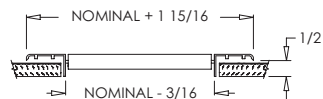

908-0/938-0

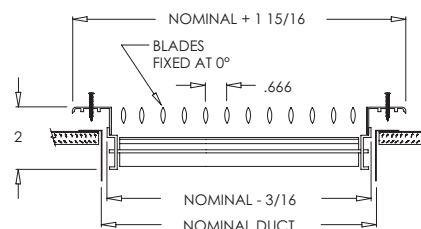
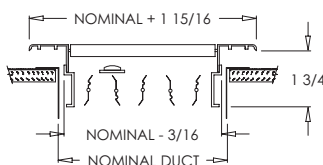

Performance Data: 905, 906, 935, 936 Series

Duct Size	Core Eff. Area (ft ²)	Neck Velocity (FPM) Velocity Pressure	400	500	600	700	800	900	1000
			0.032	0.048	0.070	0.092	0.120	0.140	0.160
8×4	0.154	CFM	62	77	92	108	123	138	154
		NC	<20	<20	20-25	25-30	30-35	30-35	35
6×6	0.182	CFM	73	91	109	128	146	164	182
		NC	<20	<20	20-25	25-30	30-35	30-35	35
10×4	0.195	CFM	78	97	117	136	156	175	195
		NC	<20	<20	20-25	30	30-35	35	35-40
8×6	0.248	CFM	99	124	149	174	199	224	248
		NC	<20	<20	20-25	30	35	35	35-40
10×6	0.314	CFM	126	157	189	220	252	283	314
		NC	<20	20-25	30	30-35	35	35-40	40
8×8	0.343	CFM	137	171	206	240	274	309	343
		NC	<20	<20	20-25	30	35	35-40	40
12×6	0.381	CFM	152	190	228	266	304	342	381
		NC	<20	20-25	30	30-35	35	35-40	40
14×6	0.447	CFM	179	223	268	313	357	402	447
		NC	<20	25-30	30	30-35	35-40	40	40-45
10×10	0.554	CFM	222	277	332	388	443	499	554
		NC	20-25	25-30	30	30-35	35-40	40	40-45
14×8	0.617	CFM	247	308	370	432	493	555	617
		NC	20-25	25-30	30-35	35	40	40-45	45
12×12	0.815	CFM	326	408	489	571	652	734	815
		NC	20-25	25-30	30-35	35	35-40	40-45	45
14×14	1.127	CFM	451	564	676	789	902	1014	1127
		NC	20-25	30	30-35	35-40	40-45	40-45	>45
20×10	1.136	CFM	454	568	682	795	909	1023	1136
		NC	20-25	30-35	35	35-40	40-45	40-45	>45
18×12	1.240	CFM	496	620	744	868	992	1116	1240
		NC	20-25	30-35	35	35-40	40-45	40-45	>45
16×16	1.489	CFM	596	745	894	1042	1191	1340	1489
		NC	20-25	30	30-35	35-40	40-45	40-45	>45
24×12	1.665	CFM	666	833	999	1166	1332	1499	1665
		NC	25	30-35	35	35-40	40-45	40-45	<50
18×18	1.902	CFM	761	951	1141	1331	1521	1712	1902
		NC	25	30-35	35-40	35-40	40-45	45	>45
30×12	2.090	CFM	836	1045	1254	1463	1672	1881	2090
		NC	25	30-35	35-40	40	40-45	45-50	50
20×20	2.364	CFM	946	1182	1419	1655	1892	2128	2364
		NC	25-30	30-35	35-40	40	40-45	45-50	<50
24×20	2.849	CFM	1140	1425	1709	1994	2279	2564	2849
		NC	25-30	30-35	35-40	40-45	45	45-50	50
22×22	2.878	CFM	1151	1439	1727	2014	2302	2590	2878
		NC	25-30	35	35-40	40-45	45	45-50	50
30×18	3.204	CFM	1282	1602	1923	2243	2564	2884	3204
		NC	25-30	30-35	35-40	40-45	45	45-50	>50
24×24	3.441	CFM	1376	1721	2065	2409	2753	3097	3441
		NC	25-30	35	35-40	40-50	45-50	45-50	50
30×20	3.576	CFM	1430	1788	2146	2503	2861	3218	3576
		NC	25-30	30-35	35-40	40-45	45-50	45-50	>50
36×18	3.856	CFM	1542	1928	2313	2699	3085	3470	3856
		NC	25-30	35-40	40	40-45	45-50	45-50	>50
30×24	4.319	CFM	1728	2160	2591	3023	3455	3887	4319
		NC	25-30	35	35-40	40-45	45-50	50	>50
36×24	5.197	CFM	2079	2598	3118	3638	4158	4677	5197
		NC	25-30	35-40	40	40-45	45-50	50	50-55
30×30	5.434	CFM	2173	2717	3260	3804	4347	4890	5434
		NC	25-30	35-40	40	40-45	45-50	>50	>50
36×30	6.538	CFM	2615	3269	3923	4577	5230	5884	6538
		NC	30	35-40	40-45	45	50	>50	>50
48×24	6.953	CFM	2781	3476	4172	4867	5562	6258	6953
		NC	30	35-40	40-45	45	50	50-55	50-55
36×36	7.879	CFM	3152	3940	4728	5515	6303	7091	7879
		NC	30-35	35-40	40-45	45	50-55	50-55	55
48×36	10.541	CFM	4217	5271	6325	7379	8433	9487	10541
		NC	30-35	35-40	40-45	45-50	50-55	50-55	>55
48×48	14.130	CFM	5652	7065	8478	9891	11304	12717	14130
		NC	35	35-40	40-45	45-50	50-55	55	>55

Performance Notes:

1 Additional performance data for sizes not listed is available at www.shoemakerfmg.com

2 Effective core areas listed in chart are defined as the measurement of space between the blades actually being utilized by the air

3 Data obtained from tests conducted in accordance with ANSI/ASHRAE standard 70-2006



Performance Data: 907, 908, 937, 938 Series

Duct Size	Core Eff. Area (ft ²)	Neck Velocity (FPM) Velocity Pressure	400	500	600	700	800	900	1000
			0.032	0.048	0.070	0.092	0.120	0.140	0.160
8×4	0.166	CFM	66	83	99	116	132	149	166
		NC	<20	<20	<20	20	20-25	25	30-35
6×6	0.191	CFM	76	95	115	134	153	172	191
		NC	<20	<20	<20	20	20-25	25-30	30-35
10×4	0.210	CFM	84	105	126	147	168	189	210
		NC	<20	<20	<20	20-25	25	25-30	30-35
8×6	0.260	CFM	104	130	156	182	208	234	260
		NC	<20	<20	<20	20-25	25	25-30	30-35
10×6	0.329	CFM	132	165	198	231	264	296	329
		NC	<20	<20	<20	20-25	25-30	30	35
8×8	0.355	CFM	142	177	213	248	284	319	355
		NC	<20	<20	20-25	25	25-30	30	35
12×6	0.399	CFM	159	199	239	279	319	359	399
		NC	<20	<20	20-25	25	25-30	30-35	35
14×6	0.468	CFM	187	234	281	328	374	421	468
		NC	<20	<20	20-25	25	30	30-35	35-40
10×10	0.569	CFM	228	285	341	398	455	512	569
		NC	<20	<20	20-25	25-30	25-30	30-35	35-40
14×8	0.638	CFM	255	319	383	447	510	574	638
		NC	<20	<20	20-25	25-30	30-35	30-35	35-40
12×12	0.834	CFM	333	417	500	583	667	750	834
		NC	<20	<20	20-25	25-30	30-35	35	35-40
14×14	1.148	CFM	459	574	689	804	919	1034	1148
		NC	<20	20-25	25	25-30	30-35	35	35-40
20×10	1.167	CFM	467	583	700	817	934	1050	1167
		NC	<20	20-25	25-30	30	30-35	35-40	40
18×12	1.268	CFM	507	634	761	887	1014	1141	1268
		NC	<20	20-25	25-30	30	30-35	35-40	40
16×16	1.514	CFM	605	757	908	1060	1211	1362	1514
		NC	<20	20-25	25-30	30	35	35-40	40
24×12	1.702	CFM	681	851	1021	1191	1362	1532	1702
		NC	<20	20-25	25-30	30-35	35	35-40	>40
18×18	1.929	CFM	772	965	1158	1350	1543	1736	1929
		NC	<20	20-25	25-30	30-35	35	35-40	>40
30×12	2.136	CFM	855	1068	1282	1495	1709	1923	2136
		NC	<20	20-25	25-30	30-35	35	35-40	>40
20×20	2.395	CFM	958	1198	1437	1677	1916	2156	2395
		NC	<20	20-25	25-30	30-35	35	40	>40
24×20	2.886	CFM	1154	1443	1732	2020	2309	2597	2886
		NC	<20	25	30	30-35	35-40	40	>40
22×22	2.911	CFM	1165	1456	1747	2038	2329	2620	2911
		NC	<20	25	30	30-35	35-40	40	>40
30×18	3.251	CFM	1300	1625	1951	2276	2601	2926	3251
		NC	<20	25	30	35	35-40	40	>40
24×24	3.478	CFM	1391	1739	2087	2435	2782	3130	3478
		NC	<20	25-30	30	35	35-40	40	>40
30×20	3.622	CFM	1449	1811	2173	2536	2898	3260	3622
		NC	<20	25-30	30-35	35	35-40	40-45	>40
36×18	3.912	CFM	1565	1956	2347	2738	3129	3521	3912
		NC	<20	25-30	30-35	35	35-40	40-45	40-45
30×24	4.365	CFM	1746	2183	2619	3056	3492	3929	4365
		NC	20-25	25-30	30-35	35	35-40	40-45	>40
36×24	5.253	CFM	2101	2626	3152	3677	4202	4728	5253
		NC	20-25	25-30	30-35	35-40	35-40	40-45	45
30×30	5.480	CFM	2192	2740	3288	3836	4384	4932	5480
		NC	20-25	25-30	30-35	35-40	35-40	40-45	>45
36×30	6.594	CFM	2638	3297	3956	4616	5275	5935	6594
		NC	20-25	25-30	30-35	35-40	40	40-45	>45
48×24	7.028	CFM	2811	3514	4217	4919	5622	6325	7028
		NC	20-25	25-30	30-35	35-40	40-45	45	>45
36×36	7.935	CFM	3174	3968	4761	5555	6348	7142	7935
		NC	25	30	35	35-40	40-45	45	>45
48×36	10.616	CFM	4246	5308	6370	7431	8493	9554	10616
		NC	30-35	35-40	40-45	45-50	>50	50-55	>55
48×48	14.205	CFM	5682	7102	8523	9943	11364	12784	14205
		NC	35-40	40-45	50	50-55	>55	>55	>55

Performance Notes:

- 1 Additional performance data for sizes not listed is available at www.shoemakerfmg.com
- 2 Effective core areas listed in chart are defined as the measurement of space between the blades actually being utilized by the air
- 3 Data obtained from tests conducted in accordance with ANSI/ASHRAE standard 70-2006

FIXED BAR BLADE GRILLES

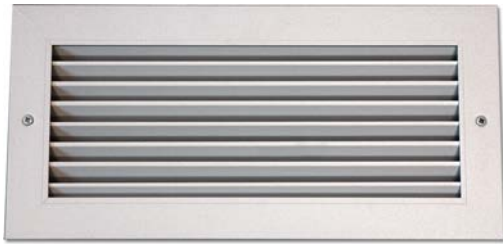

915 – Blades parallel to longest dimension



916 – Blades parallel to shortest dimension

915/916 Series Fixed Bar Blade Grille

Standard Features:

- Extruded aluminum surface mount frame with signature line marks
- Extruded aluminum fixed bar blades at 45°
 - 915 – Blades are parallel to longest dimension
 - 916 – Blades are parallel to shortest dimension
- Designed to minimize vision into air duct
- Center margins are mounted on the backside of the grille for a streamlined continuous look
- Countersunk mounting holes for flush appearance with color matching Phillips posi-drive screws
- Rust resistant pre-coat with durable powder finish
- Soft White

Options:

- Recessed screwdriver operated Opposed Blade Damper
MODEL: 915-0 / 916-0
- Heavy duty construction
- Insect screen
- Fractional, exact I.D. and O.D. sizes
- Square to round 2" collar with roll formed retention bead – available in square sizes only
- T-20 Tamper Proof Screws

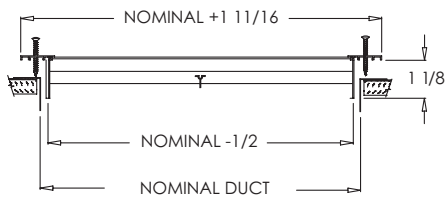

915

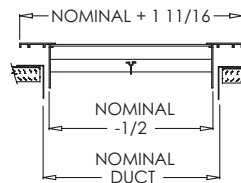

916

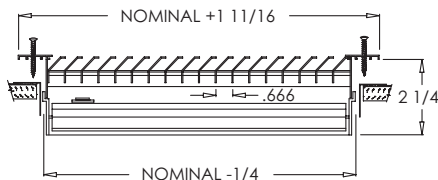

916-O

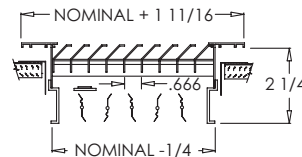

915-O

Performance Data: 915 Series

Duct Size	Core Eff. Area (ft ²)	Neck Velocity (FPM) Velocity Pressure	400	500	600	700	800	900	1000
			0.032	0.048	0.070	0.092	0.120	0.140	0.160
8×8	0.319	CFM	128	160	191	223	255	287	319
		NC	20-25	20-25	25	25-30	25-30	25-30	30
10×6	0.325	CFM	130	162	195	227	260	292	325
		NC	20-25	20-25	25	25-30	25-30	25-30	30
12×6	0.401	CFM	160	201	241	281	321	361	401
		NC	20-25	25	25-30	25-30	25-30	25-30	30
14×6	0.477	CFM	191	239	286	334	382	430	477
		NC	20-25	20-25	25-30	25-30	25-30	30	30-35
10×10	0.511	CFM	205	256	307	358	409	460	511
		NC	20-25	20-25	25	25-30	25-30	30	30-35
14×8	0.632	CFM	253	316	379	442	505	568	632
		NC	20-25	20-25	25-30	25-30	25-30	30	30-35
12×12	0.749	CFM	299	374	449	524	599	674	749
		NC	25	25-30	25-30	30	30-35	30-35	30-35
14×14	1.031	CFM	413	516	619	722	825	928	1031
		NC	20-25	25-30	25-30	30-35	30-35	30-35	35
20×10	1.171	CFM	468	586	703	820	937	1054	1171
		NC	25-30	25-30	30-35	30-35	30-35	35-40	35-40
16×16	1.359	CFM	544	679	815	951	1087	1223	1359
		NC	25-30	25-30	30-35	30-35	30-35	35-40	35-40
24×12	1.707	CFM	683	854	1024	1195	1366	1536	1707
		NC	25-30	30	30-35	30-35	30-35	35-40	35-40
18×18	1.732	CFM	693	866	1039	1212	1385	1559	1732
		NC	25-30	25-30	30-35	30-35	35	35-40	35-40
20×20	2.150	CFM	860	1075	1290	1505	1720	1935	2150
		NC	25-30	30-35	30-35	35	35-40	35-40	35-40
22×22	2.613	CFM	1045	1306	1568	1829	2090	2352	2613
		NC	30	30-35	30-35	35-40	35-40	35-40	40
24×20	2.691	CFM	1077	1346	1615	1884	2153	2422	2691
		NC	30	30-35	30-35	35-40	35-40	35-40	35-40
24×24	3.121	CFM	1248	1561	1873	2185	2497	2809	3121
		NC	30-35	30-35	35	35-40	35-40	35-40	40
30×18	3.190	CFM	1276	1595	1914	2233	2552	2871	3190
		NC	30-35	30-35	35	35-40	35-40	35-40	>40
30×20	3.504	CFM	1402	1752	2102	2453	2803	3154	3504
		NC	30-35	30-35	35	35-40	35-40	35-40	>40
36×18	3.919	CFM	1568	1960	2352	2743	3135	3527	3919
		NC	30-35	30-35	35-40	35-40	35-40	40	>40
30×24	4.100	CFM	1640	2050	2460	2870	3280	3690	4100
		NC	30-35	35	35-40	35-40	35-40	40	>40
30×30	4.917	CFM	1967	2458	2950	3442	3933	4425	4917
		NC	30-35	35	35-40	35-40	35-40	40	>40
36×24	5.079	CFM	2032	2540	3048	3556	4064	4571	5079
		NC	30-35	35	35-40	35-40	35-40	40	>40
36×30	6.146	CFM	2458	3073	3688	4302	4917	5531	6146
		NC	30-35	35	35-40	35-40	40	>40	>40
48×24	7.038	CFM	2815	3519	4223	4926	5630	6334	7038
		NC	35	35-40	35-40	35-40	40	40-45	40-45
36×36	7.118	CFM	2847	3559	4271	4983	5695	6407	7118
		NC	35	35-40	35-40	40	40-45	40-45	40-45
48×36	10.077	CFM	4031	5038	6046	7054	8061	9069	10077
		NC	35-40	35-40	40	40-45	40-45	40-45	45
48×48	12.741	CFM	5096	6370	7645	8919	10193	11467	12741
		NC	30-40	35-40	40-45	40-45	45	<50	<50

Performance Notes:

- 1 Additional performance data for sizes not listed is available at www.shoemakerfmfg.com
- 2 Effective core areas listed in chart are defined as the measurement of space between the blades actually being utilized by the air
- 3 Data obtained from tests conducted in accordance with ANSI/ASHRAE standard 70-2006



Field Adjustable



High Capacity



MRI Compatible



Multi-Family



Expedited Service



Extended Leadtime

SILL GRILLES

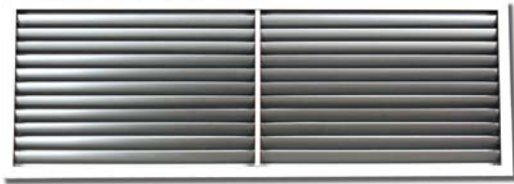

1000R



1000S

1000 Series Sill Grilles

Standard Features:

- Extruded aluminum surface mount frame with signature line marks
- Narrow 5/8" frame for clean appearance
- 1000R: 45° fixed blades parallel to longest dimension with 2/3" spacing return air grille
- 1000S: 15° fixed blades parallel to longest dimension with 1/3" pencil proof spacing grille
- Satin Anodized

Options:

- Recessed screwdriver operated Opposed Blade Damper
MODEL: 1000R-O / 1000S-O
- Drywall Flange – 9/16" depth
MODEL: 1000R-DW / 1000S-DW
- Blades run parallel to shortest dimension
- Countersunk mounting holes for flush appearance with color matching screws

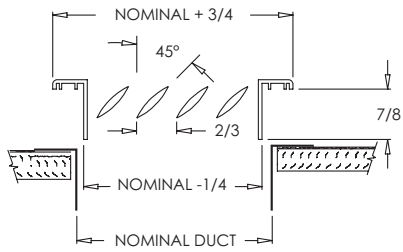

1000R

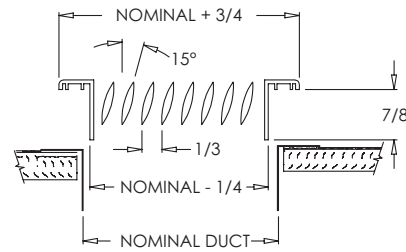

1000S

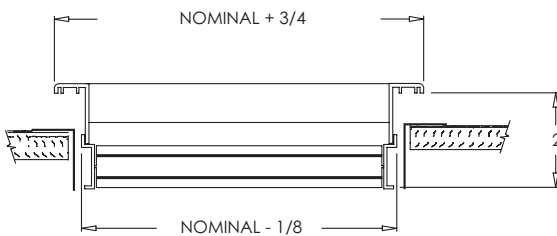

1000R-O

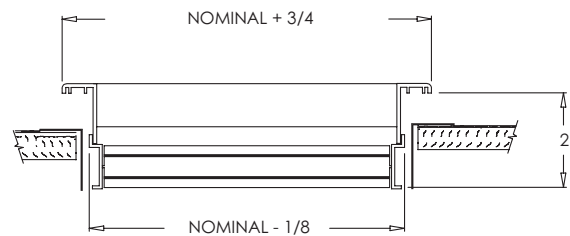

1000S-O

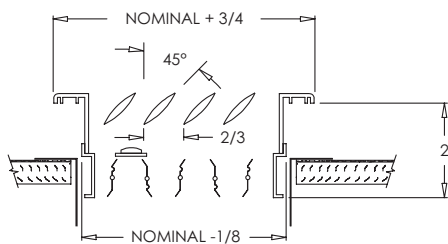

1000R-O

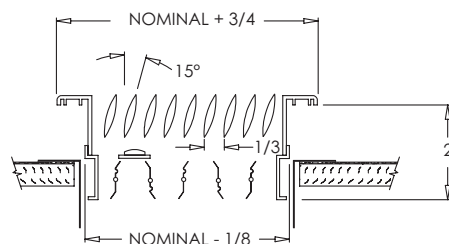

1000S-O

Performance Data: 1000R Return Series

Duct Size	Core Eff. Area (ft ²)	Neck Velocity (FPM) Velocity Pressure	300	400	500	600	700	800	900	1000
			0.006	0.010	0.015	0.021	0.029	0.038	0.048	0.065
1 1/2"	0.068	CFM	21	27	34	41	48	55	62	68
2"	0.107	CFM	32	43	54	64	75	86	97	107
2 1/2"	0.142	CFM	42	57	71	85	99	113	127	142
3"	0.181	CFM	54	72	90	108	126	145	163	181
3 1/2"	0.215	CFM	64	86	107	129	150	172	193	215
4"	0.249	CFM	75	100	125	149	174	199	224	249
5"	0.317	CFM	95	127	159	190	222	254	286	317
6"	0.391	CFM	117	156	195	234	273	313	352	391
8"	0.532	CFM	160	213	266	319	373	426	479	532
10"	0.674	CFM	202	270	337	404	472	539	606	674

Performance Notes:

1 All values in above table are per lineal foot

2 Effective core areas listed in chart are defined as the measurement of space between the blades actually being utilized by the air

3 Data obtained from tests conducted in accordance with ANSI/ASHRAE standard 70-2006

Performance Data: 1000S Supply Series

Duct Size	Core Eff. Area (ft ²)	Neck Velocity (FPM) Velocity Pressure	300	400	500	600	700	800	900	1000
			0.006	0.010	0.015	0.021	0.029	0.038	0.048	0.065
1 1/2"	0.054	CFM (ft.)	16	21	27	32	38	43	48	54
		NC	<20	<20	<20	20	25	25-30	30-35	35
		Throw	1 2 2 2 2.5 3.5 3 3.5 4.5 3 4 5 4 5 7 5 6 8 5 6.5 9.5 6 7 9 11							
2"	0.093	CFM/ft	28	37	46	56	65	74	83	93
		NC	<20	<20	<20	20	25	25-30	30-35	35
		Throw	2 3 4 3 3.5 4.5 4 4 5.5 6.5 4 5.5 7.5 5 7 9 6 8 11 6.5 8 12 7 9 14							
2 1/2"	0.122	CFM/ft	37	49	61	73	85	98	110	122
		NC	<20	<20	20	20	25	25-30	30-35	35
		Throw	3 3.5 4.5 3.5 4.5 5.5 5 6.5 7.5 5.5 7 9 6 7.5 10.5 7 8.5 11.5 8 9.5 14.5 9 10.5 16							
3"	0.161	CFM/ft	48	64	81	97	113	129	145	161
		NC	<20	<20	20	20	25	25-30	30-35	35
		Throw	4 4.5 5.5 4 5.5 6.5 6 7 9 6 7.5 10.5 7 8.5 11.5 8 10 14 9 10.5 16 10 12 18							
3 1/2"	0.190	CFM/ft	57	76	95	114	133	152	171	190
		NC	<20	<20	20	20	25	25-30	35	35-40
		Throw	4 4.5 5.5 5 6.5 7.5 7 8 10 6.5 7.5 10.5 8 9.5 12.5 9.5 11 15 10 12 18 11 13 19							
4"	0.220	CFM/ft	66	88	110	132	154	176	198	220
		NC	<20	<20	20	20	25	30	35	35-40
		Throw	4 4.5 5.5 5.5 6.5 7.5 7.5 8 10 8 9.5 12.5 9 11 15 11 13 17 11 13.5 20 13 14.5 22							
5"	0.278	CFM/ft	83	111	139	167	195	223	250	278
		NC	<20	<20	20	25	25-30	30	35	35-40
		Throw	5 5.5 6.5 6 7 9 8 9 11 9 11 15 10 12 16 12 13.5 18 12 14.5 22 14 15 22							
6"	0.347	CFM/ft	104	139	173	208	243	277	312	347
		NC	<20	<20	20	25	25-30	30	35	40
		Throw	5.5 6.5 7.5 7 8 10 9 11 13 9 11 15 11 13 17 13 14.5 20 13 15 23 15 17 25							
8"	0.474	CFM/ft	142	189	237	284	332	379	426	474
		NC	<20	<20	20	25	25-30	35	35-40	40
		Throw	6 7 9 8 10 12 10 11.5 14.5 11 13 17 12 14 17 14 16 22 14 17 25 17 20 30							
10"	0.601	CFM/ft	180	240	300	360	420	480	541	601
		NC	<20	20	25	25-30	30	35	35-40	40
		Throw	7 9 11 9 10 12 11 13.5 17 12 14.5 20 14 16 22 15 18 24 16 20 30 20 24 36							

Performance Notes:

1 All values in above table are per lineal foot

2 Throw values are measured in feet for terminal velocities of 150/100/50 FPM

3 Throw data is based on supply air and room air both at isothermal conditions

4 Effective core areas listed in chart are defined as the measurement of space between the blades actually being utilized by the air

5 Data obtained from tests conducted in accordance with ANSI/ASHRAE standard 70-2006



Field Adjustable



High Capacity



MRI Compatible



Multi-Family



Expedited Service



Extended Leadtime

ADJUSTABLE CEILING AND SIDEWALL DIFFUSERS

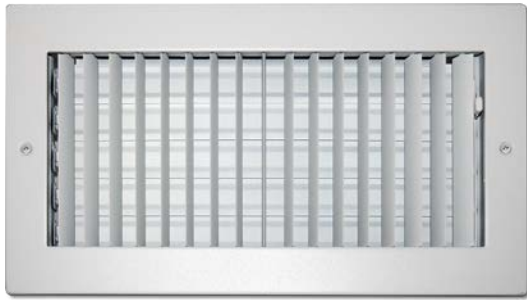

950 Series Adjustable Blade Diffuser

Standard Features:

- Adjustable aluminum airfoil blades oriented for 1 or 2 way airflow pattern
- Blades parallel to shortest dimension
- One piece stamped steel frame on most common sizes, alternate frame is extruded aluminum with signature line marks. Visit www.shoemakerimg.com for size and frame style availability.
- Lever operated steel multi-shutter damper
- Designed for ceiling or sidewall applications
- Nylon bushings on adj. blades prevent metal on metal rattle
- Countersunk mounting holes for flush appearance with color matching Phillips posi-drive screws
- Rust resistant pre-coat with durable powder finish
- Soft White

Options:

- Lever operated Opposed Blade Damper
MODEL: 950-0
- Adjustable steel roll formed blades
MODEL: 951
- T-20 Tamper Proof Screws

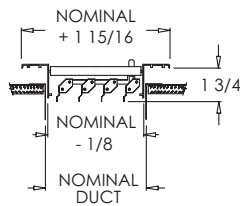

950/951 (Extruded Aluminum Frame)

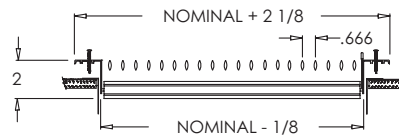

950/951 (Extruded Aluminum Frame)

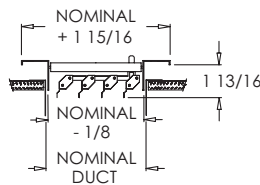

950/951 (Stamped Steel One Piece Frame)

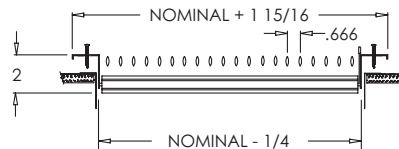

950/951 (Stamped Steel One Piece Frame)

Performance Data: 950/951 Series

Duct Size	Core Eff. Area (ft ²)	Neck Velocity (FPM)		400		500		600		700		800		1000		1200		1400						
		Velocity	Pressure	0.011	0.017	0.024	0.034	0.044	0.055	0.068	0.100													
8x4	0.157	CFM	63																					
		NC	20																					
		Throw	3	4	6	5	7	9	7	8.5	11.5	9	10	14	10	11	15	12	13.5	20	14	16	24	17
6x6	0.177	CFM	71																					
		NC	20																					
		Throw	3	4.5	7.5	6	8	10	8	9.5	13	9	10.5	14.5	11	12.5	17	13	14	21	15	17	27	19
10x4	0.199	CFM	80																					
		NC	20																					
		Throw	4	5	8	7	9	11	9	10	14	10	11	15	12	13.5	18	14	15	21	15	17	25	20
12x4	0.241	CFM	96																					
		NC	20																					
		Throw	4	5.5	8.5	7	9	11	9	10	14	12	13	17	14	14.5	20	14	14.5	22	16	18	26	21
8x6	0.247	CFM	99																					
		NC	20																					
		Throw	5	6	8	8	9	11	9	10	14	12	13	17	14	15	20	14	14.5	22	16	18	26	21
14x4	0.283	CFM	113																					
		NC	20																					
		Throw	5	6.5	8	9	10	12	10	11	15	13	13.5	18	15	16	21	14	15	23	17	19	29	22
10x6	0.313	CFM	125																					
		NC	20																					
		Throw	6	7	9	10	11	13	12	13	17	13	14.5	20	16	17	23	18	20	30	21	24	36	25
8x8	0.337	CFM	135																					
		NC	20																					
		Throw	6	7.5	9	10	11	13.5	13	14	18	14	16	21	16	18	24	19	21	31	22	25	37	26
12x6	0.379	CFM	151																					
		NC	20																					
		Throw	7	8	10	11	11.5	14.5	13	14	18	14	16	21	16	17	24	20	22	32	23	26	38	27
14x6	0.444	CFM	178																					
		NC	20																					
		Throw	8	9	11	12	13.5	17	15	16	20	15	17	23	18	20	27	22	24	35	25	28	41	29
24x4 16x6	0.510	CFM	204																					
		NC	20																					
		Throw	9	10	12	12	13.5	17	15	16	21	15	17	24	18	20	28	22	24	36	26	29	42	30
12x8	0.516	CFM	207																					
		NC	20																					
		Throw	10	11	13	13	15	19	15	16	21	15	17	24	18	20	28	22	24	36	27	30	44	31
10x10	0.541	CFM	216																					
		NC	20																					
		Throw	11	12	14	14	16	20	15	16	22	15	17	24	18	20	28	22	24	36	27	30	44	32
14x8	0.606	CFM	242																					
		NC	20																					
		Throw	12	13	15	14	16	20	16	17	23	17	19	26	20	22	31	23	26	39	28	32	47	34
14x10 18x8	0.785	CFM	314																					
		NC	20																					
		Throw	13	14	18	15	17	21	18	20	26	20	22	31	23	26	36	27	31	46	31	35	53	35
12x12	0.792	CFM	317																					
		NC	20																					
		Throw	14	15	18	15	17	21	18	20	27	20	22	31	23	26	36	27	31	47	32	36	54	36
20x8	0.875	CFM	350																					
		NC	20																					
		Throw	15	16	19	16	18	22	18	20	28	21	23	32	24	27	37	28	32	48	33	37	55	37
14x14	1.091	CFM	436																					
		NC	20																					
		Throw	17	19	20	17	19	23	19	21	29	22	24	34	25	29	39	30	34	50	34	39	57	38

Performance Notes:

- 1 Performance data calculated with blades set at 0°
- 2 Additional performance data for sizes not listed is available at www.shoemakerfmg.com
- 3 Throw values are measured in feet for terminal velocities of 150/100/50 FPM
- 4 Throw data is based on supply air and room air both at isothermal conditions
- 5 Effective core areas listed in chart are defined as the measurement of space between the blades actually being utilized by the air
- 6 Data obtained from tests conducted in accordance with ANSI/ASHRAE standard 70-2006

ADJUSTABLE CEILING AND SIDEWALL DIFFUSERS



945 Series Adjustable Blade 3 or 4-way Diffuser

Standard Features:

- Adjustable blades oriented for 3 or 4-way air flow pattern
- One piece stamped steel frame on most common sizes, alternate frame is extruded aluminum with signature line marks. Visit www.shoemakermg.com for size and frame style availability.
- Designed for ceiling or sidewall applications
- Nylon bushings on adj. blades prevent metal on metal rattle
- Countersunk mounting holes for flush appearance with color matching Phillips posi-drive screws
- Rust resistant pre-coat with durable powder finish
- Soft White

Options:

- Lever operated Opposed Blade Damper
MODEL: 945-0
- T-20 Tamper Proof Screws

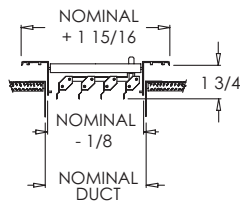

945 (Extruded Aluminum Frame)

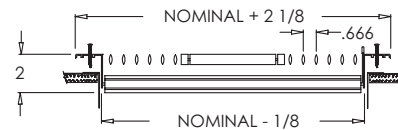

945 (Extruded Aluminum Frame)

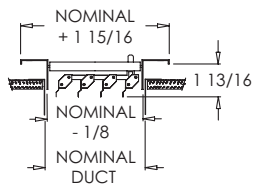

945 (Stamped Steel One Piece Frame)

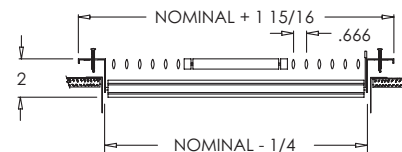

945 (Stamped Steel One Piece Frame)

Performance Data: 945 Series

Duct Size	Core Eff. Area (ft ²)	Neck Velocity (FPM)		Velocity Pressure																									
		300	400	500	600	700	800	900	1000	1200	0.007	0.011	0.017	0.024	0.034	0.044	0.055	0.068	0.100										
8x4	0.140	CFM	42	56	70	84	98	112	126	140	168																		
		NC	<20	20	25	25	30	30	35	35	40																		
		Throw C	4	5	6	6	6.5	8	8	9	10.5	9	10.5	13.5	9	11	16	12	13.5	18	12	15	22	13	16	23	16	20	28
		Throw S	3	4	5	3	4	5	3	4	5	3	4	5	4	4.5	6	4	5	7	4	5	7	4	6	9	6	7.5	12
		CFM	52	70	87	105	122	140	157	175	210																		
10x4	0.175	NC	<20	20	25	25	30	30	35	35	40																		
		Throw C	4	5	6	6	6.5	8	8	9	10.5	9	10.5	13.5	10	12	17	12	14	19	13	16	23	13	16	23	16	20	28
		Throw S	2	3	3	3	4	5	4	5	7	5	6.5	9	6	6.5	10	6	7.5	10.5	6	8	12	7	9	13	8	10	15
		CFM	66	88	110	132	154	175	197	219	263																		
		NC	<20	20	25	25	30	35	35	40	40																		
12x4	0.219	Throw C	5	6	7.5	7	8	10	10	10.5	13	9	11	16	12	13.5	18	12	15	21	14	17	24	14	17	26	17	21	31
		Throw S	4	4	5	5	4.5	5.5	4	5	7	5	6.5	9	7	7.5	10.5	7	9	12	8	10	14	9	10.5	17	10	12	18
		CFM	81	107	134	161	188	215	242	268	322																		
		NC	<20	20	25	25	30	35	35	40	40																		
		Throw C	4	6	7.5	7	8	10	10	10.5	13	9	11	16	12	13.5	18	12	15	21	14	17	24	15	18	27	18	22	33
14x4	0.268	Throw S	4	4	5	4	5	7	6	7	8	6	7.5	10.5	8	9	12	9	10.5	13.5	9	10.5	17	10	12	18	11	14	22
		CFM	82	109	136	163	190	218	245	272	327																		
		NC	<20	20	25	25	30	35	35	40	40																		
		Throw C	6	7	8	9	10	11	11	13	14	11	13.5	18	13	15	21	15	18	24	16	20	29	17	21	30	20	24	34
		Throw S	4	4	5	4	5	7	6	7	8	6	7.5	10.5	8	9	12	9	10.5	13.5	9	11	17	11	13.5	20	13	16	23
10x6	0.272	CFM	105	140	175	210	244	279	314	349	419																		
		NC	<20	20	25	30	35	35	40	40																			
		Throw C	7	8	9	9	10	11	11	12	15	11	13	17	13	15	21	15	18	24	15	19	29	18	22	32	21	26	36
		Throw S	4	5	6	6	7	8	8	9	10.5	10	11.5	13.5	9	11	16	11	13	17	11	13.5	23	13	16	23	15	18	27
		CFM	121	161	202	242	283	323	363	404	484																		
12x6	0.349	NC	<20	20	25	30	35	35	40	40																			
		Throw C	7	8	10	10	10.5	13.5	12	13.5	17	13	15	21	15	18	24	16	20	27	17	22	33	20	24	36	24	29	44
		Throw S	6	7	8	7	8	10	9	10	13	9	10.5	13.5	10	12	17	12	14	19	12	15	23	14	17	26	16	20	30
		CFM	143	190	238	286	333	381	429	476	571																		
		NC	<20	20	25	30	35	35	40	40	45																		
14x6	0.404	Throw C	7	9	10	18	10.5	13.5	12	13.5	17	13	15	21	15	18	24	17	21	29	18	23	33	21	26	38	25	30	45
		Throw S	6	8	9	7	8	10	9	10.5	13.5	10	12	17	12	14	18	13	16	22	14	17	26	15	18	27	19	23	35
		CFM	162	216	271	325	379	433	487	541	649																		
		NC	<20	20	25	30	35	40	40	45	45																		
		Throw C	8	9	11	11	13	16	15	17	22	16	18	24	17	21	29	20	24	33	21	26	39	24	29	44	27	33	51
12x8	0.476	Throw S	7	8	9	9	10	11	10	11	14	11	13	17	13	15	21	14	17	23	15	18	27	16	20	30	20	24	36
		CFM	219	291	364	437	510	583	656	729	874																		
		NC	20	20	25	30	35	40	40	45	45																		
		Throw C	10	12	14	13	15	18	18	20	25	18	21	27	20	24	34	23	28	39	24	30	45	28	35	50	32	39	57
		Throw S	9	10	12	11	12	13	12	14	17	14	16	20	15	18	26	17	21	29	17	22	33	21	26	36	25	30	42
14x8	0.541	CFM	162	216	271	325	379	433	487	541	649																		
		NC	<20	20	25	30	35	40	40	45	45																		
		Throw C	8	9	11	11	13	16	15	17	22	16	18	24	17	21	29	20	24	33	21	26	39	24	29	44	27	33	51
		Throw S	7	8	9	9	10	11	10	11	14	11	13	17	13	15	21	14	17	23	15	18	27	16	20	30	20	24	36
		CFM	219	291	364	437	510	583	656	729	874																		
14x10	0.729	NC	20	20	25	30	35	40	40	45	45																		
		Throw C	10	12	14	13	15	18	18	20	25	18	21	27	20	24	34	23	28	39	24	30	45	28	35	50	32	39	57
		Throw S	9	10	12	11	12	13	12	14	17	14	16	20	15	18	26	17	21	29	17	22	33	21	26	36	25	30	42
		CFM	219	291	364	437	510	583	656	729	874																		
		NC	20	20	25	30	35	40	40	45	45																		

Performance Notes:

- Performance data calculated with blades set at 0°
- Additional performance data for sizes not listed is available at www.shoemakermfg.com
- Throw values are measured in feet for terminal velocities of 150/100/50 FPM
- Throw data is based on supply air and room air both at isothermal conditions
- Effective core areas listed in chart are defined as the measurement of space between the blades actually being utilized by the air
- Data obtained from tests conducted in accordance with ANSI/ASHRAE standard 70-2006

PERFORATED DIFFUSER

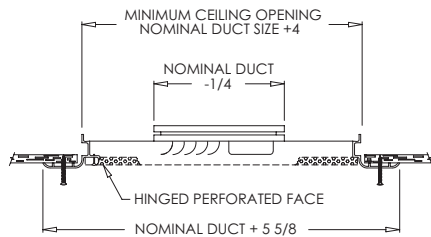
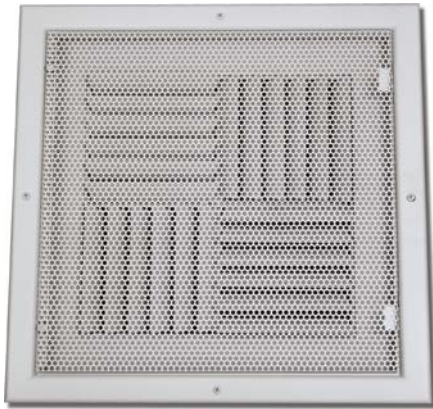

500MA
(dimensions for 500CB are the same as above)

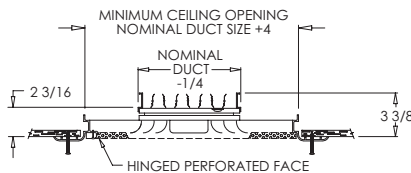

500CB-O
(dimensions for 500MA-O are the same as above)

500 Series Perforated Curved Blade Surface Mount Diffuser

Standard Features:

- Modular core (500MA) or adjustable curved blade (500CB) diffuser
- Nylon bushings on adj. blades prevent metal on metal rattle (500CB)
- Extruded aluminum surface mount frame with signature line marks
- Hinged perforated face with screwdriver access to release
- 3/16" holes on 1/4" staggered centers
- Square Collar
- Countersunk mounting holes for flush appearance with color matching Philips posi-drive screws
- Ceiling opening must be 4" larger in length and width than the nominal duct size
- Rust resistant pre-coat with durable powder finish
- Soft White

Options:

- Moveable modular cores
MODEL: 500MA
- Adjustable curved blade diffuser
MODEL: 500CB
- Recessed screwdriver operated Opposed Blade Damper
MODEL: 500MA-O or 500CB-O
- 2" ADC compliant round collar with bead for ease of installation
- T-20 Tamper Proof Screws



Performance Data: 500MA Series

Duct Size	Core Eff. Area (ft ²)	Neck Velocity (FPM) Velocity Pressure	300	400	500	600	700	800	900	1000
			0.007	0.011	0.017	0.024	0.032	0.044	0.056	0.067
6×6	0.106	CFM	32	43	53	64	74	85	96	106
		NC	<20	<20	<20	<20	<20	20	20	25
		Throw	1 2 4	2 3 5	3 4 6	4 5 8	5 6 10	6 8 12	7 9 13	8 10 15
8×8	0.200	CFM	60	80	100	120	140	160	180	200
		NC	<20	<20	<20	<20	<20	20	20	25
		Throw	2 3 5	3 4 6	4 5 7	5 6 8	6 8 10	7 9 13	8 10 14	9 11 17
10×10	0.323	CFM	97	129	162	194	226	259	291	323
		NC	<20	<20	<20	20	20	20	25	25-30
		Throw	3 4 6	4 5 7	5 6.5 9.5	7 9 13	8 10 15	10 12 18	11 14 21	13 16 24
12×12	0.476	CFM	143	190	238	286	333	381	429	476
		NC	<20	<20	<20	20	20	20	25	25-30
		Throw	4 5 7	5 6 9	7 8 12	8 10 15	10 12 18	11 13 19	12 15 22	15 18 26
14×14	0.658	CFM	198	263	329	395	461	527	593	658
		NC	<20	<20	<20	20	20	25	25-30	25-30
		Throw	5 6 8	6 7 11	8 9 13	10 12 17	11 13 19	12 15 22	14 17 25	16 19 29
16×16	0.870	CFM	261	348	435	522	609	696	783	870
		NC	<20	<20	<20	20	25	25-30	30	30-35
		Throw	6 7 9	7 8 12	9 10 15	11 13 18	12 14 21	13 16 24	15 18 27	17 20 30

Performance Notes:

- 1 Additional performance data for sizes not listed is available at www.shoemakermfg.com
- 2 Throw values are measured in feet for terminal velocities of 150/100/50 FPM
- 3 Throw data is based on supply air and room air both at isothermal conditions
- 4 Effective core areas listed in chart are defined as the measurement of space between the blades actually being utilized by the air

PERFORATED RETURN AIR GRILLE

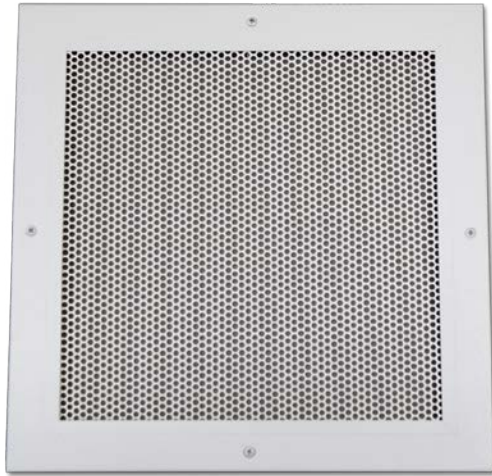

600P Series Perforated Return Air Grille

Standard Features:

- 3/16" holes on 1/4" staggered centers
- Extruded aluminum frame with signature line marks
- Perforated material 58% free area
- Countersunk mounting holes for flush appearance with color matching Phillips posi-drive screws
- Rust resistant pre-coat with durable powder finish
- Soft White

Options:

- Recessed screwdriver operated Opposed Blade Damper
MODEL: 600P-0
- Insect screen
- 2" ADC compliant round collar with bead for ease of installation – available in square sizes only
- T-20 Tamper Proof Screws

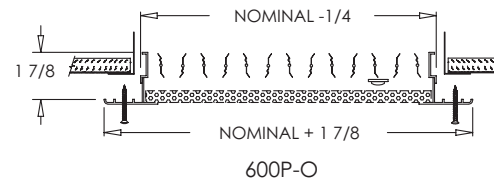
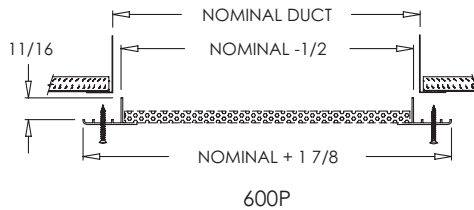

Performance Data: 600P Series

Duct Size	Core Eff. Area (ft ²)	Neck Velocity (FPM) Velocity Pressure	300	400	500	600	700	800	900	1000	1200
			0.032	0.048	0.070	0.092	0.120	0.140	0.160	0.182	0.204
6×6	0.111	CFM	33	45	56	67	78	89	100	111	134
		NC	20	25-30	30	30-35	30-35	30-35	35	35-40	40
8×8	0.207	CFM	62	83	104	124	145	166	186	207	248
		NC	20-25	25-30	30	30-35	30-35	30-35	35	35-40	40
10×10	0.332	CFM	100	133	166	199	233	266	299	332	399
		NC	20-25	25-30	30	35	35	35	40	40-45	45
12×12	0.487	CFM	146	195	243	292	341	389	438	487	584
		NC	20-25	25-30	30	35	35	35-40	40	40-45	45
14×14	0.671	CFM	201	268	335	402	470	537	604	671	805
		NC	20-25	30	30	35	35	40	40	40-45	>45
16×16	0.884	CFM	265	354	442	531	619	707	796	884	1061
		NC	20-25	30	35	35	40	40	40	45	>45
18×18	1.127	CFM	338	451	564	676	789	902	1014	1127	1353
		NC	20-25	30	35	35	40	40	40-45	45	>45
20×20	1.400	CFM	420	560	700	840	980	1120	1260	1400	1679
		NC	20-25	30	35	35	40	40	40-45	45	>45
24×24	2.033	CFM	610	813	1016	1220	1423	1626	1829	2033	2439
		NC	20-25	30	35	40	40	40	40-45	>45	>45

Performance Notes:

1 Additional performance data for sizes not listed is available at www.shoemakerfmg.com

2 Effective core areas listed in chart are defined as the measurement of space between the blades actually being utilized by the air

3 Data obtained from tests conducted in accordance with ANSI/ASHRAE standard 70-2006

LATTICE RETURN AIR GRILLE

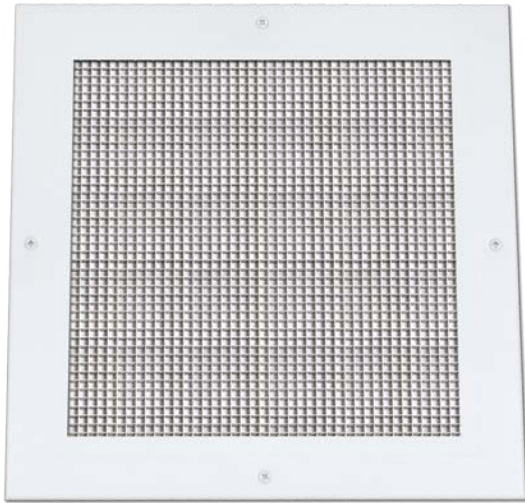

600 Series Lattice Return Air Grille

Standard Features:

- 1/2" × 1/2" × 1/2" Aluminum lattice surface mount grille
- Extruded aluminum frame with signature line marks
- Lattice material 90% free area
- Countersunk mounting holes for flush appearance with color matching Phillips posi-drive screws
- Rust resistant pre-coat with durable powder finish
- Soft White

Options:

- Recessed screwdriver operated Opposed Blade Damper
MODEL: 600-0
- 1/2" × 1/2" × 1/2" 45° sightproof aluminum lattice, deflection parallel to longest dimension
MODEL: 645
- 1/2" × 1/2" × 1/2" 45° sightproof aluminum lattice, deflection parallel to shortest dimension
MODEL: 646
- 1" × 1" × 1" Lattice
- 1/2" × 1/2" × 1" Lattice
- Continuous lengths with butt joints
- Fractional, exact I.D. and O.D. sizes
- Insect screen
- 2" ADC compliant round collar with bead for ease of installation – available in square sizes only
- T-20 Tamper Proof Screws

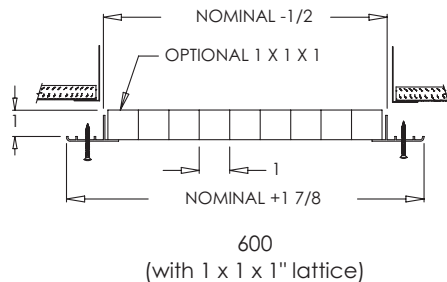
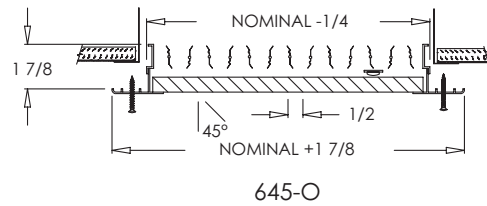
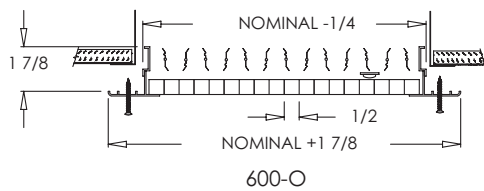
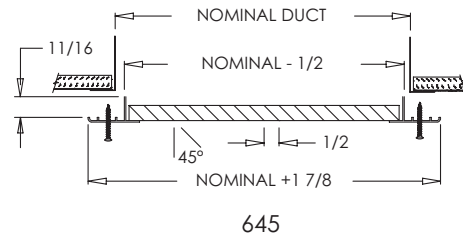
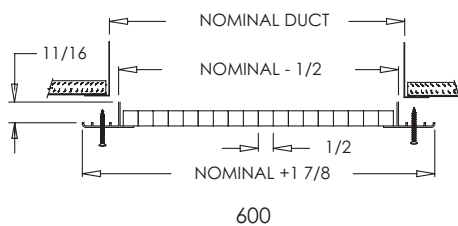

Performance Data: 600 Series

Duct Size	Core Eff. Area (ft ²)	Neck Velocity (FPM) Velocity Pressure	400	500	600	700	800	1000	1200
			0.032	0.048	0.070	0.092	0.120	0.140	0.160
6×6	0.189	CFM	76	95	113	132	151	189	227
		NC	<20	<20	<20	<20	20-25	25-30	25-30
8×8	0.352	CFM	141	176	211	246	281	352	422
		NC	<20	20-25	20-25	25-30	25-30	30	30
14×6	0.464	CFM	186	232	278	325	371	464	557
		NC	<20	25	25-30	25-30	30	30	35
10×10	0.564	CFM	226	282	338	395	451	564	677
		NC	<20	25	25-30	25-30	30	30	35
12×12	0.827	CFM	331	413	496	579	661	827	992
		NC	<20	25	25-30	25-30	30	30	35
14×14	1.139	CFM	456	570	683	797	911	1139	1367
		NC	<20	25	25-30	25-30	30	30	35
16×16	1.502	CFM	601	751	901	1051	1201	1502	1802
		NC	<20	25	25-30	25-30	30	30	35
24×12	1.689	CFM	676	845	1013	1182	1351	1689	2027
		NC	<20	25	25-30	25-30	30	30	35
18×18	1.914	CFM	766	957	1148	1340	1531	1914	2297
		NC	<20	25	25-30	25-30	30	30	35
30×12	2.120	CFM	848	1060	1272	1484	1696	2120	2544
		NC	<20	25	25-30	25-30	30	30	35
20×20	2.377	CFM	951	1188	1426	1664	1901	2377	2852
		NC	<20	25	25-30	25-30	30	30	35
36×12	2.552	CFM	1021	1276	1531	1786	2041	2552	3062
		NC	<20	25	25-30	25-30	30	30	35
22×22	2.889	CFM	1156	1445	1733	2022	2311	2889	3467
		NC	20	25	25-30	25-30	30	35	40
18×30	3.227	CFM	1291	1613	1936	2259	2581	3227	3872
		NC	20	25	25-30	25-30	30	35	40
24×24	3.452	CFM	1381	1726	2071	2416	2761	3452	4142
		NC	20	25	25-30	25-30	30	35	40
30×20	3.595	CFM	1438	1798	2157	2517	2876	3595	4314
		NC	20	25	25-30	25-30	35	35	40
30×24	4.333	CFM	1733	2166	2600	3033	3466	4333	5199
		NC	20	25	25-30	25-30	35	35	40
36×24	5.214	CFM	2086	2607	3128	3650	4171	5214	6257
		NC	20	25	25-30	25-30	35	40	45
30×30	5.439	CFM	2176	2720	3263	3807	4351	5439	6527
		NC	20	25	25-30	25-30	35	40	45
36×36	7.877	CFM	3151	3938	4726	5514	6301	7877	9452
		NC	20	25	30	35	35	40	45
48×48	14.102	CFM	5641	7051	8461	9871	11281	14102	16922
		NC	20	25	30	35	35	40	45

Performance Notes:

1 Additional performance data for sizes not listed is available at www.shoemakerfmg.com

2 Effective core areas listed in chart are defined as the measurement of space between the blades actually being utilized by the air

3 Data obtained from tests conducted in accordance with ANSI/ASHRAE standard 70-2006



Field Adjustable



High Capacity



MRI Compatible



Multi-Family



Expedited Service



Extended Leadtime

LOUVERED CEILING DIFFUSERS



100 Series Step Down Ceiling Diffuser

Standard Features:

- Step down core designed for 4-way uniform air distribution
- Countersunk mounting holes for flush appearance with color matching Phillips posi-drive screws
- Rust resistant pre-coat with durable powder finish
- Soft White

Options:

- Lever operated Multi-Shutter Damper
MODEL: 100-D
- Lever operated Opposed Blade Damper
MODEL: 100-O
- 2" ADC compliant round collar with bead for ease of installation
- T-20 Tamper Proof Screws

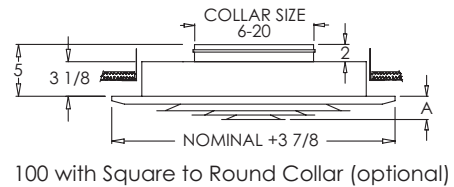
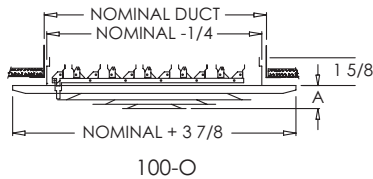
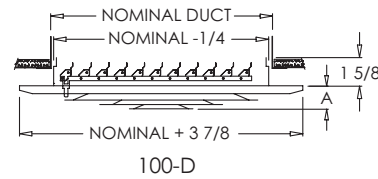
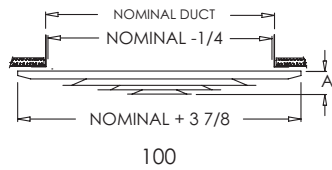

100 Series Dimensions

Size	6×6	8×8	10×10	12×12	14×14	16×16	18×18	20×20	24×24
Dimension (A)	1 1/4"	1 1/4"	1 5/8"	2"	2 1/4"	2 3/4"	3"	3"	3 1/4"

* A dimension is defined in product drawing

Performance Data: 100 Series

Duct Size	Core Eff. Area (ft ²)	Neck Velocity (FPM) Velocity Pressure	300	400	500	600	700	800	900	1000	1200
			0.007	0.011	0.017	0.024	0.034	0.044	0.055	0.068	0.100
6×6	0.138	CFM	41	55	69	83	96	110	124	138	165
		NC	<20	20	25	30	30	30	35	35	40
		Throw	2 3 5 4 4.5 5.5 5 5.5 6.5 5 6 8 6 7 9.5 7 8 11 8 9 13 8 9.5 14.5 9 11 15.5								
8×8	0.250	CFM	75	100	125	150	175	200	225	250	300
		NC	<20	20	25	30	30	30	35	35	40
		Throw	3 4.5 6 5 5.5 6.5 6 7 8.5 7 8 10.5 8 9.5 12.5 9 10 14 9 11 16 10 12 18 11 13 19								
10×10	0.396	CFM	119	158	198	238	277	317	356	396	475
		NC	<20	20	25	30	30	30	35	35	40
		Throw	4 5 6 6 6.5 7.5 7 8 9.5 8 9.5 11.5 9 10 14 10 12 16 11 13 19 12 14 20 13 15 23								
12×12	0.575	CFM	173	230	288	345	403	460	518	575	690
		NC	<20	25	30	30	30	30	35	35	40
		Throw	4 5.5 6.5 7 8 10 8 9.5 11.5 9 11 14 10 12 16 12 14 18 13 15 22 14 16 24 15 17 25								
14×14	0.788	CFM	236	315	394	473	551	630	709	788	945
		NC	<20	25	30	30	30	30	35	35	40
		Throw	5 6 8 7 8.5 10.5 8 11 13 11 13 17 13 15 20 14 16 22 15 17 25 16 19 29 18 21 31								
16×16	1.034	CFM	310	413	517	620	724	827	930	1034	1240
		NC	<20	25	30	30	30	30	35	35	40
		Throw	6 7 9 8 9.5 11.5 10 12 14.5 12 14 19 14 16 22 16 18 24 16 18 28 19 22 32 20 24 36								
18×18	1.313	CFM	394	525	656	788	919	1050	1181	1313	1575
		NC	20	25	30	30	35	35	35	40	40
		Throw	7 8 10 9 10 12.5 12 14 17 14 16 21 16 18 24 17 20 28 19 22 32 20 24 36 22 26 40								
20×20	1.625	CFM	488	650	813	975	1138	1300	1463	1625	1950
		NC	20	25	30	30	35	35	35	40	40
		Throw	8 9 11 10 12 14.5 14 16 19 15 17 22 17 20 27 20 23 31 21 24 35 22 26 40 24 29 43								
24×24	2.350	CFM	705	940	1175	1410	1645	1880	2115	2350	2820
		NC	20	25	30	30	35	35	40	40	40
		Throw	8 10 12.5 12 14 17 16 18 22 17 20 27 20 24 32 23 27 37 24 28 42 25 30 46 26 32 48								

Performance Notes:

- 1 Additional performance data for sizes not listed is available at www.shoemakerfmfg.com
- 2 Throw values are measured in feet for terminal velocities of 150/100/50 FPM
- 3 Throw data is based on supply air and room air both at isothermal conditions
- 4 Effective core areas listed in chart are defined as the measurement of space between the blades actually being utilized by the air
- 5 Data obtained from tests conducted in accordance with ANSI/ASHRAE standard 70-2006

Performance Data: 100-0 Series

Duct Size	Core Eff. Area (ft ²)	Neck Velocity (FPM) Velocity Pressure	300	400	500	600	700	800	900	1000	1200
			0.007	0.011	0.017	0.024	0.034	0.044	0.055	0.068	0.100
6×6	0.131	CFM	39	52	65	79	92	105	118	131	157
		NC	<20	20	25	30	30	30	35	35	40
		Throw	2 2.5 3.5 3 4 5 4 4.5 5.5 4 5 7 5 6.5 8.5 6 7 10 6 7.5 10 7 8 12 8 9.5 14.5								
8×8	0.238	CFM	71	95	119	143	166	190	214	238	285
		NC	<20	20	25	30	30	30	35	35	40
		Throw	3 4 5 4 4.5 6 5 6 7 6 7 9 6 7.5 11 7 8.5 12 8 9 14 9 10.5 16 10 11.5 17								
10×10	0.376	CFM	113	151	188	226	263	301	339	376	452
		NC	<20	20	25	30	30	30	35	35	40
		Throw	3 4 5.5 5 5.5 6.5 6 7 8.5 7 7.5 10.5 8 9.5 12.5 9 10 14 9 11 17 10 12 18 11 13.5 20								
12×12	0.546	CFM	164	219	273	328	383	437	492	546	656
		NC	<20	25	30	30	30	30	35	35	40
		Throw	4 5 6 6 6.5 7 9 7 8 10 8 9.5 13 9 10 14 11 12.5 17 12 13.5 20 12 14.5 22 15 17 25								
14×14	0.748	CFM	225	299	374	449	524	599	674	748	898
		NC	<20	25	30	30	30	30	35	35	40
		Throw	5 6 7 6 7.5 9.5 8 10 12 9 10.5 14.5 11 13 17 12 14 19 13 15 22 15 17 25 16 19 29								
16×16	0.982	CFM	295	393	491	589	687	786	884	982	1178
		NC	<20	25	30	30	30	30	35	35	40
		Throw	6 6.5 8 7 8.5 10.5 9 10.5 12.5 10 12.5 17 12 14.5 20 14 16 22 14 16 25 16 19 29 18 22 34								
18×18	1.247	CFM	374	499	624	748	873	998	1122	1247	1497
		NC	<20	25	30	30	35	35	35	35	40
		Throw	6 7 9 8 9 11 10 11.5 14.5 11 13.5 18 13 15.5 21 16 18 24 17 20 30 18 21 31 19 23 35								
20×20	1.544	CFM	463	618	772	926	1081	1235	1390	1544	1853
		NC	<20	25	30	30	35	35	35	40	40
		Throw	7 8 10 9 10 12 11 13.5 17 12 14 19 15 17 24 17 20 28 18 21 31 20 23 34 20 24 36								
24×24	2.233	CFM	670	893	1116	1340	1563	1786	2009	2233	2679
		NC	<20	25	30	30	35	35	40	40	40
		Throw	8 9.5 11 10 11.5 14.5 13 15.5 19 15 17 23 17 20 28 20 24 33 21 25 39 22 26 40 23 28 42								

Performance Notes:

- 1 Additional performance data for sizes not listed is available at www.shoemakerfmfg.com
- 2 Throw values are measured in feet for terminal velocities of 150/100/50 FPM
- 3 Throw data is based on supply air and room air both at isothermal conditions
- 4 Effective core areas listed in chart are defined as the measurement of space between the blades actually being utilized by the air
- 5 Data obtained from tests conducted in accordance with ANSI/ASHRAE standard 70-2006

LOUVERED CEILING DIFFUSERS

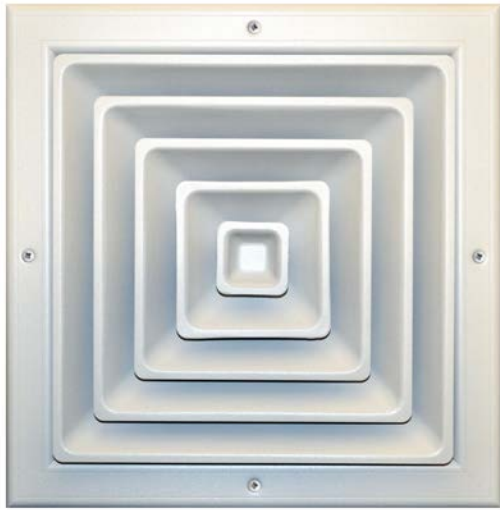

DVD-DCF

DVD Series Square and Rectangular Directional Diffuser

Standard Features:

- Directional volume diffuser
- Designed to handle high volumes of air with horizontal flow
- 14 air patterns available
- Square collar
- Countersunk mounting holes for flush appearance with color matching Phillips posi-drive screws
- Rust resistant pre-coat with durable powder finish
- Soft White

Air Pattern 4S, Sizes 6×6 through 16×16:

- Extruded aluminum surface mount frame with signature line marks
- 4-way removable steel molded core diffuser
- Available in square sizes only

All other air patterns and sizes:

- Steel formed frame
- Individual formed blades welded together to make fixed core diffuser pattern
- Available in square or rectangular sizes

Options:

- Deep ceiling frame (steel) with concealed mounting holes
MODEL: DVD-DCF
- Concealed mounting holes
MODEL: DVD-CM
- Recessed screwdriver operated Opposed Blade Damper
MODEL: DVD-O / DVD-O-DCF
- 2" ADC compliant round collar with bead for ease of installation
- T-20 Tamper Proof Screws



Air Patterns:

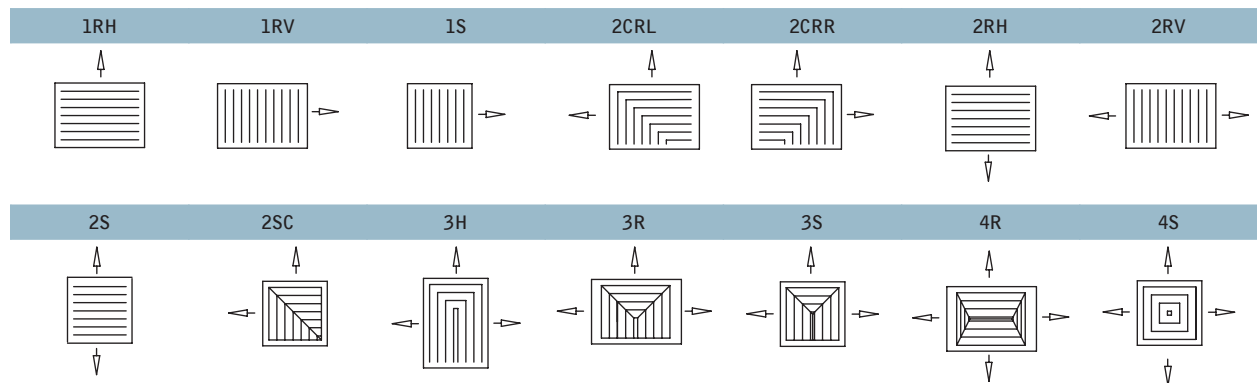

DVD Series
DVD (4S)

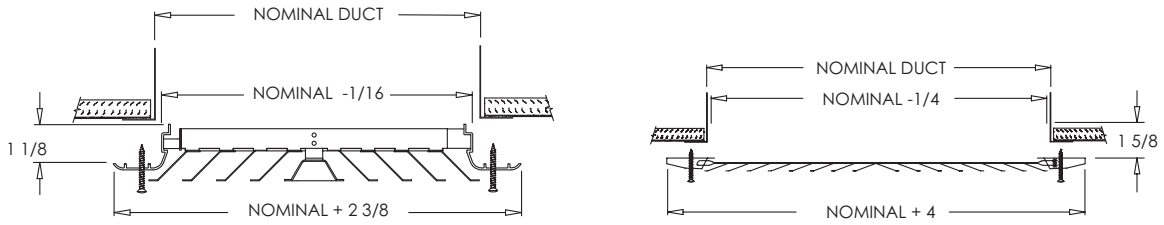

DVD-DCF (4S)

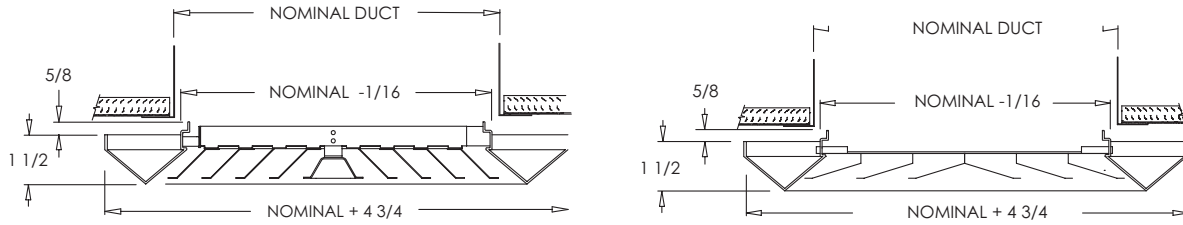

DVD-0 (4S)

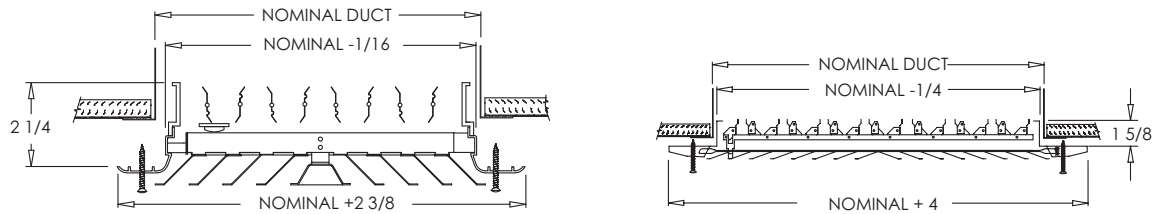

DVD-0-DCF (4S)

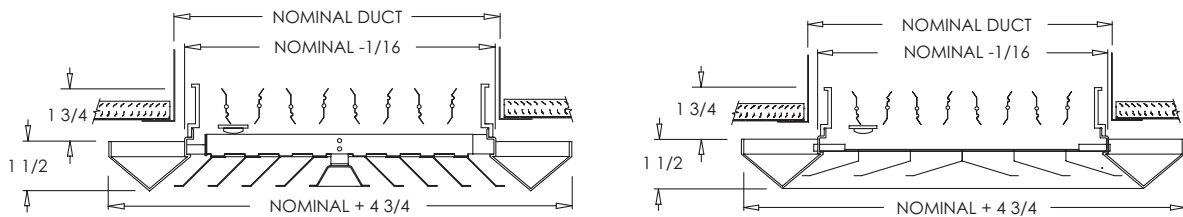

Performance Data: DVD Series (4S Air Pattern)

Duct Size	Core Patterns	Core Eff. Area (ft ²)	Neck Velocity (FPM)																							
			300			400			500			600			700			800			900					
			Total Pressure																							
			0.024																							
			0.044																							
			0.065																							
			0.096																							
			0.132																							
			0.170																							
			0.216																							
6×6	4S	0.148	Total CFM			44			59			74			89			103			118			133		
			NC			<20			<20			<20			20			20-25			25-30			30-35		
			Throw x/y			4	5.5	7.5	5	6	9	6	7	10	7	8	11	8	9	13	7	8	12	8	9	13
8×8	4S	0.278	Total CFM			83			111			139			167			195			222			250		
			NC			<20			<20			<20			20-25			25-30			30-35			35-40		
			Throw x/y			5	6.5	9	6	7	10	7	8	11	8	9	13	8	9.5	13	9	10	14	10	11	16
10×10	4S	0.449	Total CFM			135			180			225			270			315			359			404		
			NC			<20			<20			<20			20-25			25-30			30-35			35-40		
			Throw x/y			7	8	11	7	9	12	8	10	13	9	11	15	10	12	15	10	12	16	11	13.5	18
12×12	4S	0.661	Total CFM			198			265			331			397			463			529			595		
			NC			<20			<20			20-25			25-30			30-35			35			35-40		
			Throw x/y			7.5	9	12	8	10	13	9	11	14	10	12	16	11	13	17	12	14	19	13	15	20
14×14	4S	0.915	Total CFM			274			366			457			549			640			732			823		
			NC			<20			<20			20-25			25-30			30-35			35-40			40-45		
			Throw x/y			8	10	13	9	11.5	14.5	11	12.5	16	11	13	17	12	14.5	18	13	15.5	22	14	17	23
16×16	4S	1.208	Total CFM			363			483			604			725			846			967			1088		
			NC			<20			<20			20-25			25-30			30-35			35-40			40-45		
			Throw x/y			9	11.5	14.5	11	13.5	17	13	15	19	14	16	22	14	17	23	15	18	26	16	19	28
18×18	4S	1.543	Total CFM			463			617			772			926			1080			1235			1389		
			NC			<20			<20			25			30-35			35			35-40			40-45		
			Throw x/y			10	12.5	16	12	14.5	18	14	16	21	15	17	23	15	18	24	16	19	28	18	21	29
20×20	4S	1.919	Total CFM			576			768			960			1151			1343			1535			1727		
			NC			<20			20			25-30			30-35			35-40			40-45			45		
			Throw x/y			12	13	18	13	17	21	15	18	24	17	20	28	18	21	28	19	22	32	20	23	35
24×24	4S	2.793	Total CFM			838			1117			1397			1676			1955			2235			2514		
			NC			<20			20-25			25-30			30-35			35-40			40-45			45-50		
			Throw x/y			14	16	19	14	18	22	17	20	26	18	21	29	20	23	31	20	24	34	21	24	36

Performance Notes:

1 Additional performance data for sizes not listed is available at www.shoemakermg.com

2 Throw values are measured in feet for terminal velocities of 150/100/50 FPM

3 Throw data is based on supply air and room air both at isothermal conditions

4 Effective core areas listed in chart are defined as the measurement of space between the blades actually being utilized by the air

5 Data obtained from tests conducted in accordance with ANSI/ASHRAE standard 70-2006

COMBINATION SUPPLY/RETURN



SR Series Combination Curved Blade Supply and Perforated Return

Standard Features:

- Supply and return for rooftop air conditioners
- Extruded aluminum frame with individually adjustable curved blades on perimeter
- Nylon bushings on adj. blades prevent metal on metal rattle
- Perforated return face – 3/16" holes on 1/4" staggered centers
- Countersunk mounting holes for flush appearance with color matching Phillips posi-drive screws
- Rust resistant pre-coat with durable powder finish
- Soft White

Options:

- 1/2" x 1/2" x 1/2" aluminum lattice return air grille

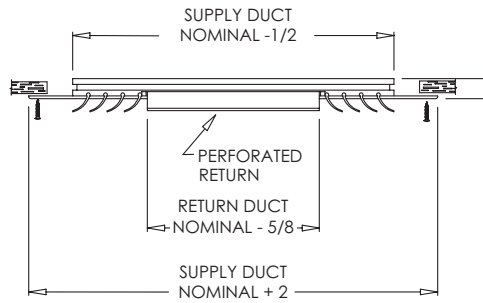

SR



Field Adjustable



High Capacity



MRI Compatible



Multi-Family



Expedited Service



Extended Leadtime

Performance Data: SR Series

Item	Duct/Neck Size	Eff. Area (ft ²)	Neck Velocity	600	800	1000	1200
SR2112	Supply 21×21	1.611	Total System Pressure	0.100	0.163	0.254	0.365
			Supply Static Pressure	0.082	0.138	0.215	0.31
	Return 12×12	0.53	Return Static Pressure	-0.018	-0.025	-0.039	-0.055
			Supply CFM	967	1289	1611	1933
SR2415	Supply 24×24	1.921	NC	25	25	25-30	35
			Throw	13	15	20	24
	Return 15×15	0.828	Total System Pressure	0.107	0.173	0.250	0.339
			Supply Static Pressure	0.096	0.155	0.225	0.305
SR3318	Supply 33×33	4.234	Return Static Pressure	-0.011	-0.018	-0.025	-0.034
			Supply CFM	1153	1537	1921	2305
	Return 18×18	1.193	NC	25-30	30	35	40
			Throw	15	17	22	26
SR3621	Supply 36×36	4.75	Total System Pressure	0.140	0.169	0.208	0.243
			Supply Static Pressure	0.125	0.15	0.185	0.214
	Return 21×21	1.623	Return Static Pressure	-0.015	-0.019	-0.023	-0.029
			Supply CFM	2540	3387	4234	5081
SR4827	Supply 48×48	8.817	NC	30	30-35	40	45
			Throw	26	32	42	50
	Return 27×27	2.683	Total System Pressure	0.143	0.176	0.221	0.260
			Supply Static Pressure	0.125	0.15	0.185	0.214
SR-T-2×2 2×2 T-Bar	Supply 22×22	1.57	Return Static Pressure	-0.018	-0.026	-0.036	-0.046
			Supply CFM	2850	3800	4750	5700
	Return 14×14	0.721	NC	40	45	45-50	50
			Throw	34	38	48	56
SR-T-2×4 2×4 T-Bar	Supply 22×46	3.511	Total System Pressure	0.169	0.222	0.285	0.350
			Supply Static Pressure	0.125	0.15	0.185	0.214
	Return 30×12	1.325	Return Static Pressure	-0.044	-0.072	-0.1	-0.136
			Supply CFM	5290	7054	8817	10580
SR-T-2×4 2×4 T-Bar	Supply 22×46	3.511	NC	45	45-50	50	>50
			Throw	46	52	60	72
	Return 30×12	1.325	Total System Pressure	0.106	0.165	0.257	0.353
			Supply Static Pressure	0.089	0.141	0.22	0.3
SR-T-2×4 2×4 T-Bar	Supply 22×46	3.511	Return Static Pressure	-0.017	-0.024	-0.037	-0.053
			Supply CFM	942	1256	1570	1884
	Return 30×12	1.325	NC	25-30	30	35	40
			Throw	14	15	18	22
SR-T-2×4 2×4 T-Bar	Supply 22×46	3.511	Total System Pressure	0.135	0.164	0.203	0.238
			Supply Static Pressure	0.121	0.146	0.181	0.21
	Return 30×12	1.325	Return Static Pressure	-0.014	-0.018	-0.022	-0.028
			Supply CFM	2107	2809	3511	4213
Return 30×12	1.325	NC	40	45	45-50	50	
		Throw	23	25	28	30	

Performance Notes:

1 Throw data is based on supply air and room air both at isothermal conditions

2 Effective areas listed in chart are defined as the measurement of space between the blades actually being utilized by the air

3 Data obtained from tests conducted in accordance with ANSI/ASHRAE standard 70-2006

GYM GRADE REGISTER

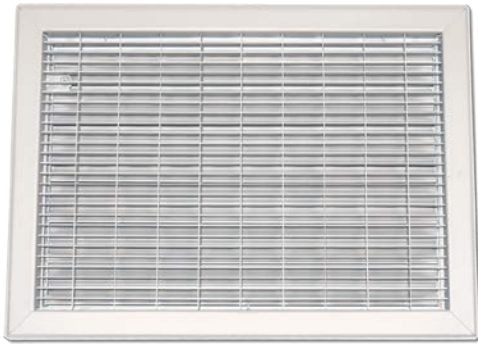

1560



1525

1560 Series Gym Grade Bar Register with 0° Deflection

Standard Features:

- Fixed bars at 0°
- Gym grade construction includes welded core and extra bar supports for heavy duty applications
- Bars run parallel to longest dimension
- Mounting holes with color matching Phillips posi-drive screws
- Recessed screwdriver operated Opposed Blade Damper
- Available in even sizes only
- Rust resistant pre-coat with durable powder finish
- Soft White

Options:

- Fixed bars at 30°
MODEL: 1525
- No mounting holes for floor application
- Bars parallel to shortest dimension
- T-20 Tamper Proof Screws

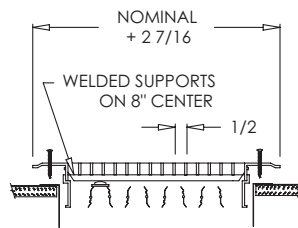

1560

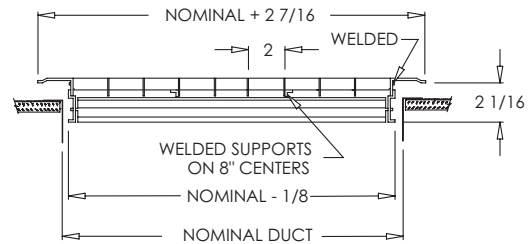

1560

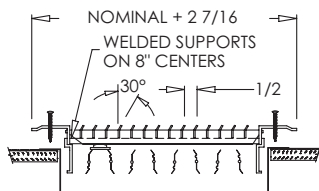

1525

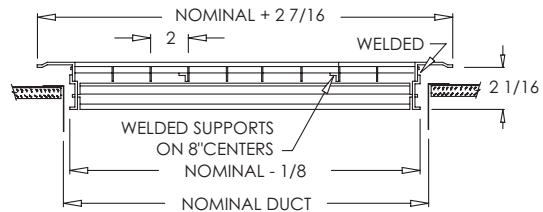

1525

Performance Data: 1560 Series

Duct Size	Core Eff. Area (ft ²)	Neck Velocity (FPM) Velocity Pressure	400			500			600			700			800			1000		
			0.011			0.017			0.024			0.034			0.044			0.068		
4x10	0.181	CFM	72			90			108			126			145			181		
		NC	20			25			30			30			35			35		
		Throw	8	9	11	10	11	13	12	13	17	14	16	21	15	17	25	17	20	30
4x12	0.219	CFM	87			109			131			153			175			219		
		NC	20			25			30			30			35			35		
		Throw	9	10	12	11	12.5	16	13	14.5	20	15	17	23	16	19	29	21	24	36
4x14	0.256	CFM	103			128			154			179			205			256		
		NC	20			25			30			30			35			35		
		Throw	10	11.5	14.5	13	14.5	18	15	17	23	16	20	27	18	21	31	23	26	38
6x10	0.282	CFM	113			141			169			197			225			282		
		NC	20			25			30			30			35			35		
		Throw	10	11.5	14.5	13	14.5	18	15	17	23	16	20	27	18	21	31	23	26	38
6x12	0.341	CFM	136			170			205			239			273			341		
		NC	20			25			30			30			35			35		
		Throw	11	12.5	16	14	16	20	16	19	25	18	21	29	19	22	34	25	29	43
6x14	0.400	CFM	160			200			240			280			320			400		
		NC	20			25			30			30			35			35		
		Throw	12	13.5	17	15	17	21	18	21	27	20	23	31	19	22	32	27	31	50
6x16	0.459	CFM	184			229			275			321			367			459		
		NC	20			25			30			30-35			35-40			40		
		Throw	12	13.5	17	16	18	22	17	20	28	22	25	33	23	26	40	29	34	50
10x10	0.484	CFM	194			242			291			339			387			484		
		NC	20			25			30-35			30-35			35-40			40		
		Throw	13	14.5	18	16	18	22	18	21	29	23	26	35	25	28	42	31	37	55
8x14	0.543	CFM	217			272			326			380			435			543		
		NC	20			25			30-35			30-35			35-40			40		
		Throw	15	17	21	18	21	25	21	24	32	24	27	37	26	30	44	31	37	57
8x16	0.624	CFM	249			312			374			437			499			624		
		NC	20			25			30-35			30-35			35-40			40		
		Throw	16	18	22	20	23	29	26	26	35	26	30	40	27	32	48	34	40	60
10x14	0.687	CFM	275			344			412			481			550			687		
		NC	20			25			30-35			30-35			35-40			40		
		Throw	16	18	22	20	24	30	24	27	37	27	32	44	30	35	53	35	41	63
12x12	0.708	CFM	283			354			425			496			566			708		
		NC	20			25			30-35			30-35			35-40			40-45		
		Throw	16	18	22	21	24	30	24	27	37	27	32	44	30	35	53	36	42	64
14x14	0.974	CFM	390			487			584			682			779			974		
		NC	20			25			35			35			40			45		
		Throw	20	23	28	24	27	33	27	32	43	31	37	51	34	40	60	42	49	73
14x20	1.406	CFM	562			703			843			984			1124			1406		
		NC	20			25			35			35			40			45		
		Throw	23	26	32	28	33	41	31	37	51	37	44	58	38	45	67	46	54	80
12x24	1.444	CFM	577			722			866			1011			1155			1444		
		NC	20			25			35			35			40			45		
		Throw	23	26	32	28	33	41	31	37	51	37	44	58	38	45	67	47	54	81
30x12	1.809	CFM	724			905			1086			1266			1447			1809		
		NC	20			25			35			35			40			45		
		Throw	26	31	39	33	39	48	37	44	61	41	49	65	42	51	75	50	59	87

Performance Notes:

1 Additional performance data for sizes not listed is available at www.shoemakerfmg.com
 2 Throw values are measured in feet for terminal velocities of 150/100/50 FPM

3 Throw data is based on supply air and room air both at isothermal conditions
 4 Effective core areas listed in chart are defined as the measurement of space between the blades actually being utilized by the air

5 Data obtained from tests conducted in accordance with ANSI/ASHRAE standard 70-2006

Performance Data: 1525 Series

Duct Size	Core Eff. Area (ft ²)	Neck Velocity (FPM) Velocity Pressure	400		500			600			700			800			1000			
			0.011			0.017			0.024			0.034			0.044			0.068		
4×10	0.172	CFM	69			86			103			120			137			172		
		NC	20			25			30			30			35			35		
		Throw	8	9	11	10	11	13	12	13	17	14	16	21	15	17	25	17	20	30
4×12	0.208	CFM	83			104			125			145			166			208		
		NC	20			25			30			30			35			35		
		Throw	9	10	12	11	12.5	16	13	14.5	20	15	17	23	16	19	29	21	24	36
4×14	0.244	CFM	97			122			146			170			195			244		
		NC	20			25			30			30			35			35		
		Throw	10	11.5	14.5	13	14.5	18	15	17	23	16	20	27	18	21	31	23	26	38
6×10	0.268	CFM	107			134			161			187			214			268		
		NC	20			25			30			30			35			35		
		Throw	10	11.5	14.5	13	14.5	18	15	17	23	16	20	27	18	21	31	23	26	38
6×12	0.324	CFM	130			162			194			227			259			324		
		NC	20			25			30			30			35			35		
		Throw	11	12.5	16	14	16	20	16	19	25	18	21	29	19	22	34	25	29	43
6×14	0.380	CFM	152			190			228			266			304			380		
		NC	20			25			30			30			35			35		
		Throw	12	13.5	17	15	17	21	18	21	27	20	23	31	19	22	32	27	31	50
6×16	0.436	CFM	174			218			262			305			349			436		
		NC	20			25			30			30-35			35-40			40		
		Throw	12	13.5	17	16	18	22	17	20	28	22	25	33	23	26	40	29	34	50
10×10	0.460	CFM	184			230			276			322			368			460		
		NC	20			25			30-35			30-35			35-40			40		
		Throw	13	14.5	18	16	18	22	18	21	29	23	26	35	25	28	42	31	37	55
8×14	0.516	CFM	207			258			310			361			413			516		
		NC	20			25			30-35			30-35			35-40			40		
		Throw	15	17	21	18	21	25	21	24	32	24	27	37	26	30	44	31	37	57
8×16	0.592	CFM	237			296			355			415			474			592		
		NC	20			25			30-35			30-35			35-40			40		
		Throw	16	18	22	20	23	29	26	26	35	26	30	40	27	32	48	34	40	60
10×14	0.653	CFM	261			326			392			457			522			653		
		NC	20			25			30-35			30-35			35-40			40		
		Throw	16	18	22	20	24	30	24	27	37	27	32	44	30	35	53	35	41	63
12×12	0.673	CFM	269			336			404			471			538			673		
		NC	20			25			30-35			30-35			35-40			40-45		
		Throw	16	18	22	21	24	30	24	27	37	27	32	44	30	35	53	36	42	64
14×14	0.925	CFM	370			463			555			648			740			925		
		NC	20			25			35			35			40			45		
		Throw	20	23	28	24	27	33	27	32	43	31	37	51	34	40	60	42	49	73
14×20	1.335	CFM	534			668			801			935			1068			1335		
		NC	20			25			35			35			40			45		
		Throw	23	26	32	28	33	41	31	37	51	37	44	58	38	45	67	46	54	80
12×24	1.371	CFM	549			686			823			960			1097			1371		
		NC	20			25			35			35			40			45		
		Throw	23	26	32	28	33	41	31	37	51	37	44	58	38	45	67	47	54	81
12×30	1.719	CFM	688			859			1031			1203			1375			1719		
		NC	20			25			35			35			40			45		
		Throw	26	31	39	33	39	48	37	44	61	41	49	65	42	51	75	50	59	87

Performance Notes:

- Additional performance data for sizes not listed is available at www.shoemakermfg.com
- Throw values are measured in feet for terminal velocities of 150/100/50 FPM
- Throw data is based on supply air and room air both at isothermal conditions
- Effective core areas listed in chart are defined as the measurement of space between the blades actually being utilized by the air
- Data obtained from tests conducted in accordance with ANSI/ASHRAE standard 70-2006



Field Adjustable



High Capacity



MRI Compatible



Multi-Family



Expedited Service



Extended Leadtime

GYM GRADE GRILLE



1610



1625

1610 Series Gym Grade Bar Grille with 0° Deflection

Standard Features:

- Fixed bars at 0°
- Gym grade construction includes welded core and extra bar supports for heavy duty applications
- Bars run parallel to longest dimension
- Mounting holes with color matching Philips posi-drive screws
- Available in even sizes only
- Rust resistant pre-coat with durable powder finish
- Soft White

Options:

- Fixed bars at 30°
MODEL: 1625
- No mounting holes for floor application
- Bars parallel to shortest dimension
- T-20 Tamper Proof Screws

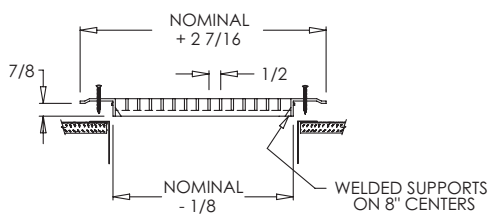

1610

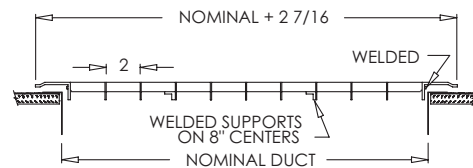

1610

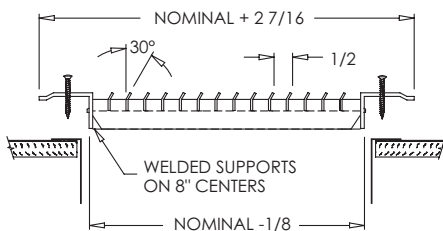

1625

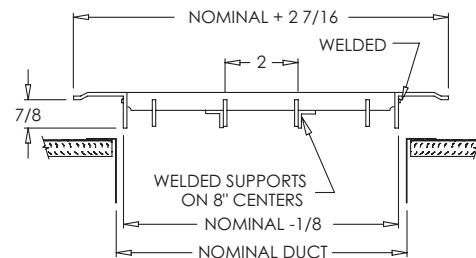

1625

Performance Data: 1610 Series

Duct Size	Core Eff. Area (ft ²)	Neck Velocity (FPM) Velocity Pressure	400	500	600	700	800	1000	1200	1400
			0.011	0.017	0.023	0.031	0.040	0.062	0.089	0.122
20×14	1.561	CFM	624	780	937	1093	1249	1561	1873	2185
24×14	1.880	CFM	752	940	1128	1316	1504	1880	2256	2632
20×18	2.022	CFM	809	1011	1213	1415	1617	2022	2426	2830
30×14	2.358	CFM	943	1179	1415	1651	1887	2358	2830	3302
24×18	2.435	CFM	974	1217	1461	1704	1948	2435	2922	3409
36×14	2.837	CFM	1135	1418	1702	1986	2270	2837	3404	3972
30×18	3.055	CFM	1222	1527	1833	2138	2444	3055	3666	4277
24×24	3.267	CFM	1307	1634	1960	2287	2614	3267	3921	4574
36×18	3.674	CFM	1470	1837	2205	2572	2940	3674	4409	5144
48×14	3.794	CFM	1518	1897	2276	2656	3035	3794	4553	5312
60×14	4.751	CFM	1900	2375	2851	3326	3801	4751	5701	6651
48×18	4.914	CFM	1966	2457	2948	3440	3931	4914	5897	6880
36×24	4.931	CFM	1972	2465	2958	3452	3945	4931	5917	6903
30×30	5.144	CFM	2057	2572	3086	3600	4115	5144	6172	7201
60×18	6.154	CFM	2461	3077	3692	4308	4923	6154	7384	8615
48×24	6.594	CFM	2638	3297	3957	4616	5275	6594	7913	9232
60×24	8.258	CFM	3303	4129	4955	5780	6606	8258	9909	11561

Performance Notes:

- 1 Additional performance data for sizes not listed is available at www.shoemakermfg.com
- 2 Effective core areas listed in chart are defined as the measurement of space between the blades actually being utilized by the air
- 3 Data obtained from tests conducted in accordance with ANSI/ASHRAE standard 70-2006

Performance Data: 1625 Series

Duct Size	Core Eff. Area (ft ²)	Neck Velocity (FPM) Velocity Pressure	400	500	600	700	800	1000	1200	1400
			0.011	0.017	0.023	0.031	0.040	0.062	0.089	0.122
20×14	1.483	CFM	593	741	890	1038	1186	1483	1779	2076
24×14	1.786	CFM	714	893	1072	1250	1429	1786	2143	2500
20×18	1.921	CFM	768	960	1152	1344	1536	1921	2305	2689
30×14	2.240	CFM	896	1120	1344	1568	1792	2240	2689	3137
24×18	2.313	CFM	925	1157	1388	1619	1851	2313	2776	3238
36×14	2.695	CFM	1078	1348	1617	1887	2156	2695	3234	3773
30×18	2.902	CFM	1161	1451	1741	2031	2322	2902	3482	4063
24×24	3.104	CFM	1242	1552	1862	2173	2483	3104	3725	4346
36×18	3.491	CFM	1396	1745	2094	2444	2793	3491	4189	4887
48×14	3.604	CFM	1442	1802	2163	2523	2883	3604	4325	5046
60×14	4.513	CFM	1805	2257	2708	3159	3611	4513	5416	6319
48×18	4.668	CFM	1867	2334	2801	3268	3735	4668	5602	6536
36×24	4.684	CFM	1874	2342	2811	3279	3747	4684	5621	6558
30×30	4.886	CFM	1955	2443	2932	3420	3909	4886	5864	6841
60×18	5.846	CFM	2338	2923	3508	4092	4677	5846	7015	8184
48×24	6.265	CFM	2506	3132	3759	4385	5012	6265	7517	8770
60×24	7.845	CFM	3138	3922	4707	5491	6276	7845	9414	10983

Performance Notes:

- 1 Additional performance data for sizes not listed is available at www.shoemakermfg.com
- 2 Effective core areas listed in chart are defined as the measurement of space between the blades actually being utilized by the air
- 3 Data obtained from tests conducted in accordance with ANSI/ASHRAE standard 70-2006

LATTICE FILTER GRILLE



620FG Lattice Filter Grille

Standard Features:

- 1/2" × 1/2" × 1/2" aluminum lattice face
- Hinged removable extruded aluminum face frame with signature line marks
- Hinges parallel to longest side
- Face set in an outer filter grille frame
- Hand operated lever for easy filter access
- 4-way reversible door on square sizes
- 2-way reversible door on rectangular sizes
- Concealed mounting holes
- Holds up to a 1" filter (not included) with filter retention tabs
- MODEL: 620FG1**
- Rust resistant pre-coat with durable powder finish
- Soft White

Options:

- 2" Filter capacity
MODEL: 620FG2
- 4" Filter capacity
MODEL: 620FG4
- Extruded aluminum frame with signature line marks set in an outer aluminum filter grille frame (all aluminum)
MODEL: 600FG1
- 1/2" × 1/2" × 1/2" 45° sightproof aluminum lattice, deflection parallel to longest dimension
MODEL: 645FG1/645FG2
- 1/2" × 1/2" × 1/2" 45° sightproof aluminum lattice, deflection parallel to shortest dimension
MODEL: 646FG1/646FG2
- Perforated face filter grille
MODEL: 620PFG1/620PFG2/620PFG4
- Alternative hinge and latch options – Filter Grille Order Supplement form on website

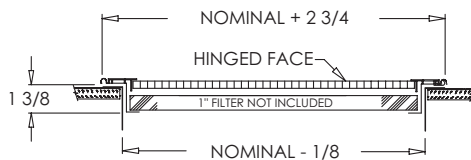

620FG1

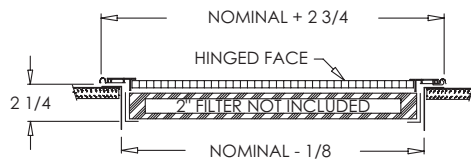

620FG2

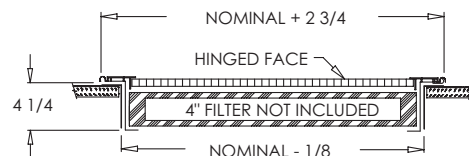

620FG4

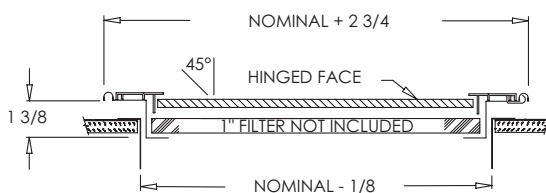

645FG1

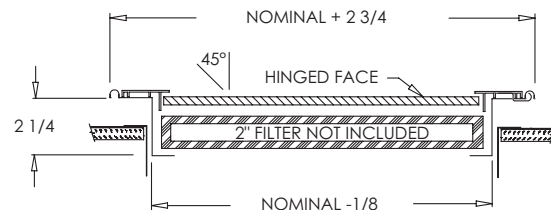

645FG2

Performance Data: 620FG Series

Duct Size	Core Eff. Area (ft ²)	Neck Velocity (FPM) Velocity Pressure	400	500	600	700	800	900	1000
			0.032	0.048	0.070	0.092	0.120	0.140	0.160
10×10 14×8	0.564	CFM	226	282	338	395	451	508	564
12×12 22×6	0.827	CFM	331	413	496	579	661	744	827
14×14 24×8	1.139	CFM	456	570	683	797	911	1025	1139
16×16 30×8	1.502	CFM	601	751	901	1051	1201	1351	1502
18×18 20×16	1.914	CFM	766	957	1148	1340	1531	1723	1914
20×20 25×16	2.377	CFM	951	1188	1426	1664	1901	2139	2377
24×20 30×16	2.864	CFM	1146	1432	1718	2005	2291	2578	2864
25×20 36×14	2.986	CFM	1194	1493	1792	2090	2389	2687	2986
24×24 36×16	3.452	CFM	1381	1726	2071	2416	2761	3106	3452
30×24	4.333	CFM	1733	2166	2600	3033	3466	3900	4333
36×24	5.214	CFM	2086	2607	3128	3650	4171	4693	5214
30×30	5.439	CFM	2176	2720	3263	3807	4351	4895	5439

Performance Notes:

1 Additional performance data for sizes not listed is available at www.shoemakermfg.com

2 Effective core areas listed in chart are defined as the measurement of space between the blades actually being utilized by the air

3 Data obtained from tests conducted in accordance with ANSI/ASHRAE standard 70-2006



Field Adjustable



High Capacity



MRI Compatible



Multi-Family



Expedited Service



Extended Leadtime

FIXED BLADE FILTER GRILLE



905FG Fixed 45° Airfoil Blade Filter Grille

Standard Features:

- Fixed 45° aluminum airfoil blades parallel to the longest dimension
- Hinged removable extruded aluminum face frame with signature line marks
- Hinges parallel to longest side
- Face set in an outer filter grille frame
- Hand operated lever for easy filter access
- 4-way reversible door on square sizes
- 2-way reversible door on rectangular sizes
- Concealed mounting holes
- Holds up to a 1" filter (not included) with filter retention tabs
- MODEL: 905FG1**
- Rust resistant pre-coat with durable powder finish
- Soft White

Options:

- 2" Filter capacity
MODEL: 905FG2
- 4" Filter capacity
MODEL: 905FG4
- Blades parallel to shortest dimension
MODEL: 906FG1/906FG2/906FG4
- Adjustable airfoil blade filter grille
MODEL: 901FG/902FG
- Fixed 0° aluminum airfoil blades
MODEL: 907FG/908FG
- Alternative hinge and latch options – see Filter Grille Order Supplement form on website

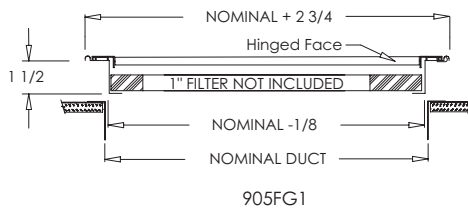

905FG1

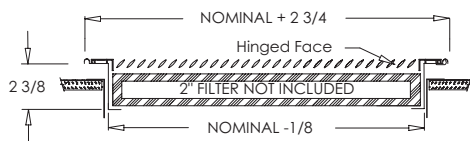

905FG2



Performance Data: 905FG Series

Duct Size	Core Eff. Area (ft ²)	Neck Velocity (FPM) Velocity Pressure	400	500	600	700	800	900
			0.032	0.048	0.070	0.092	0.120	0.140
8×8 12×6	0.355	CFM	142	177	213	248	284	319
10×10 14×8	0.569	CFM	228	285	341	398	455	512
12×12	0.834	CFM	333	417	500	583	667	750
14×14 24×8	1.148	CFM	459	574	689	804	919	1034
16×16 30×8	1.514	CFM	605	757	908	1060	1211	1362
18×18 20×16	1.929	CFM	772	965	1158	1350	1543	1736
20×20 25×16	2.361	CFM	945	1181	1417	1653	1889	2125
24×20 30×16	2.852	CFM	1141	1426	1711	1997	2282	2567
24×24 36×16	2.971	CFM	1188	1485	1782	2079	2377	2674
25×20 36×14	3.437	CFM	1375	1719	2062	2406	2750	3094
30×24	4.325	CFM	1730	2162	2595	3027	3460	3892
36×24	5.212	CFM	2085	2606	3127	3648	4170	4691
30×30	5.429	CFM	2172	2714	3257	3800	4343	4886
36×36	7.873	CFM	3149	3937	4724	5511	6299	7086

Performance Notes:

1 Additional performance data for sizes not listed is available at www.shoemakermgf.com

2 Effective core areas listed in chart are defined as the measurement of space between the blades actually being utilized by the air

3 Data obtained from tests conducted in accordance with ANSI/ASHRAE standard 70-2006

FIXED BLADE FILTER GRILLE



935FG Fixed 45° Steel Blade Filter Grille

Standard Features:

- Roll formed steel blades fixed at 45° parallel to the longest dimension
- Hinged removable extruded aluminum face frame with signature line marks
- Hinges parallel to longest side
- Face set in an outer filter grille frame
- Hand operated lever for easy filter access
- 4-way reversible door on square sizes
- 2-way reversible door on rectangular sizes
- Concealed mounting holes
- Holds up to a 1" filter (not included) with filter retention tabs
- MODEL: 935FG1**
- Rust resistant pre-coat with durable powder finish
- Soft White

Options:

- 2" Filter capacity
MODEL: 935FG2
- 4" Filter capacity
MODEL: 935FG4
- Blades parallel to the shortest dimension
MODEL: 936FG1/936FG2/936FG4
- Alternative hinge and latch options – see Filter Grille Order Supplement form on website



935FG1

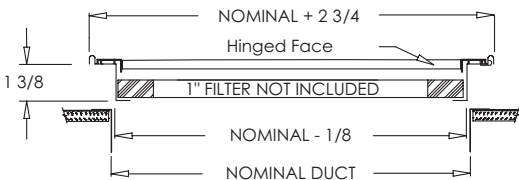

935FG1

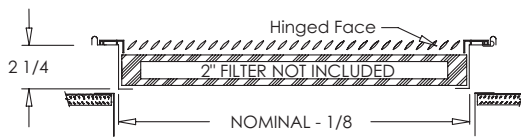

935FG2

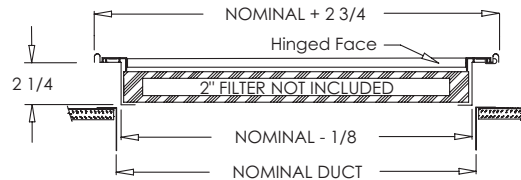

935FG2

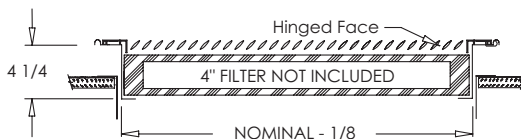

935FG4



935FG4

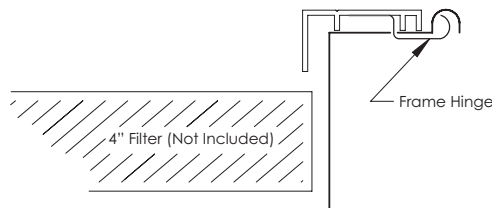

Field Adjustable



High Capacity



MRI Compatible



Multi-Family



Expedited Service



Extended Leadtime

Performance Data: 935FG Series

Duct Size	Core Eff. Area (ft ²)	Neck Velocity (FPM) Velocity Pressure	300	400	500	600	700	800	900
			0.007	0.010	0.023	0.040	0.064	0.090	0.123
10×10	0.569	CFM	171	228	285	341	398	455	512
12×12	0.834	CFM	250	333	417	500	583	667	750
14×14	1.148	CFM	345	459	574	689	804	919	1034
16×16	1.514	CFM	454	605	757	908	1060	1211	1362
18×18	1.929	CFM	579	772	965	1158	1350	1543	1736
20×12	1.393	CFM	418	557	696	836	975	1114	1253
20×14	1.635	CFM	490	654	817	981	1144	1308	1471
20×16	1.877	CFM	563	751	938	1126	1314	1502	1689
20×20	2.361	CFM	708	945	1181	1417	1653	1889	2125
24×12	1.682	CFM	505	673	841	1009	1177	1346	1514
24×14	1.975	CFM	592	790	987	1185	1382	1580	1777
24×16	2.267	CFM	680	907	1134	1360	1587	1814	2040
24×20	2.852	CFM	856	1141	1426	1711	1997	2282	2567
25×12	1.752	CFM	526	701	876	1051	1226	1402	1577
25×14	2.057	CFM	617	823	1028	1234	1440	1645	1851
25×16	2.361	CFM	708	945	1181	1417	1653	1889	2125
25×20	2.971	CFM	891	1188	1485	1782	2079	2377	2674
30×12	2.116	CFM	635	847	1058	1270	1481	1693	1905
30×14	2.484	CFM	745	994	1242	1491	1739	1988	2236
30×16	2.852	CFM	856	1141	1426	1711	1997	2282	2567
30×20	3.589	CFM	1077	1435	1794	2153	2512	2871	3230
36×20	4.325	CFM	1297	1730	2162	2595	3027	3460	3892
40×20	4.816	CFM	1445	1926	2408	2889	3371	3853	4334

Performance Notes:

1 Additional performance data for sizes not listed is available at www.shoemakerfg.com

2 Effective core areas listed in chart are defined as the measurement of space between the blades actually being utilized by the air

3 Data obtained from tests conducted in accordance with ANSI/ASHRAE standard 70-2006



FIXED BLADE FILTER GRILLE



915FG Fixed Bar Blade Filter Grille

Standard Features:

- Fixed 45° aluminum bar blades parallel to longest dimension
 - Hinged removable extruded aluminum face frame with signature line marks
 - Hinges parallel to longest side
 - Face set in an outer filter grille frame
 - Hand operated lever for easy filter access
 - 4-way reversible door on square sizes
 - 2-way reversible door on rectangular sizes
 - Concealed mounting holes
 - Holds up to a 1" filter (not included) with filter retention tabs
- MODEL: 915FG1**
- Rust resistant pre-coat with durable powder finish
 - Soft White

Options:

- 2" Filter capacity
MODEL: 915FG2
- 4" Filter capacity
MODEL: 915FG4
- Blades parallel to shortest dimension
MODEL: 916FG1/916FG2/916FG4
- Alternative hinge and latch options – see Filter Grille Order Supplement form on website

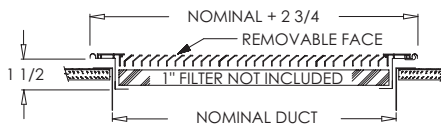

915FG1

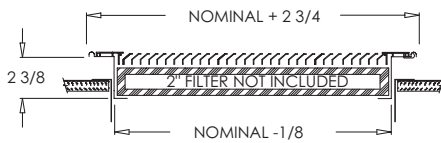

915FG2

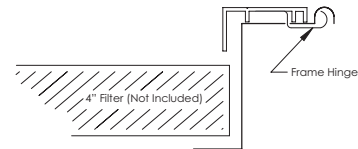

Performance Data: 915FG Series

Duct Size	Core Eff. Area (ft ²)	Neck Velocity (FPM) Velocity Pressure	400	500	600	700	800	900	900
			0.038	0.048	0.070	0.092	0.120	0.140	0.123
10×10 14×8	0.511	CFM	205	256	307	358	409	460	512
12×12 22×6	0.749	CFM	299	374	449	524	599	674	750
14×14 24×8	1.031	CFM	413	516	619	722	825	928	1034
16×16 30×8	1.359	CFM	544	679	815	951	1087	1223	1362
18×18 20×16	1.732	CFM	693	866	1039	1212	1385	1559	1736
20×20 25×16	2.150	CFM	860	1075	1290	1505	1720	1935	2153
24×20 30×16	2.911	CFM	1165	1456	1747	2038	2329	2620	2911
24×24 36×16	3.121	CFM	1248	1561	1873	2185	2497	2809	3121
25×20 36×14	3.520	CFM	1408	1760	2112	2464	2816	3168	3520
30×24	4.655	CFM	1862	2327	2793	3258	3724	4189	4655
36×24	6.146	CFM	2458	3073	3688	4302	4917	5531	6146
30×30	5.250	CFM	2100	2625	3150	3675	4200	4725	5250

Performance Notes:

- 1 Additional performance data for sizes not listed is available at www.shoemakerfmg.com
- 2 Effective core areas listed in chart are defined as the measurement of space between the blades actually being utilized by the air
- 3 Data obtained from tests conducted in accordance with ANSI/ASHRAE standard 70-2006

ROUND CEILING DIFFUSER



RDA Series Adjustable Round Ceiling Diffuser

Standard Features:

- Adjustable round 3 cone ceiling diffuser
- Air pattern adjusts from horizontal to vertical by rotating core
- Thread adjustment design offers multiple throw configurations
- Spring latch removable core allows for easy installation
- 2" round collar for ease of installation
- Rust resistant pre-coat with durable powder finish
- Soft White

Options:

- Opposed Blade Radial Damper
MODEL: RDA-0BR

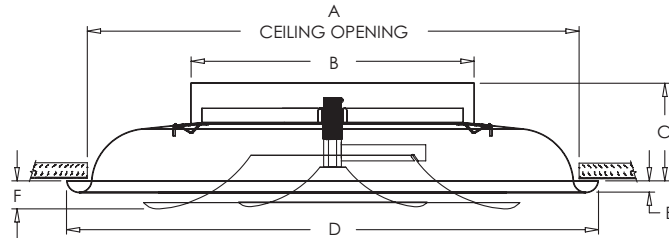

RDA

RDA Dimensions

Size	A	B	C	D	E	F
6"	11 3/4"	5 7/8"	3 3/8"	12 3/4"	3/4"	1 3/4"
8"	11 3/4"	7 7/8"	3 3/8"	12 3/4"	3/4"	1 3/4"
10"	17"	9 7/8"	4 1/8"	19 1/4"	3/4"	1 3/4"
12"	17"	11 7/8"	4 1/8"	19 1/4"	3/4"	1 3/4"
14"	23 3/4"	13 7/8"	4 1/2"	25 15/16"	3/4"	1 3/4"
16"	23 3/4"	15 7/8"	4 1/2"	25 15/16"	3/4"	1 3/4"
18"	28 1/2"	17 7/8"	5 1/8"	30 3/4"	3/4"	1 3/4"
20"	28 1/2"	19 7/8"	5 1/8"	30 3/4"	3/4"	1 3/4"
22"	34 3/4"	21 7/8"	6 3/4"	37"	3/4"	1 3/4"
24"	34 3/4"	23 7/8"	6 3/4"	37"	3/4"	1 3/4"

* See website for RDA performance data and additional dimensions and sizes

ALUMINUM ROUND DIFFUSERS



1201 Series Aluminum Adjustable Round Diffuser

Standard Features:

- Double deflection aluminum wall or ceiling register
- Heavy gauge aluminum frame
- Individually adjustable extruded aluminum airfoil blades
- Provides wide dispersion patterns to long throw narrow air streams
- Hidden mounting mechanism
- Bright White

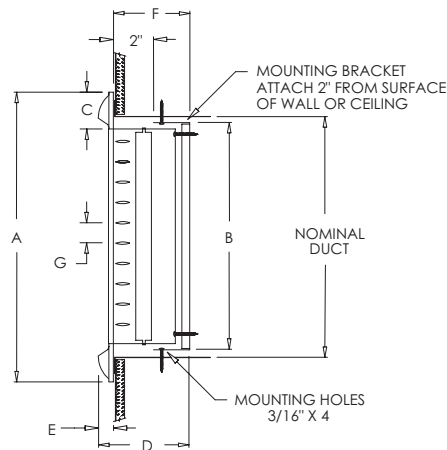

1201

1201 Series Dimensions

Size	A	B	C	D	E	F	G
6"	7 5/8"	5 13/16"	1 7/32"	4 9/32"	15/32"	5 1/2"	21/32"
8"	10"	7 25/32"	1 13/32"	4 9/32"	15/32"	5 1/2"	23/32"
10"	12 5/8"	9 3/4"	1 25/32"	4 13/32"	19/32"	5 1/2"	29/32"
12"	14 19/32"	11 23/32"	1 25/32"	4 13/32"	19/32"	5 1/2"	15/16"
14"	16 9/16"	13 11/16"	1 25/32"	4 13/32"	19/32"	5 1/2"	15/16"
16"	18 17/32"	15 21/32"	1 25/32"	4 13/32"	19/32"	5 1/2"	31/32"
20"	23 5/8"	19 23/32"	2 3/8"	4 31/32"	29/32"	6 11/16"	31/32"
24"	27 9/16"	23 11/16"	2 3/8"	4 31/32"	29/32"	6 11/16"	31/32"



Field Adjustable



High Capacity



MRI Compatible



Multi-Family



Expedited Service



Extended Leadtime

ALUMINUM ROUND DIFFUSERS



1202 Series Aluminum Round Spot Diffuser

Standard Features:

- Solid aluminum rotatable body
- Excellent for spot heating and cooling, can move conditioned air from an inaccessible place into the work environment
- Precision adjustable aluminum air flow exit plate
- Double felt flange body seal to prevent air leakage
- Closed cell neoprene felt mounting gasket
- Easy adjustment of air flow by turn of a knob
- Maximum rotation angle up to 33° to 42° in all directions
- Anodized Finish

Options:

- Exposed duct mount with round duct adapter
MODEL: 1202R
- Panel mount with up to 4 diffusers per panel
MODEL: 1205
- Contact customer service for additional color options

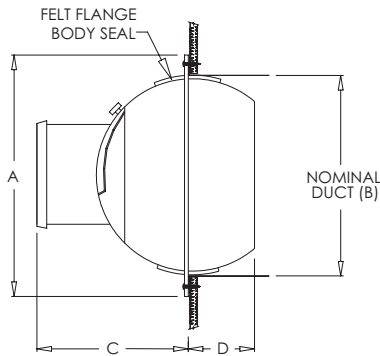

1202

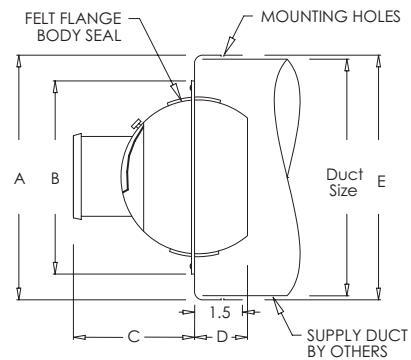

1202R

1202 Series Dimensions

Size	A	B	C	D
1202-4	5 1/2"	4 11/32"	2 9/16"	15/16"
1202-6	7 15/32"	6 5/16"	3 11/16"	1 1/2"
1202-8	9 27/32"	8 3/16"	4 23/32"	1 23/32"
1202-10	12 3/4"	11 1/32"	6 27/32"	1 31/32"
1202-12	14 9/32"	12 17/32"	7 7/8"	2 15/32"
1202-16	18 1/2"	16 23/32"	9 3/4"	3 5/8"
1202-18	21 1/16"	19 1/8"	11 5/8"	3 3/4"
1202-20	21 1/16"	19 1/8"	11 5/8"	3 3/4"

1202R Series Dimensions

Size	Duct Size	A	B	C	D	E
1202R-6	8"	8 11/32"	7 15/32"	3 11/16"	1 1/2"	8 1/4"
1202R-7	10"	10 3/8"	8 3/32"	4 3/8"	1 1/2"	10 1/4"
1202R-8	11"	11 3/8"	9 27/32"	4 23/32"	1 23/32"	11 1/4"
1202R-10	14"	14 3/8"	12 3/4"	6 27/32"	1 31/32"	14 1/4"
1202R-12	16"	16 3/8"	14 9/32"	7 7/8"	2 15/32"	16 1/4"
1202R-16	20"	20 3/8"	18 1/2"	9 3/4"	3 5/8"	20 1/4"
1202R-18	24"	24 3/8"	21 1/16"	11 5/8"	3 3/4"	24 1/4"
1202R-20	24"	24 3/8"	21 1/16"	11 5/8"	3 3/4"	24 1/4"

ALUMINUM ROUND DIFFUSERS



1203 Series Aluminum Turbo Nozzle Diffuser

Standard Features:

- Aluminum construction deep housing and inner concentric rings
- Designed for high volume long throw applications
- Adjustable air direction
- Easily installed with use of strong spring clips
- No screws necessary for wall mounting resulting in a clean appearance
- Anodized finish

Options:

- Panel mount with up to 4 diffusers per panel

MODEL: 1204

- Contact customer service for additional color options

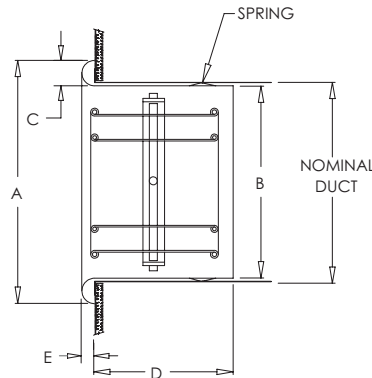

1203

1203 Series Dimensions

Size	A	B	C	D	E
4"	4 3/4"	3 5/8"	5/8"	2"	1/2"
6"	7 3/16"	5 17/32"	7/8"	3 11/32"	11/16"
8"	9 13/32"	7 17/32"	1"	4 1/4"	3/4"
10"	11 7/8"	9 1/2"	1 1/4"	5 1/16"	15/16"
12"	14 11/32"	11 15/32"	1 1/2"	4 7/8"	1 1/8"
14"	16 5/8"	13 7/16"	1 21/32"	4 3/4"	1 7/32"
16"	18 25/32"	15 13/32"	1 3/4"	4 11/16"	1 5/16"
20"	23 7/16"	19 9/16"	2"	6 1/2"	1 1/2"
24"	27 7/16"	23 9/16"	2"	6 1/2"	1 1/2"

ARCHITECTURAL STAMPED PATTERN GRILLES

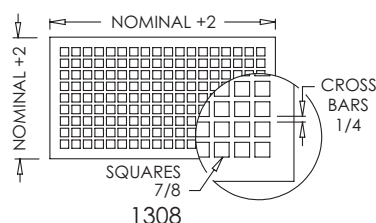
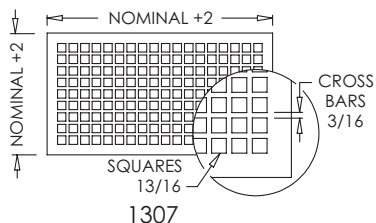
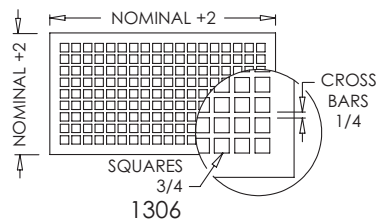
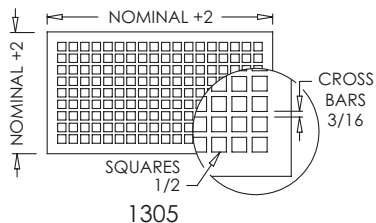
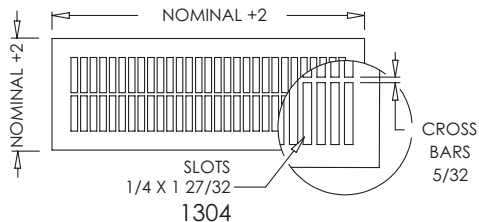
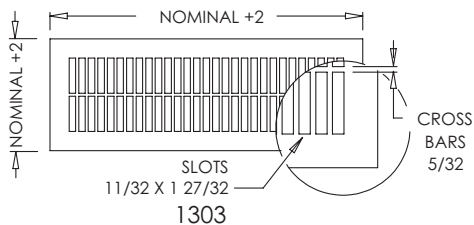
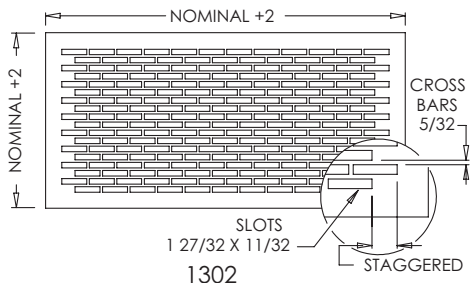
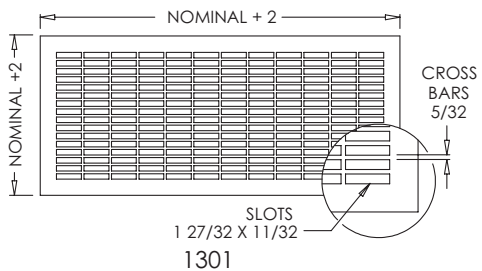
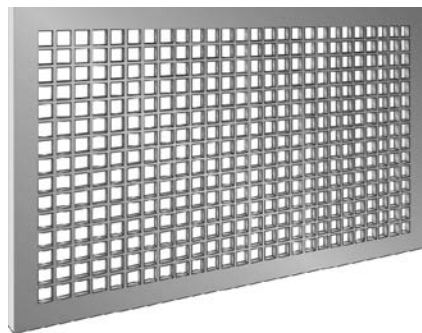

1301-1308 Series Architectural Design Stamped Pattern Grilles

Standard Features:

- 1" rim size (2" larger than nominal duct size)
- 14 gauge stainless steel construction
- Countersunk mounting holes for flush appearance with color matching screws

Rectangular Patterns:

MODEL	SLOT PATTERN SIZE	CROSS BARS	FREE AREA
1301	1-27/32" × 11/32"	5/32"	75%
1302	1-27/32" × 11/32" (staggered slots)	5/32"	73%
1303	1-27/32" × 11/32"	5/32"	75%
1304	1-27/32" × 1/4"	5/32"	54%

Square Patterns:

MODEL	SQUARE PATTERN SIZE	CROSS BARS	FREE AREA
1305	1/2"	3/16"	53%
1306	3/4"	1/4"	57%
1307	13/16"	3/16"	69%
1308	7/8"	1/4"	60%

Options:

- Tamper proof screws
- Contact customer service for additional color options



COMMERCIAL ACCESSORIES

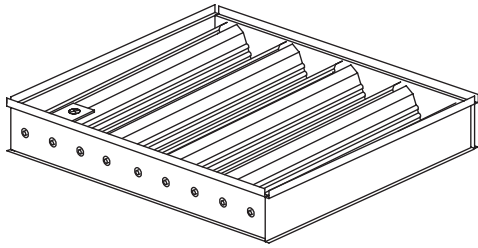

OBD OPPOSED BLADE DAMPER

Standard Features:

- Field installable screwdriver operated Opposed Blade Damper
- Nylon bushings on adj. blades prevent metal on metal rattle
- Fully adjustable and provides complete shut off in closed position
- Effectively controls airflow without disrupting air patterns
- Included standard or as an option on products where noted
- Available in sizes 4"×4" – 24"×24"
- Mill finish

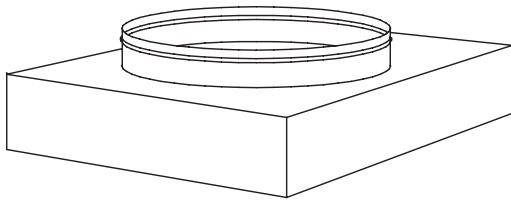

NLC Round Collar

Standard Features:

- 2" ADC compliant collar with roll formed retention bead
- Square to round transition for round duct installation
- Included standard or as an option on products where noted
- Can be installed in field
- Box sizes available in 6"×6" through 24"×24"
- Collar sizes available in 6" through to 24" (must be equal to or smaller than box size)
- Mill finish

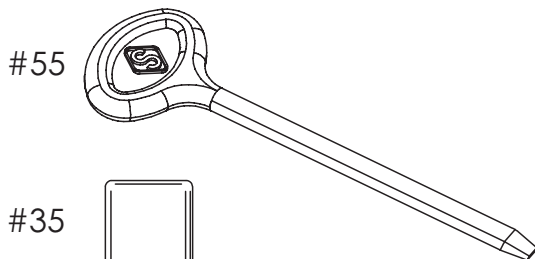

Miscellaneous Commercial Accessories

- #35 – Handle cap for lever operated dampers
- #55 – BD Handle, plastic adjustment tool



Field Adjustable



High Capacity



MRI Compatible



Multi-Family



Expedited Service



Extended Leadtime

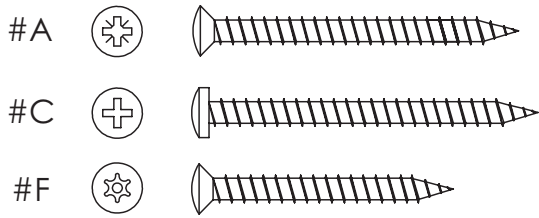

#45

#46

Screws and Bits

Screws:

- #A – 1 7/8" Philip's posi-drive Oval-head screw
- #C – 8 x 2" Philip's Pan-head screw (baseboard products)

Tamper Proof Screws:

- #F – T-20 Torx Tamper Proof screw

Bits:

- POSI BIT – 1" Philips posi-drive bit
- POSI BIT Long – 1 15/16" Philips posi-drive bit
- #I – T-20 Torx Tamper Proof bit



Touch-up Paint

- #45 Driftwood Tan touch-up paint
- #46 Soft White touch-up paint











OVERVIEW

The Shoemaker Linear product line is a robust selection of custom extruded aluminum products to meet all application, performance and architectural requirements.

Product Key

The product key located on the bottom of each page uses symbols to note options, features and services that are found repeatedly throughout this section of the catalog:

-  **STANDARD COLOR**
Rust resistant pre-coat with durable powder coat paint finish in Soft White or Driftwood Tan.
-  **DESIGNER COLOR**
Rust resistant pre-coat with durable powder coat paint finish available in custom colors. See appendix or website for list of available colors. Additional charges apply.
-  **ALUMINUM PAINT**
Closely replicates a cleaned aluminum finish with the added benefits of our powder coat painting process. Additional charges apply.
-  **SATIN ANODIZED**
Constructed with satin anodized aluminum extrusions best described as a polished aluminum.
-  **FIELD ADJUSTABLE**
Product has standard features and/or options to allow for adjustment in the field.
-  **HIGH CAPACITY**
Product is designed to deliver high volumes of air.
-  **MRI COMPATIBLE**
Constructed with MRI compatible materials (standard product or available option).
-  **EXPEDITED SERVICES PROGRAM**
Available with Expedited Service Program, products manufactured faster than standard lead times. Additional charges apply. See website for program details.
-  **EXTENDED LEADTIME**
Product not available in our standard lead time. Contact customer service for lead time quote.

Linear Bar Diffusers and Grilles are a beautifully constructed extruded aluminum bar supply or return diffuser and grilles designed for floor, sill, sidewall, and ceiling applications. The clean lines and architectural appeal also translate into efficient air distribution.

Linear Slot Diffusers are a conventional slotted extruded aluminum supply or return diffuser designed for both directional and volume discharge. They are field adjustable and provide flexible air patterns depending on final room layout and configuration.

Linear Air Bar Diffusers are a slotted extruded aluminum diffuser with an appealing architectural look designed for large volumes of air. The variety of wide slot widths allow for more CFM per square foot than a conventional Linear Slot Diffuser.

How to Order:

1. Select a series: Linear Bar Diffusers and Grilles, Linear Slot Diffuser, Linear Air Bar Diffuser
2. Select a Mounting Type
3. Select diffuser/return options
4. Select miscellaneous parts (options)
5. Select size
6. Select finish

Mounting Types:

Mounting Type	Description	Linear Air Bar	Linear Slot	Linear Bar
1	T-Bar Mount with Narrow Frame		✓	✓
2	T-Bar Mount with Wide Frame	✓	✓	✓
3	Tape and Mud Mount (frameless appearance)	✓	✓	✓
4	Surface Mount	✓	✓	✓
5	Concealed Mount		✓	
6	Duct Bracket Mount	✓	✓	✓
7	Floor/Sill Mount			✓
8	Removable Core with Flangeless Mounting Frame			✓
9	Removable Core with Frame			✓
10	1" Filter Grille Frame			✓
11	2" Filter Grille Frame			✓
12	Core only			✓

LINEAR BAR GRILLES & DIFFUSERS



Linear Bar Surface Mount



Linear Bar Removable Core with Flangeless Mounting Frame



Linear Bar Removable Core with Frame



Linear Bar Floor / Sill Mount



Linear Bar Series

Standard Features:

- Precision aluminum construction for clean styling and efficient air distribution
- Designed for heating or cooling applications and ceiling, side wall or sill installations
- Extruded aluminum frame with signature line marks (on applicable models)
- Bar spacing is 1/2" or 1/3" on center spacing with 0° or 20° deflection; actual spacing between bars is 3/8" and 1/4" respectively
- Available in lengths up to 144" in one piece (may vary for shipping and manufacturing considerations)
- 1/8" thick core blades run parallel to longest dimension
- Satin Anodized*
* Type 10 & 11 filter grille soft white finish

Available Cores:

- 1/2" – 0°
- 1/2" – 20°
- 1/3" – 0°
- 1/3" – 20° (not available on frame types 3, 6, 8, 9)

Available Mounting Types:

- 11 different options. See chart on page 128 and drawings for details.

Available Options:

- See charts on pages 131–132 and drawings for details



Available Cores:

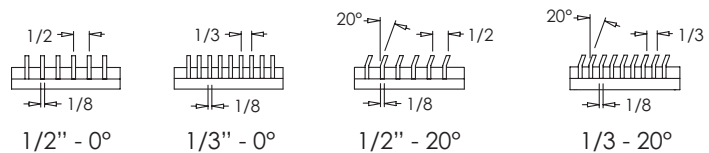

Mounting Types:

Shown with 1/2" – 0° deflection core (overall product dimensions remain the same for all available cores)

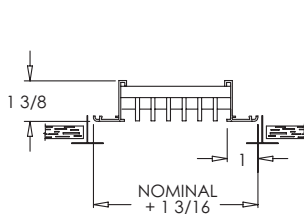

TYPE 1
T-Bar Narrow Frame

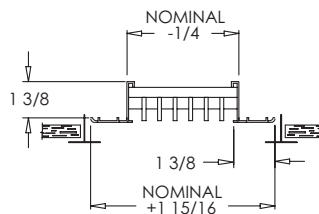

TYPE 2
T-Bar Wide Frame

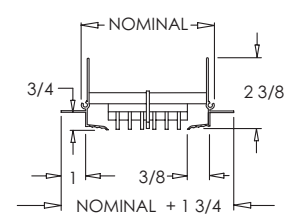

TYPE 3
Tape and Mud
(Product manufactured to exact width specification)

Mounting Types (continued from previous page):

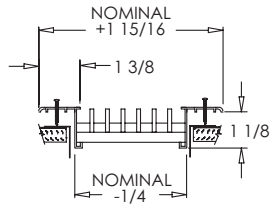

TYPE 4
Surface Mount

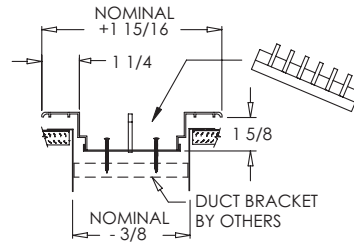

TYPE 6
Duct Mount Bracket

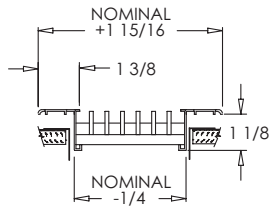

TYPE 7
Floor/Sill Mount

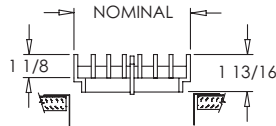

TYPE 8
Removable Core with
Flangeless Mounting Frame
(Product manufactured to exact
width and length specifications)

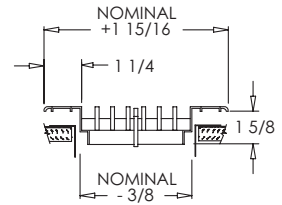

TYPE 9
Removable Core with Frame

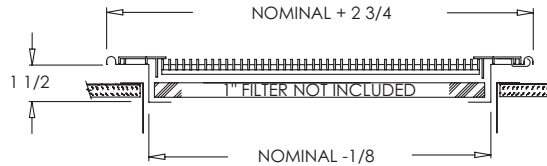

TYPE 10
1" Filter Grille Frame

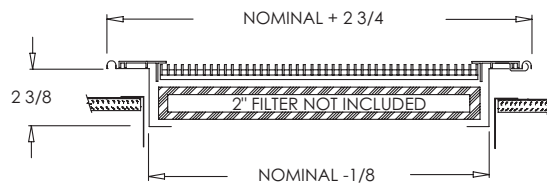

TYPE 11
2" Filter Grille Frame

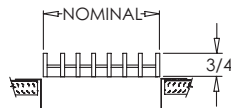

TYPE 12
Core Only
(Product manufactured to exact
width and length specifications)

Mounting Type Notes:

- Length dimension undersized -1/4" except for mounting types 8 and 12.

LINEAR BAR SERIES

Product Options	T-Bar Mount with Narrow Frame	T-Bar Mount with Wide Frame	Tape and Mud Mount	Surface Mount	Duct Bracket Mount
1" Frame width	Standard	—	—	Optional	—
1 1/4" Frame width	—	—	—	Optional	—
1 3/8" Frame width	—	Standard	—	Standard	Standard
OBD: Screwdriver-Operated Opposed Blade Damper – 1/2" spacing Lever-Operated Opposed Blade Damper – 1/3" spacing	Optional	Optional	—	Optional	—
Grid: Extruded aluminum adjustable curved blade air deflection grid	Optional	Optional	—	Optional	—
OBD with Grid: Screwdriver-Operated Opposed Blade Damper with extruded aluminum adjustable curved blade air deflection grid	Optional	Optional	—	Optional	—
GG: Gym Grade with welded blades and frame, and extra center margin supports	Optional	Optional	—	Optional	Optional
Short Bars: Core blades run parallel to shortest dimension	Optional	Optional	—	Optional	—
Special Shapes: Mitered and Custom Shapes diffusers (see website for more details) 	Optional	Optional	—	Optional	—
Radial Shapes: Radial shape diffusers (see website for more details)	—	—	—	—	—
Finished Flat End Caps	—	—	Standard	—	—
Butt Joints for continuous lengths	Optional	Optional	Optional	Optional	—
Fractional Dimensions	Optional	Optional	Optional	Optional	Optional

Frame Widths:

1" Frame

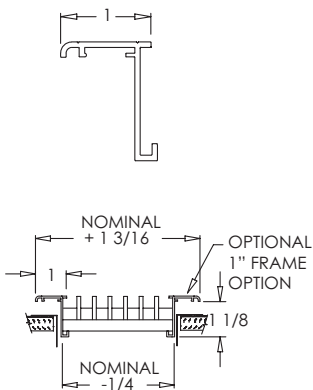

1 1/4" Frame

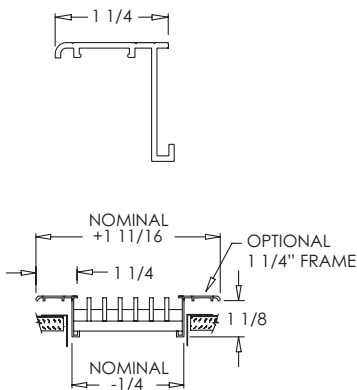

1 3/8" Frame

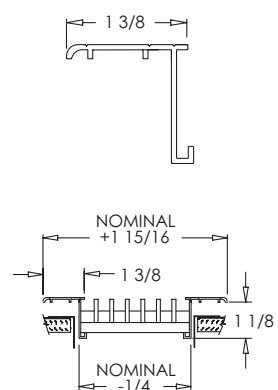

Field Adjustable



High Capacity



MRI Compatible



Expedited Service



Extended Leadtime

Product Options	Floor/Sill Mount	Removable Core with Flangeless Mounting Frame	Removable Core with Frame	1" Filter Grille Frame	2" Filter Grille Frame	Core only
1" Frame width	Optional	—	—	—	—	—
1 1/4" Frame width	Optional	—	—	—	—	—
1 3/8" Frame width	Standard	Standard	Standard	—	—	—
OBD: Screwdriver-Operated Opposed Blade Damper – 1/2" spacing Lever-Operated Opposed Blade Damper – 1/3" spacing	Optional	Optional	Optional	—	—	—
Grid: Extruded aluminum adjustable curved blade air deflection grid	Optional	Optional	Optional	—	—	—
OBD with Grid: Screwdriver-Operated Opposed Blade Damper with extruded aluminum adjustable curved blade air deflection grid	Optional	Optional	Optional	—	—	—
GG: Gym Grade with welded blades and frame, and extra center margin supports	Optional	Optional	Optional	Optional	Optional	Optional
Short Bars: Core blades run parallel to shortest dimension	Optional	—	—	Optional	Optional	Optional
Special Shapes: Mitered and Custom Shapes diffusers (see website for more details)	Optional	—	—	—	—	Optional
Radial Shapes: Radial shape diffusers (see website for more details)	—	—	—	—	—	Optional
Finished Flat End Caps	—	—	—	—	—	Optional
Butt Joints for continuous lengths	Optional	Optional	—	—	—	Optional
Fractional Dimensions	Optional	Optional	Optional	Optional	Optional	Optional

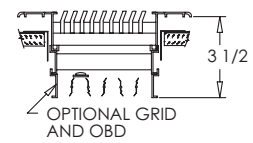
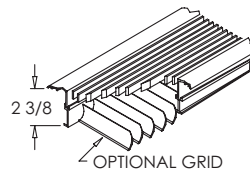
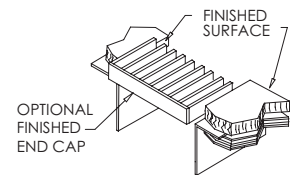
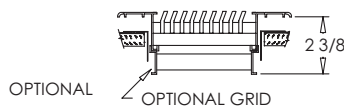
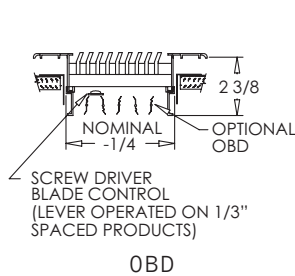

Butt Joints

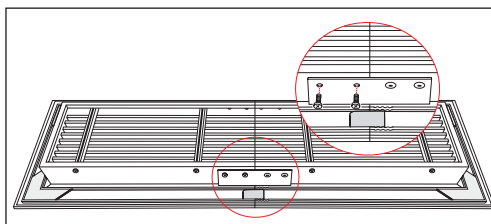
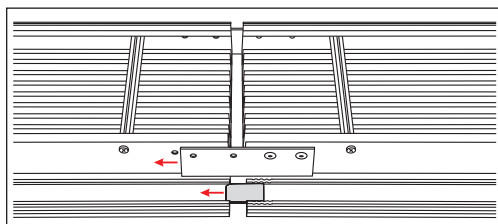
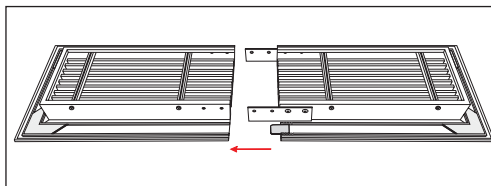
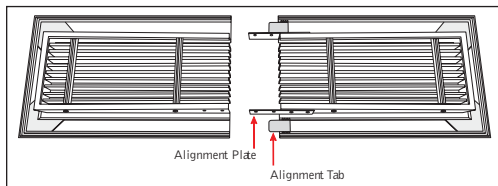

Butt joints shown apply to Mounting Type 1, 2, 4 and 7 only. Contact customer service for more information on butt joints available on other mounting types.

Drawings intended to illustrate butt joint components and operation. Drawings are not exact representation of the product depicted.

Performance Data: 1/2" Linear Bar Supply Diffuser

Size (Width In.)	Core Eff. Area (ft ²)	Neck Velocity (FPM) Velocity Pressure	300	400	500	600	700	800	900	1000
			0.006	0.010	0.015	0.021	0.029	0.038	0.048	0.065
1 1/2	0.070	CFM/ft	21	28	35	42	49	56	63	70
		NC	<20	<20	<20	20	25	25-30	30-35	35
		Throw	2 3 4	3 4.5 5.5	4 5 6	5 6 8	6 7 9	7 8 11	8 8.5 12.5	9 9.5 14.5
2	0.100	CFM/ft	30	40	50	60	70	80	90	100
		NC	<20	<20	<20	20	25	25-30	30-35	35
		Throw	3 4 5	4 5.5 6.5	6 7 9	7 8 11	9 10 13	9 10.5 14.5	10 12 18	11 13 20
2 1/2	0.130	CFM/ft	39	52	65	78	91	104	117	130
		NC	<20	<20	<20	20	25	25-30	30-35	35
		Throw	4 5 6	5 6.5 7.5	7 8 10	8 9 11.5	9 10.5 14.5	10 11.5 16	11 13 20	12 14 22
3	0.160	CFM/ft	48	64	80	96	112	128	144	160
		NC	<20	<20	<20	20	25	25-30	30-35	35
		Throw	5 5.5 6.5	6 7 9	8 9.5 11.5	9 10.5 14.5	11 13 17	12 14 19	14 16 23	15 17 26
3 1/2	0.190	CFM/ft	57	76	95	114	133	152	171	190
		NC	<20	<20	20	20	25	30	35	40
		Throw	6 6.5 7.5	7 8 10	9 10.5 12.5	10 11.5 16	12 14 19	13 15 21	15 17 25	16 18 27
4	0.220	CFM/ft	66	88	110	132	154	176	198	220
		NC	<20	<20	20	25	25	30	35	40
		Throw	6 7 8.5	8 9.5 11.5	10 11.5 14	11 13 18	13 15 21	16 18 24	16 18 26	17 19 29
5	0.280	CFM/ft	84	112	140	168	196	224	252	280
		NC	<20	<20	20	25	30	30-35	35-40	40
		Throw	7 8 10	9 10.5 12.5	11 13.5 17	12 14 19	15 17 22	17 19 26	17 20 31	20 23 34
6	0.339	CFM/ft	102	136	170	204	238	272	305	339
		NC	<20	<20	20	25	30	30	35-40	40
		Throw	8 8.5 10.5	10 11.5 14	12 14 17	15 17 22	16 18 24	19 22 30	21 24 36	23 26 39
8	0.459	CFM/ft	138	184	230	276	321	367	413	459
		NC	<20	<20	20	25	30	30-35	35-40	40
		Throw	9 10.5 12.5	12 13.5 17	13 15 18	16 18 24	19 22 29	21 24 33	22 26 40	25 30 45
10	0.579	CFM/ft	174	232	289	347	405	463	521	579
		NC	<20	20	25	25-30	30-35	30-35	40	45
		Throw	10 11.5 14	13 15 18	17 19 23	17 20 28	21 24 33	24 28 38	25 30 45	27 32 49
12	0.699	CFM/ft	210	280	349	419	489	559	629	699
		NC	<20	20	25	30	35	35-40	40	45
		Throw	12 13.5 17	14 16 20	19 22 26	21 24 33	23 27 36	26 31 41	26 31 47	31 37 56
14	0.819	CFM/ft	246	327	409	491	573	655	737	819
		NC	<20	20	25	30	35-40	40	45	45
		Throw	14 16 20	18 20 25	21 24 30	22 26 35	25 29 40	27 32 43	30 36 54	35 42 63

Performance Data: 1/2" Linear Bar Return Air Grilles

Size (Width In.)	Core Eff. Area (ft ²)	Neck Velocity (FPM) Velocity Pressure	300	400	500	600	700	800	900	1000
			0.006	0.032	0.048	0.070	0.092	0.120	0.130	0.140
1 1/2	0.070	CFM/ft	21	28	35	42	49	56	63	70
2	0.100	CFM/ft	30	40	50	60	70	80	90	100
2 1/2	0.130	CFM/ft	39	52	65	78	91	104	117	130
3	0.160	CFM/ft	48	64	80	96	112	128	144	160
3 1/2	0.190	CFM/ft	57	76	95	114	133	152	171	190
4	0.220	CFM/ft	66	88	110	132	154	176	198	220
5	0.280	CFM/ft	84	112	140	168	196	224	252	280
6	0.339	CFM/ft	102	136	170	204	238	272	305	339
8	0.459	CFM/ft	138	184	230	276	321	367	413	459
10	0.579	CFM/ft	174	232	289	347	405	463	521	579
12	0.699	CFM/ft	210	280	349	419	489	559	629	699
14	0.819	CFM/ft	246	327	409	491	573	655	737	819

Performance Notes:

- 1 All values in above table are per lineal foot
- 2 Additional performance data for sizes not listed is available at www.shoemakermfg.com
- 3 Throw values are measured in feet for terminal velocities of 100/75/50 FPM
- 4 Throw values are based on an active section of 1 foot long. To correct the throw for other lengths, use the table below.
- 5 Throw data is based on supply air and room air both at isothermal conditions
- 6 Effective core areas listed in chart are defined as the measurement of space between the blades actually being utilized by the air
- 7 Data obtained from tests conducted in accordance with ANSI/ASHRAE standard 70-2006

Throw Correction for Length

Active Length (feet)	1'	2'	3'	4'
Throw Correction	1 (published)	1.4	1.9	2.4

Performance Data: 1/3" Linear Bar Supply Diffuser

Size (Width In.)	Core Eff. Area (ft ²)	Neck Velocity (FPM) Velocity Pressure	300	400	500	600	700	800	900	1000
			0.006	0.010	0.015	0.021	0.029	0.038	0.048	0.065
1 1/2	0.065	CFM/ft	19	26	32	39	45	52	58	65
		NC	<20	<20	<20	20	25	25-30	30-35	35
		Throw (ft.)	2 2 3	2 3 4	4 4.5 5.5	4 4.5 6.5	5 6 8	6 7 9	7 7.5 11.5	8 9 13
2	0.090	CFM/ft	27	36	45	54	63	72	81	90
		NC	<20	<20	<20	20	25	25-30	30-35	35
		Throw (ft.)	3 4 5	4 4.5 5.5	5 6 8.5	6 7 9	7 8 11	8 9 13	8 9.5 14.5	10 11 17
2 1/2	0.115	CFM/ft	34	46	57	69	80	92	103	115
		NC	<20	<20	20	20	25	25-30	30-35	35
		Throw (ft.)	4 4.5 5.5	5 5.5 6.5	6 7 9	7 8 11	8 9.5 12.5	9 10 14	10 11 17	11 12.5 19
3	0.140	CFM/ft	42	56	70	84	98	112	126	140
		NC	<20	<20	20	20	25	25-30	30-35	35
		Throw (ft.)	4.5 5 6	6 6.5 7.5	7 8.5 10.5	8 9.5 12.5	9 10 14	11 12 16	11 12.5 19	12 14.5 22
3 1/2	0.165	CFM/ft	49	66	82	99	115	132	148	165
		NC	<20	<20	20	20	25	30	35	35-40
		Throw (ft.)	4.5 5 6	6 7 9	8 9 11	9 10 13	10 11 15	12 13 17	12 14 21	14 16 24
4	0.190	CFM/ft	57	76	95	114	133	152	171	190
		NC	<20	<20	20	25	25	30	35	40
		Throw (ft.)	5 5.5 6.5	6 7 9	9 10 12	10 11.5 16	11 13 18	13 15 21	14 16 24	15 17 26
5	0.240	CFM/ft	72	96	120	144	168	192	216	240
		NC	<20	<20	20	20	25	30	35	40
		Throw (ft.)	6 7 8.5	7 8 10	10 11 13	11 13 17	12 14 19	14 16 21	15 17 25	16 18 28
6	0.289	CFM/ft	87	116	145	174	203	232	261	289
		NC	<20	<20	20	25	25-30	30	35-40	40
		Throw (ft.)	6 7 9	9 10 12	11 12.5 16	12 14 18	14 16 21	15 17 23	16 18 27	18 20 31
8	0.389	CFM/ft	117	156	195	234	273	311	350	389
		NC	<20	<20	20	25	30	30-35	35-40	40
		Throw (ft.)	7 8 10	10 11 14	12 14 17	13 15 21	15 17 23	16 19 26	18 20 31	21 24 36
10	0.489	CFM/ft	147	196	245	293	342	391	440	489
		NC	<20	20	25	25-30	30	30-35	40	40
		Throw (ft.)	10 11 13	11 12 15	14 16 20	15 17 23	17 19 26	19 22 29	21 24 36	25 29 43
12	0.589	CFM/ft	177	236	294	353	412	471	530	589
		NC	<20	20	25	30	35	40	40	45
		Throw (ft.)	10 11.5 14	11 12.5 16	16 18 22	17 20 27	20 23 31	23 27 36	25 29 43	26 31 47
14	0.689	CFM/ft	207	276	344	413	482	551	620	689
		NC	<20	20	25	30	35-40	40	45	45
		Throw (ft.)	11 12 15	12 13.5 17	17 19 24	19 22 29	23 27 36	25 29 40	26 30 45	28 34 50

Performance Data: 1/3" Linear Bar Return Air Grilles

Size (Width In.)	Core Eff. Area (ft ²)	Neck Velocity (FPM) Velocity Pressure	300	400	500	600	700	800	900	1000
			0.006	0.032	0.048	0.070	0.092	0.120	0.130	0.140
1 1/2	0.065	CFM/ft	19	26	32	39	45	52	58	65
2	0.090	CFM/ft	27	36	45	54	63	72	81	90
2 1/2	0.115	CFM/ft	34	46	57	69	80	92	103	115
3	0.140	CFM/ft	42	56	70	84	98	112	126	140
3 1/2	0.165	CFM/ft	49	66	82	99	115	132	148	165
4	0.190	CFM/ft	57	76	95	114	133	152	171	190
5	0.240	CFM/ft	72	96	120	144	168	192	216	240
6	0.289	CFM/ft	87	116	145	174	203	232	261	289
8	0.389	CFM/ft	117	156	195	234	273	311	350	389
10	0.489	CFM/ft	147	196	245	293	342	391	440	489
12	0.589	CFM/ft	177	236	294	353	412	471	530	589
14	0.689	CFM/ft	207	276	344	413	482	551	620	689

Performance Notes:

- 1 All values in above table are per lineal foot
- 2 Additional performance data for sizes not listed is available at www.shoemakerfmfg.com
- 3 Throw values are measured in feet for terminal velocities of 100/75/50 FPM

- 4 Throw values are based on an active section of 1 foot long. To correct the throw for other lengths, use the table below
- 5 Throw data is based on supply air and room air both at isothermal conditions

- 6 Effective core areas listed in chart are defined as the measurement of space between the blades actually being utilized by the air
- 7 Data obtained from tests conducted in accordance with ANSI/ASHRAE standard 70-2006

Throw Correction for Length

Active Length (feet)	1'	2'	3'	4'
Throw Correction	1 (published)	1.4	1.9	2.4

LINEAR SLOT DIFFUSER SERIES



LSD Concealed Mount Supply Diffuser with 2 Slots and Flanged End Caps



LSD Surface Mount Return with 2 Slots and Flanged End Caps



LSD T-Bar Narrow Frame Supply with 3 Slots and Flat End Caps

LSD Series

Standard Features:

- High quality high performance linear slot diffuser
- Designed for cooling or heating; supply or return applications
- Adjustable black extruded aluminum clam shell pattern controller allows full 180° adjustment of airflow on supply model
- All mounting types available in lengths up to 12'*
- * Lengths may vary for shipping considerations
- Rust resistant pre-coat with durable powder finish
- Soft White

Slot Options:

- Available in 1/2", 3/4" and 1" slot widths
- Available in 1 slot up to 8 slots
- Return (without pattern controller)

MODEL: LSD-R

Additional Options:

- Rigid fiberglass plenum allows for multiple locations of field installed spin-in collars up to 12" (collar provided by others)
- Mitered corners
- All additional options reference chart



Mounting Types:

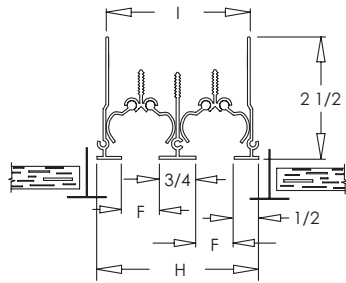

TYPE 1
T-BAR NARROW FRAME

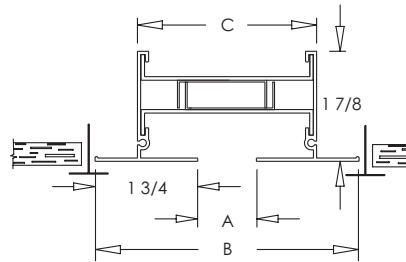

TYPE 2
T-BAR WIDE FRAME

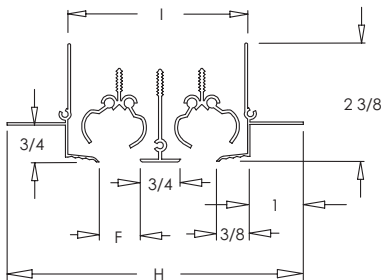

TYPE 3
TAPE AND MUD

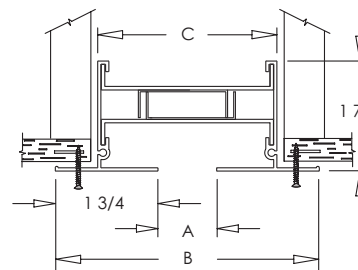

TYPE 4
SURFACE MOUNT



Field Adjustable



High Capacity



MRI Compatible



Expedited Service



Extended Leadtime

LINEAR SLOT DIFFUSER SERIES

Mounting Types:

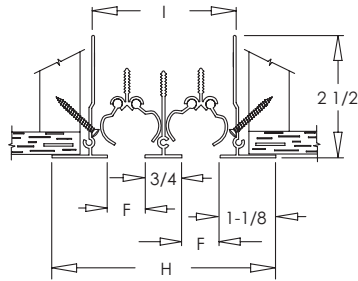

TYPE 5
CONCEALED MOUNT

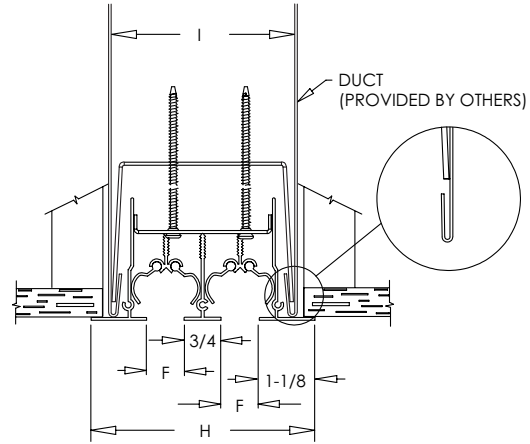

TYPE 6

Dimensions in Inches

Number of Slots	Slot Width (F)	Overall Width by Frame Type (H)			Width of Back without Plenum by Frame Type (I)	
		1	2, 4, 5, & 6	3	1, 2, 3, 4, & 5	6 (Duct Width)
1 SLOT	1/2	1 1/2	2 3/4	3 1/4	1 1/2	1 3/4
	3/4	1 3/4	3	3 1/2	1 3/4	2
	1	2	3 1/4	3 3/4	2	2 1/4
2 SLOT	1/2	2 3/4	4	4 1/2	2 3/4	3
	3/4	3 1/4	4 1/2	5	3 1/4	3 1/2
	1	3 3/4	5	5 1/2	3 3/4	4
3 SLOT	1/2	4	5 1/4	5 3/4	4	1 1/4
	3/4	4 3/4	6	6 1/2	4 3/4	5
	1	5 1/2	6 3/4	7 1/4	5 1/2	5 3/4
4 SLOT	1/2	5 1/4	6 1/2	7	5 1/4	5 1/2
	3/4	6 1/4	7 1/2	8	6 1/4	6 1/2
	1	7 1/4	8 1/2	9	7 1/4	7 1/2

Dimensional Notes:

- Mounting Types 1, 2, & 3
 - Length ID: Nominal -1/4"
- Mounting Types 4, 5, & 6
 - Length ID: Nominal -1/4"
 - Length OD: Nominal +1 1/4"
- Width of back with plenum is equal to Dimension I + 1/2". Plenum not available on mounting type 6.

LINEAR SLOT DIFFUSER SERIES

Product Options	T-Bar Mount with Narrow Frame	T-Bar Mount with Wide Frame	Tape and Mud Mount	Surface Mount	Concealed Mount	Duct Bracket Mount
Plenum: Rigid fiberglass plenum allows for multiple locations of field installed spin in collars up to 12" (collar provided by others)	Optional	Optional	Optional	Optional	Optional	—
Flat End Caps	Standard	Standard	Standard	Optional	Optional	Optional
Flanged End Caps	Optional	Optional	—	Standard	Standard	Standard
Butt Joints or mitered corners for continuous lengths	Optional	Optional	Optional	Optional	Optional	Optional
Fractional Dimensions	Optional	Optional	Optional	Optional	Optional	Optional

Plenum:

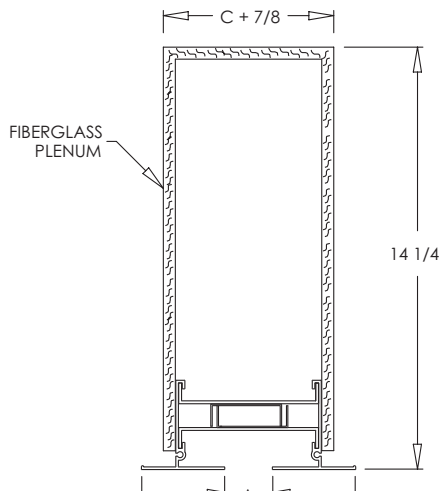

End Caps:

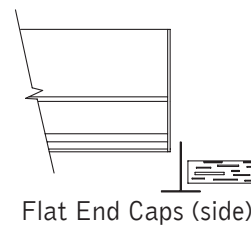
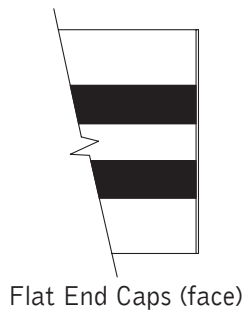
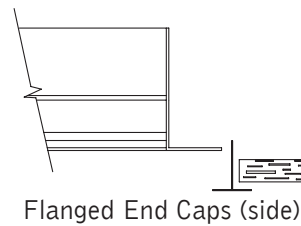
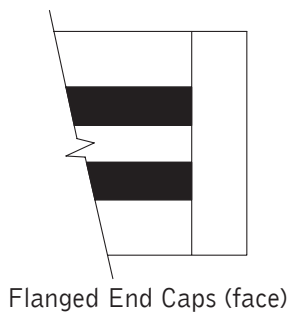

Field Adjustable



High Capacity



MRI Compatible



Expedited Service



Extended Leadtime

Performance Data: Linear Slot Diffuser (LSD) Series

# of Slots	Width	Core Eff. Area (ft ²)	Neck Velocity (FPM) Total Pressure	300	400	500	600	700	800	900	1000
				0.006	0.015	0.035	0.075	0.115	0.155	0.170	0.225
1	1/2"	0.040	CFM/ft.	12	16	20	24	28	32	36	40
			NC	<20	<20	<20	<20	20-25	25-30	30-35	35-40
			Throw (ft.)	2	2.5 3.5	5 5.5 6.5	7 8 10	8 9.5 12.5	9 10 14	10 12 16	11 13 18
2	1/2"	0.079	CFM/ft.	24	32	40	48	55	63	71	79
			NC	<20	<20	<20	20-25	25-30	30-35	35-40	40
			Throw (ft.)	3	3.5 4.5	6 7 9	10 11.5 14.5	12 13.5 18	13 14.5 20	14 16 22	14 18 24
3	1/2"	0.119	CFM/ft.	36	48	59	71	83	95	107	119
			NC	<20	<20	<20	20-25	30-35	35-40	35-40	40-45
			Throw (ft.)	4	4.5 5.5	8 9 11	11 13.5 17	14 16 22	16 18 24	18 20 27	18 21 30
4	1/2"	0.158	CFM/ft.	48	63	79	95	111	127	143	158
			NC	<20	<20	<20	20-25	30-35	35-40	40-45	40-45
			Throw (ft.)	6	6.5 7.5	10 11 13	14 16 20	17 19 25	18 21 29	20 23 31	21 24 35

# of Slots	Width	Core Eff. Area (ft ²)	Neck Velocity (FPM) Total Pressure	300	400	500	600	700	800	900	1000
				0.004	0.015	0.035	0.075	0.115	0.155	0.170	0.225
1	3/4"	0.059	CFM/ft.	18	24	30	36	42	48	53	59
			NC	<20	<20	<20	<20	20-25	25-30	30-35	35-40
			Throw (ft.)	2	2.5 3.5	5 5.5 6.5	8 9 11	9 10 14	11 12 16	11 13 17	12 14 19
2	3/4"	0.119	CFM/ft.	36	48	59	71	83	95	107	119
			NC	<20	<20	<20	20-25	25-30	30-35	35-40	40-45
			Throw (ft.)	3	3.5 4.5	7 8 10	11 12.5 15.5	13 14.5 20	14 16 22	16 18 24	16 18 28
3	3/4"	0.178	CFM/ft.	53	71	89	107	125	143	160	178
			NC	<20	<20	<20	20-25	25-30	30-35	35-40	40-45
			Throw (ft.)	5	5.5 6.5	9 10 12	14 15.5 19	16 18 24	18 20 27	19 22 30	20 22 34
4	3/4"	0.238	CFM/ft.	71	95	119	143	166	190	214	238
			NC	<20	<20	<20	20-25	30-35	35-40	40-45	45-50
			Throw (ft.)	6	6.5 7.5	10 11.5 14.5	15 17 21	18 20 28	20 23 31	23 26 35	23 26 38

# of Slots	Width	Core Eff. Area (ft ²)	Neck Velocity (FPM) Total Pressure	300	400	500	600	700	800	900	1000
				0.004	0.015	0.035	0.075	0.115	0.155	0.170	0.225
1	1"	0.079	CFM/ft.	24	32	40	48	55	63	71	79
			NC	<20	<20	<20	20-25	25-30	30-35	35-40	40-45
			Throw (ft.)	3	3.5 4.5	6 7 9	10 11 13	11 12 16	11 13 17	13 14.5 20	12 14.5 22
2	1"	0.158	CFM/ft.	48	63	79	95	111	127	143	158
			NC	<20	<20	<20	25-30	30-35	35-40	40-45	45-50
			Throw (ft.)	4	4.5 5.5	9 10 12	13 14.5 18	14 16 22	17 19 25	18 20 28	19 21 31
3	1"	0.238	CFM/ft.	71	95	119	143	166	190	214	238
			NC	<20	<20	20-25	25-30	35-40	40-45	45-50	>50
			Throw (ft.)	5	6.5 7.5	10 11.5 14.5	16 18 22	18 20 28	20 23 31	22 25 33	23 26 38
4	1"	0.317	CFM/ft.	95	127	158	190	222	253	285	317
			NC	<20	<20	20-25	30-35	35-40	40-45	45-50	>50
			Throw (ft.)	6	7 9	12 13.5 17	19 21 25	21 24 32	22 25 36	25 29 39	25 29 43

Performance Notes:

- 1 All values in above table are per lineal foot
- 2 Additional performance data for sizes not listed is available at www.shoemakermg.com
- 3 Throw values are measured in feet for terminal velocities of 100/75/50 FPM

- 4 Throw values are based on an active section of 1 foot long. To correct the throw for other lengths, use the table below.
- 5 Throw data is based on supply air and room air both at isothermal conditions

- 6 Effective core areas listed in chart are defined as the measurement of space between the blades actually being utilized by the air
- 7 Data obtained from tests conducted in accordance with ANSI/ASHRAE standard 70-2006

Throw Correction for Length

Active Length (feet)	1'	2'	3'	4'
Throw Correction	1 (published)	1.4	1.9	2.4

Performance Data: Linear Slot Diffuser Return (LSD-R) Series

# of Slots	Width	Core Eff. Area (ft ²)	Neck Velocity (FPM) Total Pressure	300	400	500	600	700	800	900	1000
				0.004	0.015	0.035	0.075	0.115	0.155	0.170	0.225
1	1/2"	0.042	CFM/ft.	13	17	21	25	29	33	38	42
			NC	<20	<20	<20	20	25	30-35	35-40	40-45
2	1/2"	0.083	CFM/ft.	25	33	42	50	58	67	75	83
			NC	<20	<20	<20	20-25	25-30	35-40	40-45	45-50
3	1/2"	0.125	CFM/ft.	38	50	63	75	88	100	113	125
			NC	<20	<20	<20	25-30	30-35	35-40	40-45	45-50
4	1/2"	0.167	CFM/ft.	50	67	83	100	117	133	150	167
			NC	<20	<20	20-25	25-30	30-35	35-40	40-45	45-50

# of Slots	Width	Core Eff. Area (ft ²)	Neck Velocity (FPM) Total Pressure	300	400	500	600	700	800	900	1000
				0.004	0.015	0.035	0.075	0.115	0.155	0.170	0.225
1	3/4"	0.063	CFM/ft.	19	25	31	38	44	50	56	63
			NC	<20	<20	<20	20-25	25-30	30-35	35-40	40-45
2	3/4"	0.125	CFM/ft.	38	50	63	75	88	100	113	125
			NC	<20	<20	<20	25-30	30-35	35-40	40-45	45-50
3	3/4"	0.188	CFM/ft.	56	75	94	113	131	150	169	188
			NC	<20	<20	20-25	30-35	35-40	40-45	45-50	50
4	3/4"	0.250	CFM/ft.	75	100	125	150	175	200	225	250
			NC	<20	<20	20-25	30-35	35-40	40-45	45-50	>50

# of Slots	Width	Core Eff. Area (ft ²)	Neck Velocity (FPM) Total Pressure	300	400	500	600	700	800	900	1000
				0.004	0.015	0.035	0.075	0.115	0.155	0.170	0.225
1	1"	0.083	CFM/ft.	25	33	42	50	58	67	75	83
			NC	<20	<20	<20	20-25	25-30	35-40	40-45	45-50
2	1"	0.167	CFM/ft.	50	67	83	100	117	133	150	167
			NC	<20	<20	20-25	25-30	30-35	35-40	40-45	45-50
3	1"	0.250	CFM/ft.	75	100	125	150	175	200	225	250
			NC	<20	<20	20-25	30	35	35-40	40-45	45-50
4	1"	0.333	CFM/ft.	100	133	167	200	233	267	300	333
			NC	<20	<20	25	30-35	35-40	40	40-45	50

Performance Notes:

1 All values in above table are per lineal foot
 2 Additional performance data for sizes not listed is available at www.shoemakerfmfg.com

3 Effective core areas listed in chart are defined as the measurement of space between the blades actually being utilized by the air

4 Data obtained from tests conducted in accordance with ANSI/ASHRAE standard 70-2006



Field Adjustable



High Capacity



MRI Compatible



Expedited Service



Extended Leadtime

AIR BAR DIFFUSERS



Air Bar Surface Mount
with 1 Slot and Flanged End Caps



Air Bar T-Bar Wide Frame
with 2 Slots, Flat End Caps and Plenum



Air Bar Tape and Mud 1 Slot
BEFORE INSTALL



Air Bar Tape and Mud 1 Slot
AFTER INSTALL

Controllers:

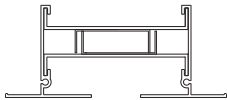

Air Gate Controller

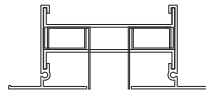

Jet Pair Controllers

Mounting Types:

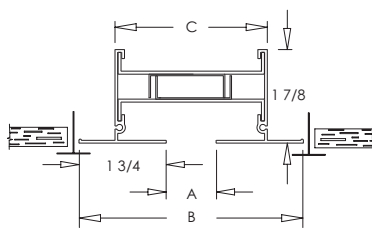

TYPE 2
T-BAR WIDE FRAME

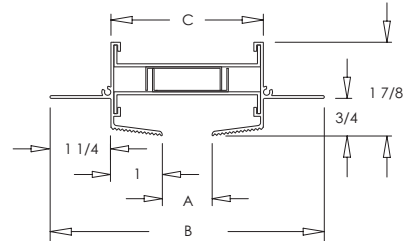

TYPE 3
TAPE AND MUD

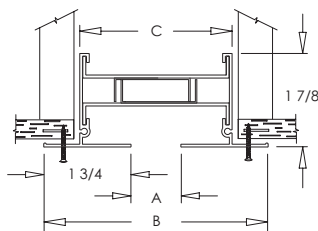

TYPE 4
SURFACE MOUNT

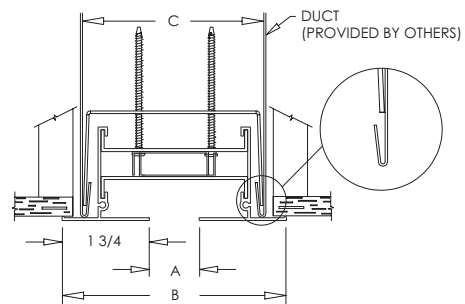

TYPE 6
DUCT BRACKET MOUNT

Note: See website for performance data on the Air Bar series products

LAB/LJP Series

Standard Features:

- Air bar diffuser with versatile airflow capability
- Allows for higher volume air flow while minimizing pressure loss
- For low and high sidewalls and ceiling; heating and cooling applications
- Engineered for performance and seamless integration with architectural elements of the space
- Single slot with adjustable controllers for directional air volume control
- Adjustable controllers come in 2' sections
- Made in single sections up to 12' in length*
* Lengths may vary for shipping considerations
- All interior controllers are steel and painted black
- Rust resistant pre-coat with durable powder finish
- Soft White

Slot Options:

- Available in 1", 1.5", 2", 2.5" and 3" slot widths
- Available in 1 and 2 slot configurations

Pattern Controllers

- Air Gate Controllers – Split 2-piece Air Gate Controllers
MODEL: LAB
- Jet Pair Controllers – Split 2-piece Jet Pair Controllers, extremely versatile for high ceiling and sidewall applications
MODEL: LJP



AIR BAR DIFFUSER SERIES

Product Options	T-Bar Mount with Wide Frame	Tape and Mud Mount	Surface Mount	Duct Bracket Mount
Plenum: Rigid fiberglass plenum allows for multiple locations of field installed spin in collars up to 12" (collar provided by others)	Optional	Optional	Optional	Optional
Flat End Caps	Standard	Standard	—	Optional
Flanged End Caps	Optional	—	Standard	Standard
Butt Joints or mitered corners for continuous lengths	Optional	Optional	Optional	Optional
Fractional Dimensions	Optional	Optional	Optional	Optional

End caps:

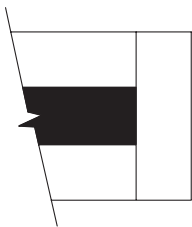

Flanged End Caps (face)

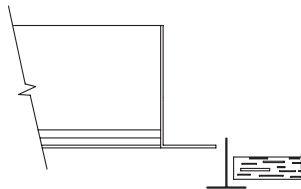

Flanged End Caps (side)



Flat End Caps (face)

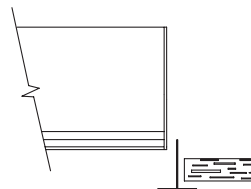

Flat End Caps (side)

Plenum:

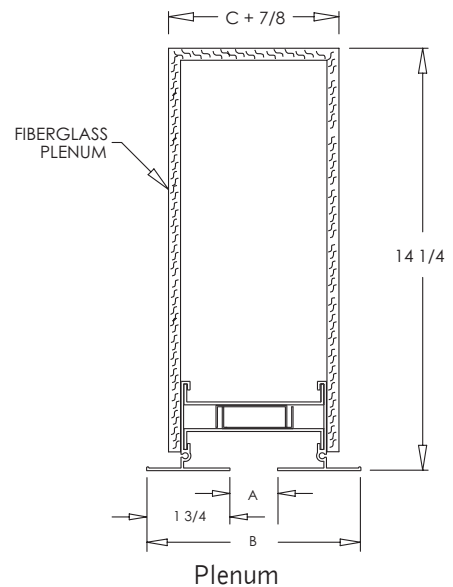

Dimensions in Inches

Number of Slots	Slot Width (A)	Overall Width by Frame Type (B)		Width of Back without Plenum by Frame Type (C)	
		2, 4, 6	3	2, 4, 6	3
1	1	4 1/2	5 1/2	3 1/8	3
	1 1/2	5	6	3 5/8	3 1/2
	2	5 1/2	6 1/2	4 1/8	4
	2 1/2	6	7	4 5/8	4 1/2
	3	6 1/2	7 1/2	5 1/8	5
2	1	7 1/2	8 1/2	6	6
	1 1/2	8 1/2	9 1/2	7	7
	2	9 1/2	10 1/2	8	8
	2 1/2	10 1/2	11 1/2	9	9
	3	11 1/2	12 1/2	10	10

Dimensional Notes:

- Mounting Types 4 & 6:
 - Length ID: Nominal - 1/4"
 - Length OD: Nominal + 1 3/4"

- Mounting Types 2 & 3:
 - Length ID: Nominal - 1/4"

- Width of back with plenum is equal to Dimension C + 7/8". Plenum not available on mounting type 6.



Field Adjustable



High Capacity



MRI Compatible



Expedited Service









Extended Leadtime

OVERVIEW

Shoemaker offers a variety of dampers and louvers that meet a wide range of performance needs while providing aesthetic appeal. The damper line includes air control, face and by-pass, pressure relief, and backdraft models. The outside air louvers are industrial quality extruded aluminum and include drainable, rain and wind resistant models with many blade, spacing, material and shape options. Shoemaker also offers several options of combination damper / louver products.

Product Key

The product key located on the bottom of each page uses symbols to note options, features and services that are found repeatedly throughout this section of the catalog:

- 
STANDARD COLOR
 Rust resistant pre-coat with durable powder coat paint finish in Soft White or Driftwood Tan.
- 
DESIGNER COLOR
 Rust resistant pre-coat with durable powder coat paint finish available in custom colors. See appendix or website for list of available colors. Additional charges apply.
- 
ALUMINUM PAINT
 Closely replicates a cleaned aluminum finish with the added benefits of our powder coat painting process. Additional charges apply.
- 
MILL FINISH
 Raw (no finish), factory cleaned.
- 
EXPEDITED SERVICES PROGRAM
 Available with Expedited Service Program, products manufactured faster than standard lead times. Additional charges apply. See website for program details.
- 
EXPEDITED SERVICES PROGRAM – CONTACT FACTORY
 Contact factory for Expedited Service Program availability, products manufactured faster than standard lead times. Additional charges apply. See website for program details.
- 
EXTENDED LEADTIME
 Product not available in our standard lead time. Contact customer service for lead time quote.

AIR CONTROL DAMPERS



3000 P Series Parallel Blade Air Control Damper

Standard Features:

- Parallel blade operation designed for volume control
- 16 gauge galvanized channel frame
- Galvanized blades are vee stiffened for extra strength and stability
- Blades pivot on high temperature nylon bushings
- 1/2" square zinc plated steel pivot pins
- 1/2" square zinc plated steel adjustable operating shaft, extends up to 4" beyond the air control frame
- Single blades on dampers with a height of 10" or less
- Blades run parallel to first dimension given
- Blades must be operated on horizontal plane
- Minimum size 6" x 6"
- Maximum one piece size 48" x 48"
- Galvanized Finish

Options:

- Low Leak Package: features stainless steel jamb seals, blade to blade neoprene seals, and 3% maximum leakage with a pressure differential 3" W.C.

MODEL: 3000 PLL

- Air control damper with aluminum airfoil blades. The airfoil blade design provides excellent pressure drop performance over standard blade design.

MODEL: 3000AF-P



- Double blades on dampers with a height of 8" or 10" (i.e. 3000 P-8 x 8 DB.)

- 12 gauge galvanized construction
- Extended square operating shaft (extending 7 1/2" beyond the air control frame)
- Round operating shaft (1/2" diameter)
- Spring opening damper
- Spring closing damper
- Oil impregnated bronze bearings
- Outside mounting flange
- Direct mount damper motors (field installed.) Mounts on operating shaft. Standard operating shaft position is bottom right, back side of damper blades when viewed from face of the product.
- Fractional and exact O.D. dimensions

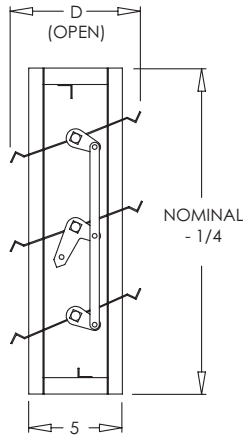

3000-P

3000 P Dimensions

3000 P		3000 P		3000 P	
Height	Open Depth (D)	Height	Open Depth (D)	Height	Open Depth (D)
6"	5"	18"	8"	34"	7"
8"	7 1/8"	20"	6 1/2"	36"	8"
8" DB.	5 1/2"	22"	7"	38"	6 1/2"
10"	9 1/8"	24"	8"	40"	7"
10" DB.	5 1/2"	26"	6 1/2"	42"	8"
12"	5 3/4"	28"	7"	44"	6 1/2"
14"	6"	30"	8"	46"	7"
16"	7"	32"	6 1/2"	48"	8"

Note: Add 1 3/8" to Open Depth (D) for Low Leak Package



AIR CONTROL DAMPERS



3000-OBD Series Opposed Blade Air Control Damper

Standard Features:

- Opposed blade operation designed for precise volume control
- 16 gauge galvanized channel frame
- Galvanized blades are vee stiffened for extra strength and stability
- Blades pivot on high temperature nylon bushings
- 1/2" square zinc plated steel pivot pins
- 1/2" square zinc plated steel adjustable operating shaft, extends up to 4" beyond the air control frame
- Blades run parallel to first dimension given
- Blades must be operated on horizontal plane
- Minimum size 8" x 8"
- Maximum one piece size 48" x 48"
- Galvanized Finish

Options:

- Low Leak Package: features stainless steel jamb seals, blade to blade neoprene seals, and 3% maximum leakage with a pressure differential 3" W.C.

MODEL: 3000-OBDLL

- Air control damper with aluminum airfoil blades. The airfoil blade design provides excellent pressure drop performance over standard blade design.

MODEL: 3000AF-OBD

- 12 gauge galvanized construction
- Extended square operating shaft (extending 7 1/2" beyond the air control frame)
- Round operating shaft (1/2" diameter)
- Spring opening damper
- Spring closing damper
- Oil impregnated bronze bearings
- Outside mounting flange
- Direct mount damper motors (field installed). Mounts on operating shaft. Standard operating shaft position is bottom right, back side of damper blades when viewed from face of the product.
- Fractional and exact O.D. dimensions

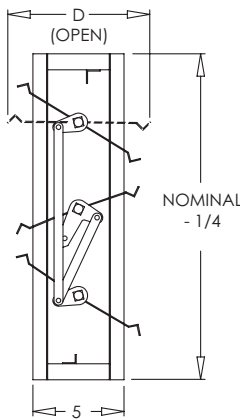

3000-OBD

3000 OBD Dimensions

3000 OBD		3000 OBD		3000 OBD	
Height	Open Depth (D)	Height	Open Depth (D)	Height	Open Depth (D)
8"	5"	22"	7"	36"	8"
10"	5 1/2"	24"	8"	38"	6 1/2"
12"	5 3/4"	26"	6 1/2"	40"	7"
14"	6"	28"	7"	42"	8"
16"	7"	30"	8"	44"	6 1/2"
18"	8"	32"	6 1/2"	46"	7"
20"	6 1/2"	34"	7"	48"	8"

Note: Add 1 3/8" to Open Depth (D) for Low Leak Package



Expedited Service



Expedited Service – Contact Factory



Extended Leadtime

AIR CONTROL DAMPERS



3000P-R Series Round Air Control Damper

Standard Features:

- Round damper designed for volume control
- 16 gauge galvanized channel frame
- Single galvanized blade is vee stiffened for extra strength and stability
- Blades pivot on high temperature nylon bushings
- 1/2" square zinc plated steel pivot pins
- 1/2" square zinc plated steel adjustable operating shaft, extends up to 4" beyond the air control frame
- Minimum size 5"
- Maximum size 24"
- Galvanized Finish

Options:

- Low Leak Package: features silicone caulk seal
MODEL: 3000P-RLL
- Extended square operating shaft (extending 7 1/2" beyond the air control frame)
- Round operating shaft (1/2" diameter)
- Spring opening damper
- Spring closing damper
- Oil impregnated bronze bearings
- Direct mount damper motor (field installed). Mounts on operating shaft.
- Fractional and exact O.D. dimensions

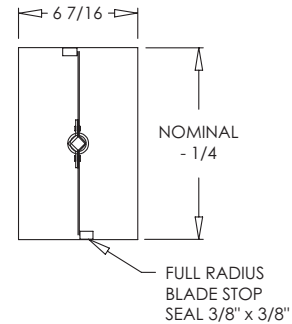
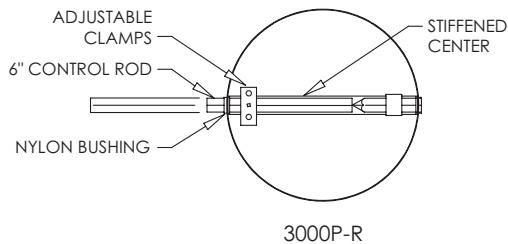

FACE AND BY-PASS DAMPERS

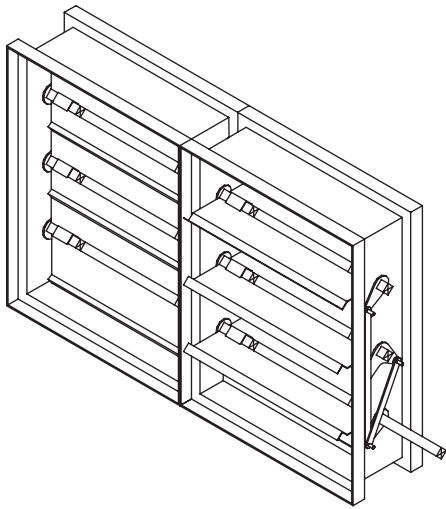

3100 Series Face and By-Pass Dampers

Standard Features:

- 16 gauge channel frame and blades
- Galvanized blades are vee stiffened for extra strength and stability
- Blades pivot on high temperature nylon bushings
- 1/2" square zinc plated steel pivot pins
- 1/2" square zinc plated steel adjustable operating shaft, extends up to 4" beyond the air control frame. Common control rod opens and closes dampers simultaneously.
- 1/2" square steel pivot pins and rod
- Two dampers assembled together enabling one to open while the other closes
- Galvanized Finish

Mounting Options:

- Right Angle
MODEL: 3101
- Top to Bottom
MODEL: 3102
- Side to Side
MODEL: 3103

Blade Configuration:

- Parallel Blades
MODELS: 3101-P, 3102-P, 3103-P
- Opposed Blades
MODELS: 3101-0BD, 3102-0BD, 3103-0BD

Options:

- Low Leak Package: features stainless steel jamb seals, blade to blade neoprene seals, and 3% maximum leakage with a pressure differential 3" W.C.
MODELS: 3101-LL, 3102-LL, 3103-LL
- Bronze bearings
- Round operating shaft (1/2" diameter)
- Fractional and exact O.D. dimensions
- Direct mount damper motor (field installed). Mounts on operating shaft.

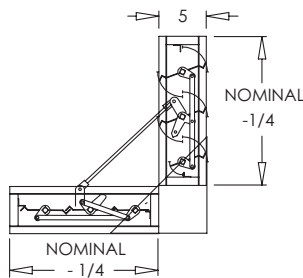

3101
RIGHT ANGLE

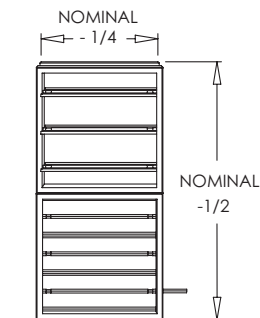

3102
TOP TO BOTTOM

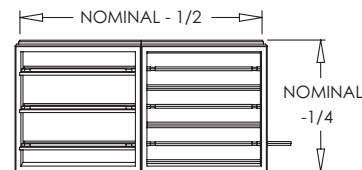

3103
SIDE TO SIDE



PRESSURE RELIEF DAMPERS



3510 Series Vertical Mount Pressure Relief Damper

Standard Features:

- Designed to open in negative or positive pressures for intake or exhaust air
- All aluminum construction
- Blade to blade linkage
- Foam tape sealed blade edges to dampen noise
- Single blades on dampers with a height of 10" or less
- Blades run parallel to first dimension given
- 1/4" pivot pins in nylon bearings
- Minimum size 6" x 6"
- Maximum size 24" x 24"
- Mill Finish

Options:

- Adjustable counter balance arms mounted to center of blades. Adjustable weights can be positioned along arm for various opening pressures. (Available only on dampers with multiple blades.)
- Mounting flange
- Sleeves (Contact factory for details)
- Fractional and exact O.D. dimensions
- Horizontal mount (air up) pressure relief
MODEL: 3520
- Horizontal mount (air down) pressure relief
MODEL: 3530

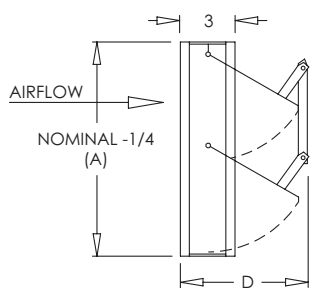

3510

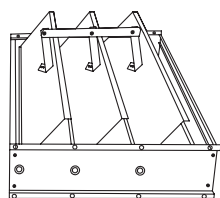

3520

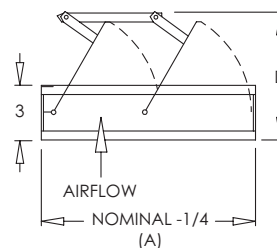

3520

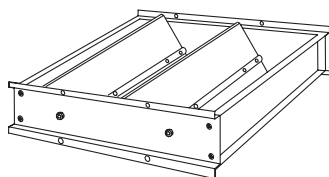

3530

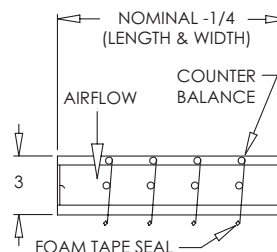

3530

3510/3520 Dimensions

Dimension (A)	Open Depth (D)	Dimension (A)	Open Depth (D)	Dimension (A)	Open Depth (D)
6"	6 1/4"	12"	7 7/8"	18"	8 5/8"
8"	8 1/4"	14"	8 3/4"	20"	7 3/4"
10"	10 1/4"	16"	7 1/2"	24"	8 1/8"



BACKDRAFT DAMPERS



3550 Series Vertical Mount Backdraft Damper

Standard Features:

- Dampers are opened by air pressure differential and closed by gravity
- 16 gauge channel frame
- Galvanized blades are 26 gauge and vee stiffened for extra strength and stability
- Out of airstream linkage
- Single blades on dampers with a height of 10" or less
- Blades run parallel to first dimension given
- Adjustable counter balance arms mounted to center of blades. Adjustable weights can be positioned along arm for various opening pressures. (Only on dampers with multiple blades.)
- Square steel pivot pins in nylon bushings
- Foam tape sealed blade edges to dampen noise
- Minimum size 6" x 6"
- Maximum size 48" x 48"
- Galvanized Finish

Options:

- Double blades on dampers with a height of 8" or 10" (i.e. 3550-8 x 8 DB.)
- Outside mounting flange
- Bronze bearings
- Sleeves (Contact factory for details)
- Fractional and exact O.D. dimensions
- Horizontal mount air up configuration
MODEL: 3560
- Horizontal mount air down configuration
MODEL: 3570
- Round design
MODEL: 3580

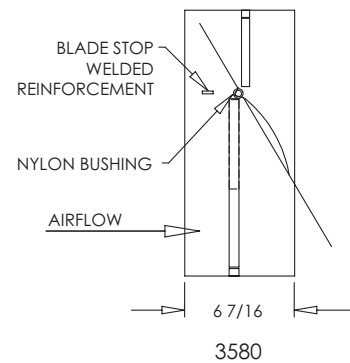
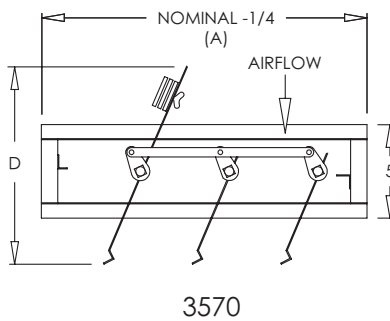
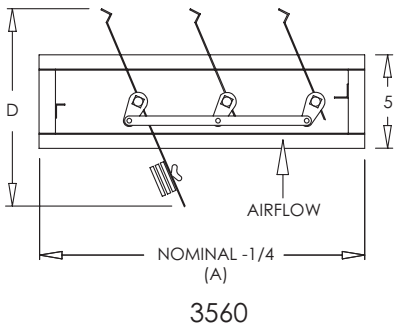
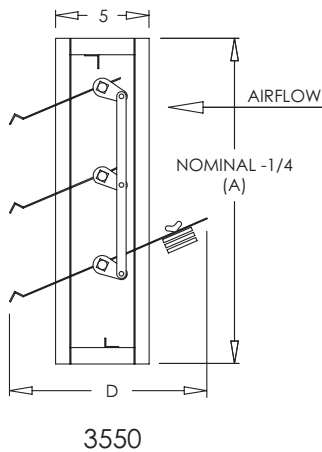

3550/3560/3570 Dimensions

Height	Open Depth (D)
6"	11 5/8"
8"	13 5/8"
8" DB.	11 5/8"
10"	15 5/8"
10" DB.	11 5/8"
12"	11 5/8"
14"	12 1/8"
16"	13 3/8"

Height	Open Depth (D)
18"	14 3/8"
20"	12 7/8"
22"	13 3/8"
24"	14 3/8"
26"	12 7/8"
28"	13 3/8"
30"	14 3/8"
32"	12 7/8"

Height	Open Depth (D)
34"	13 3/8"
36"	14 3/8"
38"	12 7/8"
40"	13 3/8"
42"	14 3/8"
44"	12 7/8"
46"	13 3/8"
48"	14 3/8"

DAMPER SLEEVES

Sleeves for Dampers: 3000 & 3500

Standard Features:

- Sleeve Type A: Square or rectangular
- Standard sleeve length 18"
- 20 gauge galvanized steel
- Mill Finish

Options:

- Gauges: 14 through 22 ga.
- Aluminum sleeve (available only on 3000 series)
- Access door installed
- Retaining angles
- Available in sleeve lengths 6" through 20"
- Fractional and exact O.D. dimensions

Sleeve Types:

- Type B: Out-of-Airstream
- Type C: Square or rectangular with flange (Note: When ordered with 3500 series dampers must specify whether flange is on intake or exhaust side of damper)
- Type D: Square or rectangular with round collar (Note: Round collar must be 2" smaller than square sleeve dimension i.e. 10" x 10"-8")

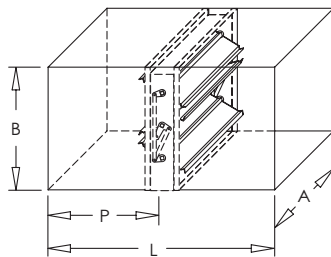

SLEEVE TYPE A

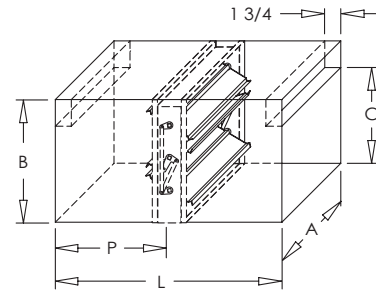

SLEEVE TYPE B

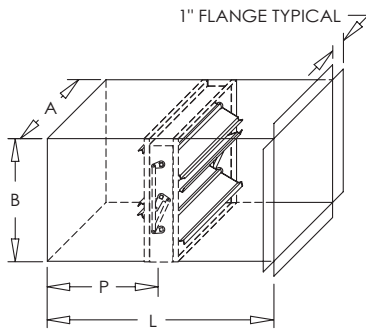

SLEEVE TYPE C

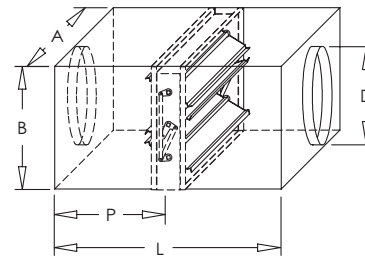

SLEEVE TYPE D

Note: Drawings required for sleeve type C or non-standard sleeves. Specify required dimensions A, B, C, D, L and P prior to ordering.

Motor Sizing and Selection for 3000P and 3000 OBD Series Air Control Dampers

Damper Series	Torque Loading	Load Multiplier		
		Under 2 in. W.C. static or less than 1000 FPM velocity	2-3 in. W.C. static or 1000-2500 FPM Velocity	3-4 in. W.C. static or 2500-3000 FPM velocity
3000 OBD – Opposed Blade, without edge seals, for non-tight close-off applications	3 in-lb/sq. ft.	1	1.5	2
3000P – Parallel blade, without edge seals, for non-tight close-off applications	4 in-lb/sq. ft.	1	1.5	2
3000 OBDLL – Opposed Blade Low Leak, with edge seals, for tight close-off applications	5 in-lb/sq. ft.	1	1.5	2
3000 PLL – Parallel Blade Low Leak, with edge seals, for tight close-off applications	7 in-lb/sq. ft.	1	1.5	2

Motor Sizing Calculations:

$$\left(\frac{\text{Torque Loading}}{\text{Load Multiplier}} \right) \times \text{Damper Area} \text{ sq. ft.} = \text{Required Motor Torque in-lb}$$

Example: Opposed Blade Low Leak damper with tight close-off (3000 OBDLL) and an area of 14 sq. ft. Velocity through the damper is 2200 FPM. Use chart above to find the required Torque Loading and Load Multiplier. Calculate the Required Motor Torque and use chart below to find the appropriate sized motor.

Example calculation shown below:

$$\left(\frac{5 \text{ in-lb/sq. ft.}}{1.5} \right) \times 14 \text{ sq. ft.} = 105 \text{ in-lb}$$

Motor Series	Torque (maximum damper area*)	Spring Return	Power	Control Signal
SAFBUP	180 in-lb (45 sq. ft.)	Yes	24-240V	on/off
SAF24	180 in-lb (45 sq. ft.)	Yes	24V	on/off
SAF24-SR	180 in-lb (45 sq. ft.)	Yes	24V	2-10VDC
SAF24-SR95	180 in-lb (45 sq. ft.)	Yes	24V	0-035ohm
SNF120	90 in-lb (22 sq. ft.)	Yes	24-240V	on/off
SNF24	90 in-lb (22 sq. ft.)	Yes	24V	on/off
SNF24-SR	90 in-lb (22 sq. ft.)	Yes	24V	2-10VDC
SLF120	35 in-lb (8 sq. ft.)	Yes	120V	on/off
SLF24	35 in-lb (8 sq. ft.)	Yes	24V	on/off
SLF24-SR	35 in-lb (8 sq. ft.)	Yes	24V	2-10VDC
SGM24	360 in-lb (90 sq. ft.)	No	24V	on/off, floating
SGM24-SR	360 in-lb (90 sq. ft.)	No	24V	2-10VDC
SAM24	180 in-lb (45 sq. ft.)	No	24V	on/off, floating
SAM24-SR	180 in-lb (45 sq. ft.)	No	24V	2-10VDC
SLM24	45 in-lb (11 sq. ft.)	No	24V	on/off, floating
SLM24-SR	45 in-lb (11 sq. ft.)	No	24V	2-10VDC

* Maximum damper area based on 3000P Series at less than 1000 FPM velocity or under 2 in. W.C. static.



OUTSIDE AIR LOUVERS



4500 Series Stationary 4" Outside Air Louver

Standard Features:

- Extruded aluminum construction
- Standard flange frame
- 4" depth
- Louvers set at 45° on 4" centers
- Storm bend on louvers to minimize water from entering behind louver
- Bird screen (1/2" × 1/2")
- Blades run parallel to first dimension given
- Minimum size 6" × 6"
- Maximum one piece size 96" × 60"
- Driftwood Tan

Options:

- 6" depth flange frame
MODEL: 4500-6
- Flush mount channel frame
MODEL: 4500-CF
- Offset flange frame
MODEL: 4500-OF
- Insect Screen (1/16" × 1/16")
MODEL: 4500-IS
- Removable bird screen
MODEL: 4500-RS
- Galvanneal steel construction
- Marine 12 gauge galvanneal construction with fully welded steel frame and louvers
- Fractional, exact I.D. and O.D. dimensions

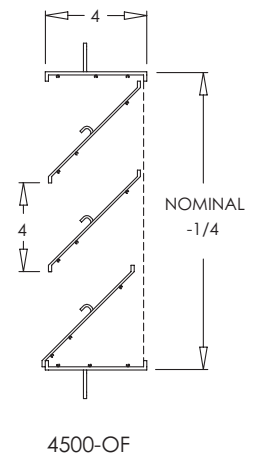
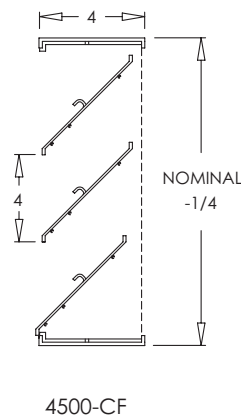
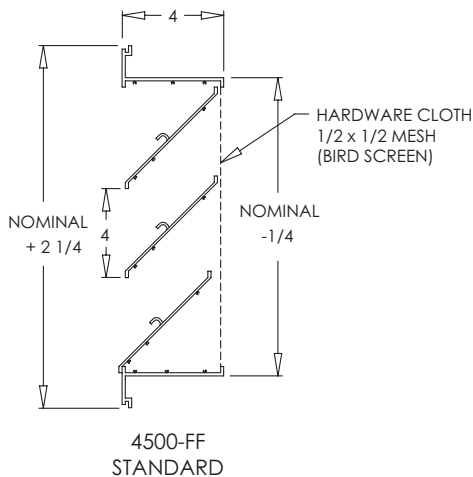

OUTSIDE AIR LOUVERS

4500 Series

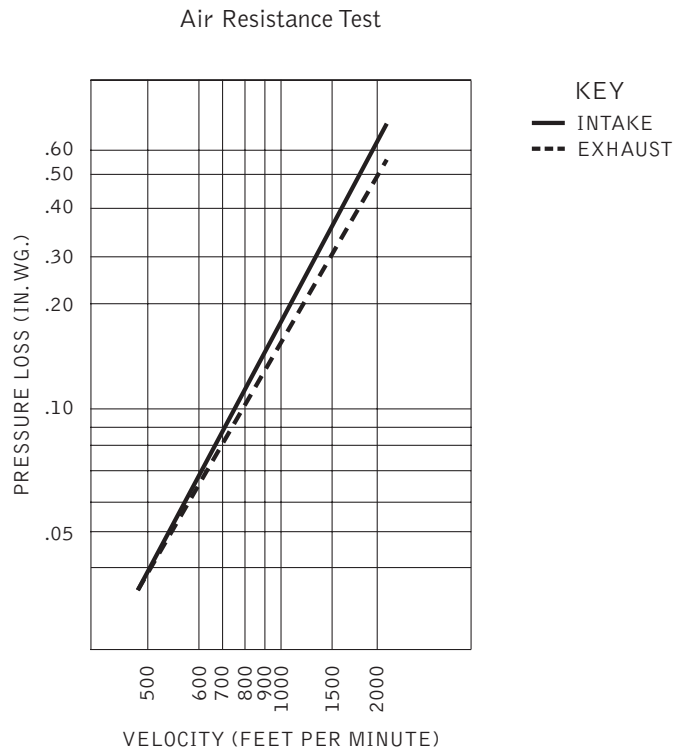
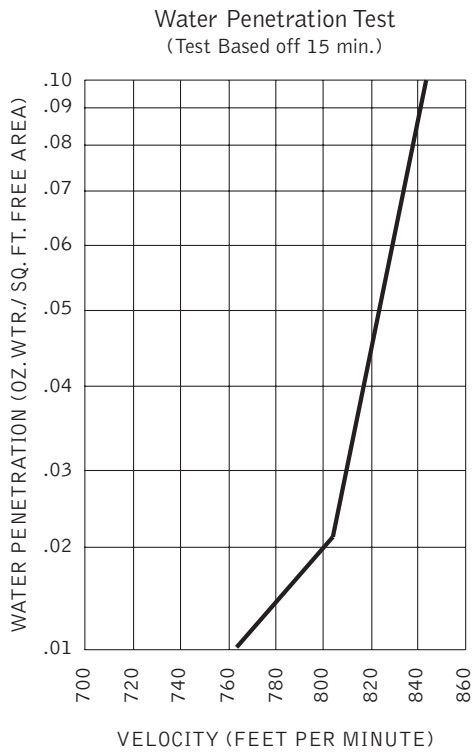

NOTE: Tests based on 48" × 48" size louver.
The beginning point of water penetration is 713 FPM @ 0.01 oz/sq ft of free area.

48" × 48" Example:
8.47 Free Area × 713 FPM = 6,040 CFM

Louver Sizing Calculations:

$$\frac{\text{Air Flow Volume (CFM)}}{\text{Free Area velocity at beginning point of water penetration (FPM)}} = \frac{\text{Required Louver Free Area (ft}^2\text{)}}{\text{Free Area}}$$

4500 Series (Free Area Chart ft²)

Length in Inches	Width in Inches										
	12	18	24	30	36	42	48	54	60	66	72
12	0.26	0.53	0.81	1.08	1.35	1.63	1.90	2.17	2.45	2.72	3.00
18	0.53	0.94	1.35	1.76	2.17	2.58	3.00	3.41	3.82	4.23	4.64
24	0.81	1.35	1.90	2.45	3.00	3.54	4.09	4.64	5.18	5.73	6.28
30	1.08	1.76	2.45	3.13	3.82	4.50	5.18	5.87	6.55	7.24	7.92
36	1.35	2.17	3.00	3.82	4.64	5.46	6.28	7.10	7.92	8.74	9.56
42	1.63	2.58	3.54	4.50	5.46	6.42	7.37	8.33	9.29	10.25	11.20
48	1.90	3.00	4.09	5.18	6.28	7.37	8.47	9.56	10.66	11.75	12.84
54	2.17	3.41	4.64	5.87	7.10	8.33	9.56	10.79	12.02	13.26	14.49
60	2.45	3.82	5.18	6.55	7.92	9.29	10.66	12.02	13.39	14.76	16.13
66	2.72	4.23	5.73	7.24	8.74	10.25	11.75	13.26	14.76	16.26	17.77
72	3.00	4.64	6.28	7.92	9.56	11.20	12.84	14.49	16.13	17.77	19.41

NOTE: CFM values do not have a safety factor built in. It is recommended to oversize the louver to accommodate an additional 20% in Free Area to allow for variations in required airflows. Bird and Insect screens will negatively impact air flow when not properly maintained.

OUTSIDE AIR LOUVERS



4525 Series Storm Resistant Stationary 4" Drainable Outside Air Louver

Standard Features:

- Extruded aluminum construction
- Standard flange frame
- 4" depth
- Louvers set at 45° on 4" centers
- Storm bend on louvers to prevent water from entering
- Water channel in side frame for drainage
- Water slots in bottom frame for drainage
- Bird screen (1/2" × 1/2")
- Blades run parallel to first dimension given
- Minimum size 6" × 6"
- Maximum one piece size 96" × 60"
- Driftwood Tan

Options:

- Flush mount channel frame
MODEL: 4525-CF
- Offset flange frame
MODEL: 4525-OF
- Insect Screen (1/16" × 1/16")
MODEL: 4525-IS
- Removable bird screen
MODEL: 4525-RS
- Fractional, exact I.D. and O.D. dimensions

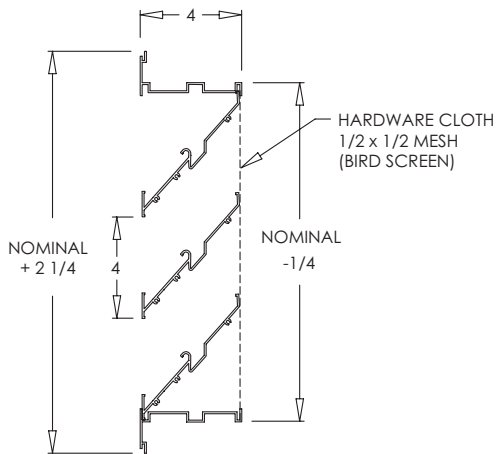

4525-FF
STANDARD

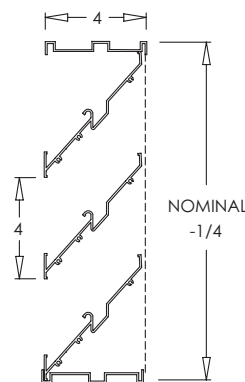

4525-CF

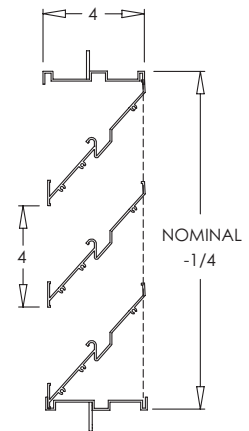

4525-OF

OUTSIDE AIR LOUVERS

4525 Series

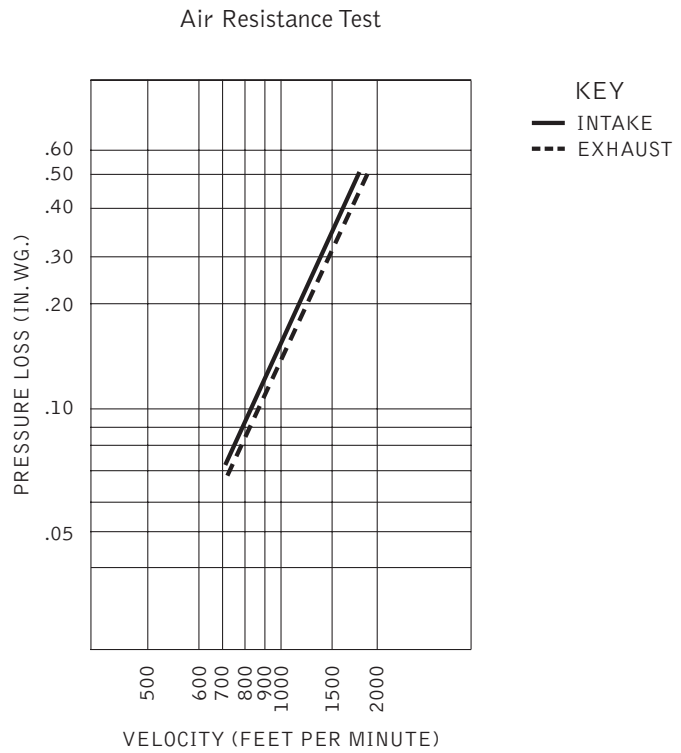
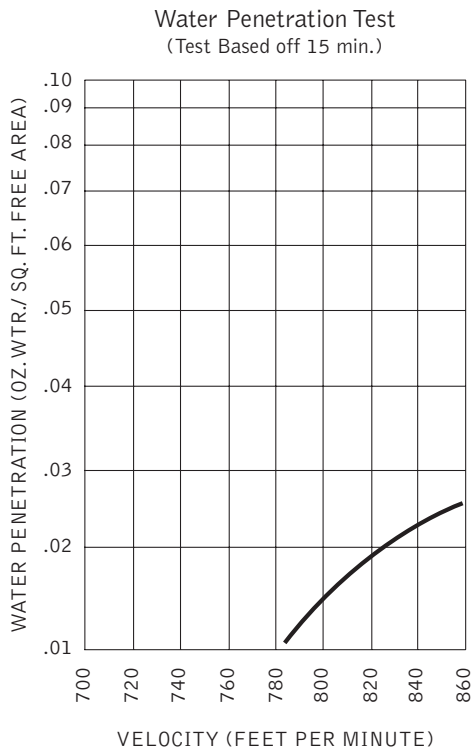

NOTE: Tests based on 48" × 48" size louver.
The beginning point of water penetration is 1059 FPM @ 0.01 oz/sq ft of free area.

48" × 48" Example:
7.93 Free Area × 1059 FPM = 8,398 CFM

Louver Sizing Calculations:

$$\frac{\text{Air Flow Volume (CFM)}}{\text{Free Area velocity at beginning point of water penetration (FPM)}} = \frac{\text{Required Louver Free Area (ft}^2\text{)}}{\text{Free Area}}$$

4525 Series (Free Area Chart ft²)

Length in Inches	Width in Inches										
	12	18	24	30	36	42	48	54	60	66	72
12	0.37	0.63	0.88	1.13	1.38	1.63	1.89	2.14	2.39	2.64	2.89
18	0.63	1.00	1.38	1.76	2.14	2.52	2.89	3.27	3.65	4.03	4.41
24	0.88	1.38	1.89	2.39	2.89	3.40	3.90	4.41	4.91	5.41	5.92
30	1.13	1.76	2.39	3.02	3.65	4.28	4.91	5.54	6.17	6.80	7.43
36	1.38	2.14	2.89	3.65	4.41	5.16	5.92	6.67	7.43	8.19	8.94
42	1.63	2.52	3.40	4.28	5.16	6.04	6.93	7.81	8.69	9.57	10.45
48	1.89	2.89	3.90	4.91	5.92	6.93	7.93	8.94	9.95	10.96	11.97
54	2.14	3.27	4.41	5.54	6.67	7.81	8.94	10.08	11.21	12.34	13.48
60	2.39	3.65	4.91	6.17	7.43	8.69	9.95	11.21	12.47	13.73	14.99
66	2.64	4.03	5.41	6.80	8.19	9.57	10.96	12.34	13.73	15.12	16.50
72	2.89	4.41	5.92	7.43	8.94	10.45	11.97	13.48	14.99	16.50	18.01

NOTE: CFM values do not have a safety factor built in. It is recommended to oversize the louver to accommodate an additional 20% in Free Area to allow for variations in required airflows. Bird and Insect screens will negatively impact air flow when not properly maintained.

OUTSIDE AIR LOUVERS



4550 Series Stationary 2" Outside Air Louver

Standard Features:

- Extruded aluminum construction
- Standard flange frame
- 2" depth
- Louvers set at 45° on 2" centers
- Storm bend on louvers to minimize water from entering behind louver
- Bird screen (1/2" × 1/2")
- Blades run parallel to first dimension given
- Minimum size 6" × 6"
- Maximum one piece size 96" × 60"
- Driftwood Tan

Options:

- Flush mount channel frame
MODEL: 4550-CF
- Offset flange frame
MODEL: 4550-OF
- Insect Screen (1/16" × 1/16")
MODEL: 4550-IS
- Removable bird screen
MODEL: 4550-RS
- Galvanneal steel construction
- Marine 12 gauge galvanneal construction with fully welded steel frame and louvers
- Fractional, exact I.D. and O.D. dimensions

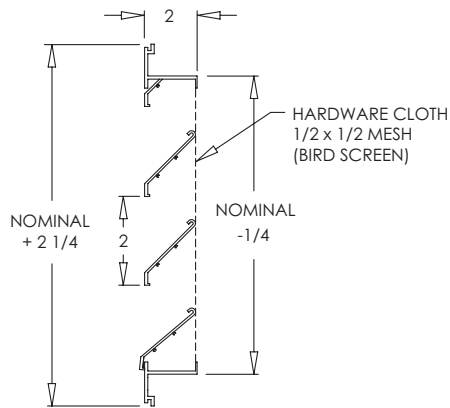

4550-FF
STANDARD

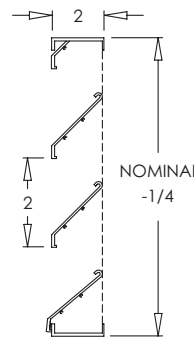

4550-CF

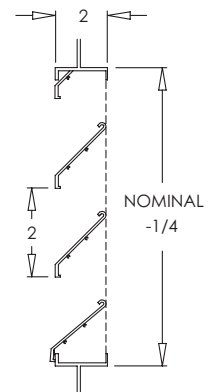

4550-OF

OUTSIDE AIR LOUVERS

4550 Series

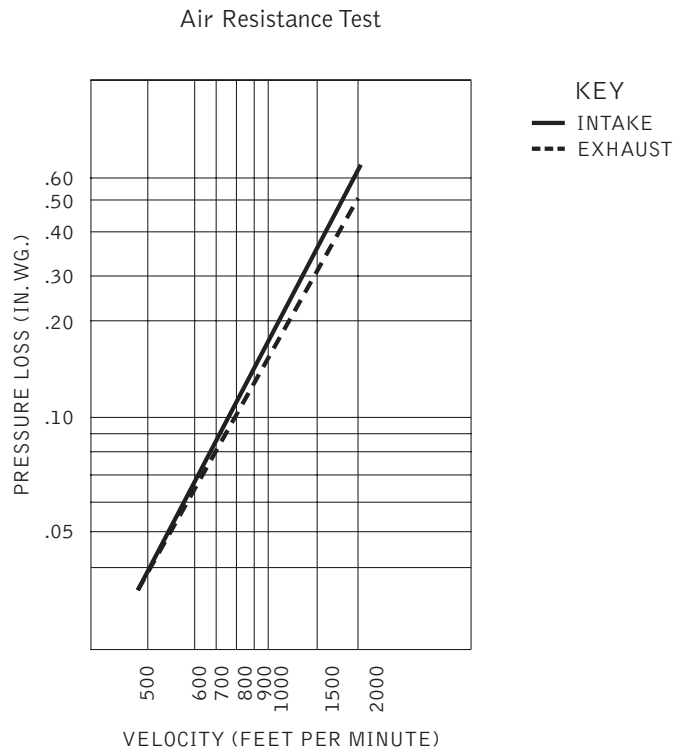
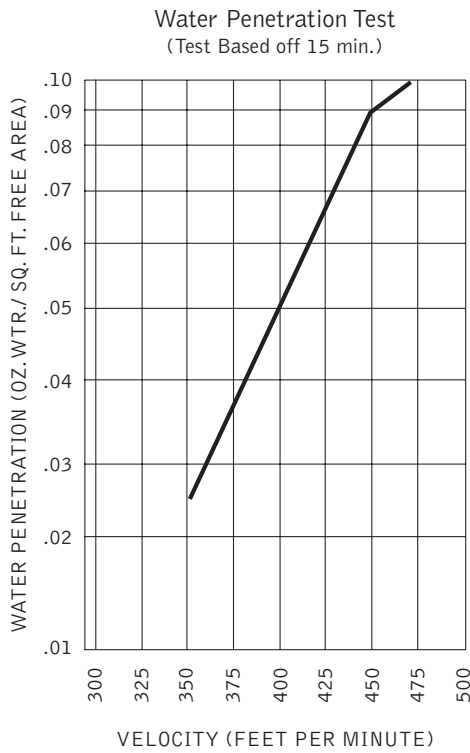

NOTE: Tests based on 48" × 48" size louver.
The beginning point of water penetration is 1059 FPM @ 0.01 oz/sq ft of free area.

48" × 48" Example:
7.93 Free Area × 1059 FPM = 8,398 CFM

Louver Sizing Calculations:

$$\frac{\text{Air Flow Volume (CFM)}}{\text{Free Area velocity at beginning point of water penetration (FPM)}} = \frac{\text{Required Louver Free Area (ft}^2\text{)}}{\text{Free Area}}$$

4550 Series (Free Area Chart ft²)

Length in Inches	Width in Inches										
	12	18	24	30	36	42	48	54	60	66	72
12	0.37	0.63	0.88	1.13	1.38	1.63	1.89	2.14	2.39	2.64	2.89
18	0.63	1.00	1.38	1.76	2.14	2.52	2.89	3.27	3.65	4.03	4.41
24	0.88	1.38	1.89	2.39	2.89	3.40	3.90	4.41	4.91	5.41	5.92
30	1.13	1.76	2.39	3.02	3.65	4.28	4.91	5.54	6.17	6.80	7.43
36	1.38	2.14	2.89	3.65	4.41	5.16	5.92	6.67	7.43	8.19	8.94
42	1.63	2.52	3.40	4.28	5.16	6.04	6.93	7.81	8.69	9.57	10.45
48	1.89	2.89	3.90	4.91	5.92	6.93	7.93	8.94	9.95	10.96	11.97
54	2.14	3.27	4.41	5.54	6.67	7.81	8.94	10.08	11.21	12.34	13.48
60	2.39	3.65	4.91	6.17	7.43	8.69	9.95	11.21	12.47	13.73	14.99
66	2.64	4.03	5.41	6.80	8.19	9.57	10.96	12.34	13.73	15.12	16.50
72	2.89	4.41	5.92	7.43	8.94	10.45	11.97	13.48	14.99	16.50	18.01

NOTE: CFM values do not have a safety factor built in. It is recommended to oversize the louver to accommodate an additional 20% in Free Area to allow for variations in required airflows. Bird and Insect screens will negatively impact air flow when not properly maintained.

OUTSIDE AIR LOUVERS



4600 Series Adjustable 4" Outside Air Louver

Standard Features:

- Extruded aluminum construction
- Standard flange frame
- 4" depth
- Adjustable louvers on 4" centers
- Spring loaded close
- Storm bend on louvers to prevent water from entering
- Bird screen (1/2" × 1/2")
- Blades run parallel to first dimension given
- 1/4" pivot pins in nylon bushings
- Minimum size 12" × 12"
- Maximum one piece size 48" × 48"
- Brown Finish

Options:

- Flush mount channel frame
MODEL: 4600-CF
- Offset flange frame
MODEL: 4600-OF
- Insect Screen (1/16" × 1/16")
MODEL: 4600-IS
- Fractional, exact I.D. and O.D. dimensions

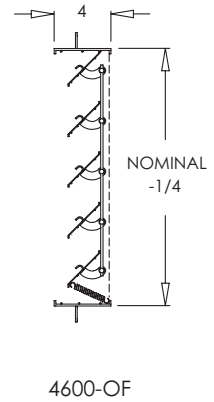
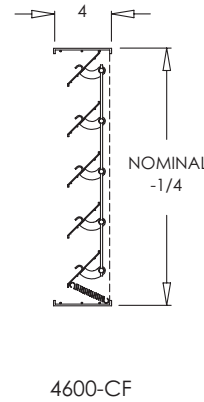
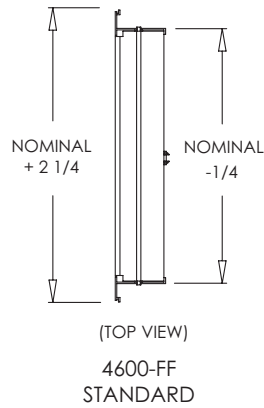
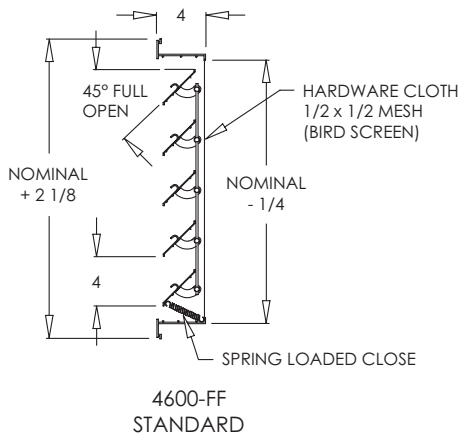

OUTSIDE AIR LOUVERS



4700 Series Stationary 4" Outside Air Louver Radius and Special Shapes

Standard Features:

- Extruded aluminum construction
- Standard flange frame
- 4" depth
- Louvers set at 45° on 4" centers
- Storm bend on louvers to minimize water from entering behind louver
- Bird screen (1/2" × 1/2")
- Blades run parallel to first dimension given
- Driftwood Tan

Options:

- Stationary 2" outside air louver radius and special shapes
MODEL: 4750
- Flush mount channel frame
MODEL: 4700-CF
- Offset flange frame
MODEL: 4700-OF
- Insect Screen (1/16" × 1/16")
MODEL: 4700-IS
- Fractional dimensions



Style

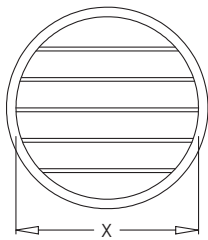

STYLE 1

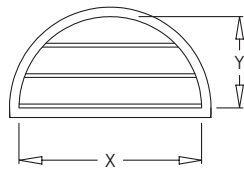

STYLE 2

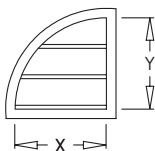

STYLE 3

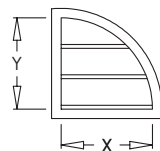

STYLE 4

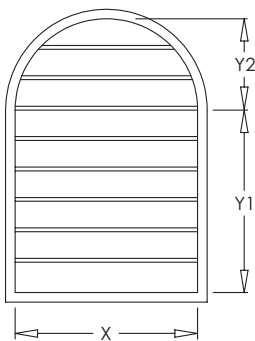

STYLE 5

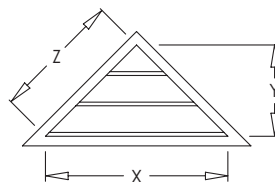

STYLE 6

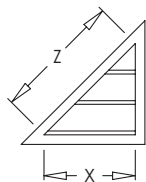

STYLE 7



STYLE 8

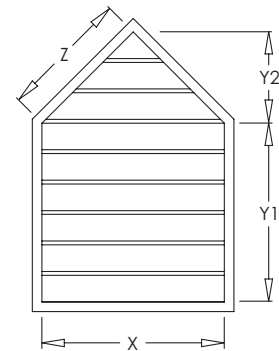

STYLE 9

Frames

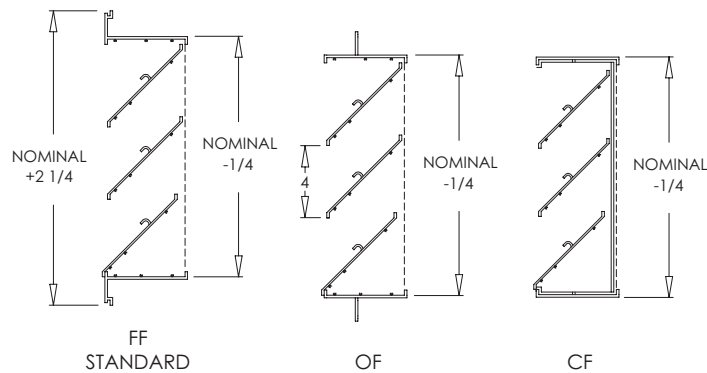

Note: Must specify style of louver & required X, Y, and Z dimensions when ordering.

OUTSIDE AIR LOUVERS



4800 Series Extruded Aluminum Brick Vent

Standard Features:

- Storm resistant brick vent
- Extruded aluminum construction
- Standard channel frame
- 4" depth
- Louvers set at 45° on 1" centers
- 1/8" thick extruded aluminum blades fastened with corrosion resistant bolts
- Insect screen
- Blades run parallel to first dimension given
- Minimum size is 4" × 2-1/4" (W × H)
- Mill Finish

Options:

- Extruded aluminum brick vent with 1" flange frame and 1 – 1/4" depth

MODEL: 4850

- Fractional, exact I.D. and O.D. dimensions

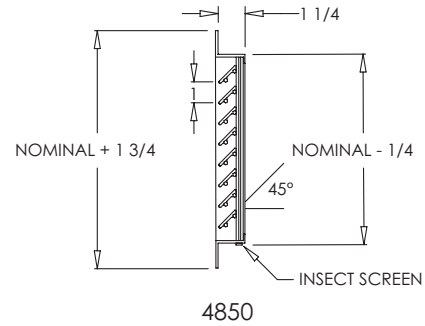
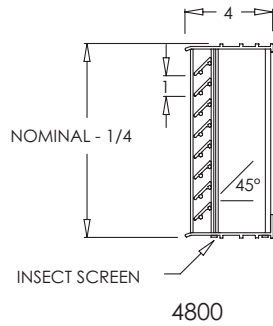

ROUND OUTSIDE AIR LOUVERS



4901 Series Round Aluminum Vent Louver

Standard Features:

- Lightweight aluminum vent louver
- Able to withstand wet and corrosive environments
- Mounting springs secure vent in duct
- Easily installed using only high grade silicon caulk (provided by others)
- Designed for duct sizes 3"-8"
- Anodized Finish

Options:

- Round aluminum vent louver designed for duct sizes 10"-16"
MODEL: 4902
- Insect Screen
MODEL: 4901-IS

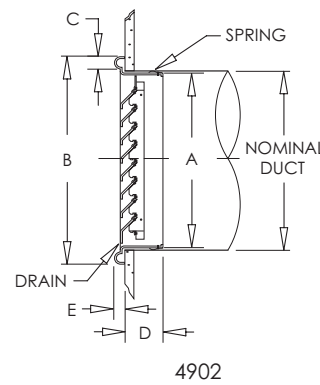
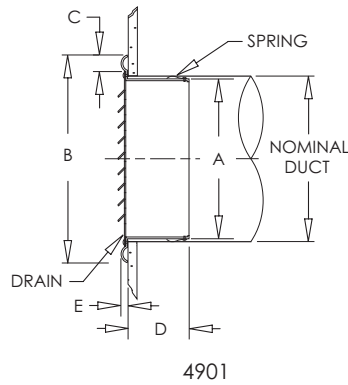

4901 Dimensions

Duct Size	Free Area	A	B	C	D	E
3"	.02 ft ²	2 29/32"	4 13/16"	19/32"	1 3/8"	9/32"
4"	.04 ft ²	3 13/16"	5 23/32"	19/32"	1 21/32"	9/32"
5"	.05 ft ²	4 3/4"	6 21/32"	19/32"	1 25/32"	9/32"
6"	.08 ft ²	5 23/32"	8	25/32"	2 3/4"	9/32"
7"	.11 ft ²	6 11/16"	8 31/32"	25/32"	2 3/4"	9/32"
8"	.14 ft ²	7 11/16"	10"	25/32"	2 3/4"	9/32"

4902 Dimensions

Duct Size	Free Area	A	B	C	D	E
10"	.19 ft ²	9 21/32"	12 11/16"	1"	2 31/32"	13/32"
12"	.27 ft ²	11 19/32"	14 21/32"	1"	2 31/32"	13/32"
14"	.37 ft ²	13 19/32"	16 5/8"	1"	3 11/32"	19/32"
16"	.49 ft ²	15 9/16"	18 19/32"	1"	3 11/32"	19/32"

DAMPER LOUVER COMBINATIONS

Shoemaker dampers and louvers can be combined with a 20 gauge steel sleeve to create an environment to regulate airflow in or out of a louver with an operable blade damper.

Dampers available in combinations including the 3510—Pressure Relief Damper, 3550—Backdraft Damper, 3000P—Parallel Blade Damper or 3000BD—Opposed Blade Damper (low leak packages available on parallel blade and opposed blade models.) Damper frame and blade material varies by series – see damper product page for details.

Louvers available in combinations including the 4500—Stationary Outside Air Louver (4" depth,) 4550—Stationary Outside Air Louver (2" depth) and 4525—Drainable Outside Air Louver (4" depth). All louvers are extruded aluminum construction and come standard with 1/2" x 1/2" bird screen.

How to Order:

1	Select Outside Air Louver (Required)
2	Select Louver Frame Mount (Required)
3	Select Louver Options (Optional)
4	Select Louver Finish (Required)
5	Select Damper (Required)
6	Select Damper Options (Optional)
7	Combination Size (Required)

1 Select Outside Air Louver (Required)

- a. Stationary Outside Air Louver 4"
 - MODEL: 4500 (See page 152 for more details)
- b. Storm Resistant Stationary 4" Drainable Outside Air Louver
 - MODEL: 4525 (See page 154 for more details)
- c. Stationary Outside Air Louver 2"
 - MODEL: 4550 (See page 156 for more details)

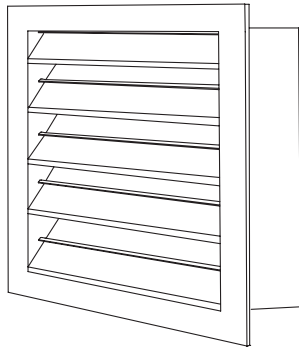

4500

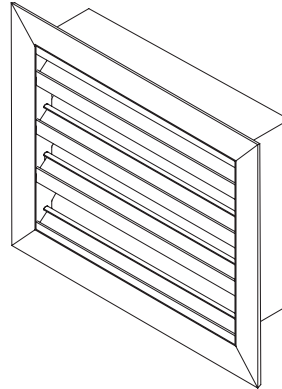

4525

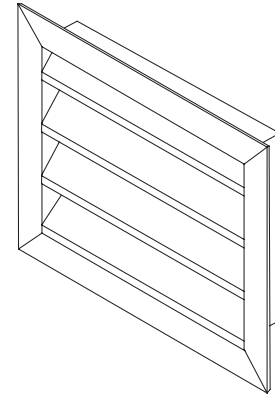

4550

2 Select Louver Frame Mount (Required)

- a. FF – Flange Frame
- b. OF – Offset Flange Frame (must indicate offset from face of louver)
- c. CF – Channel Frame

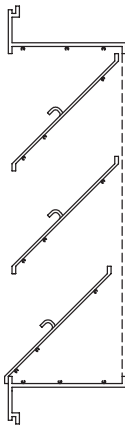

FF

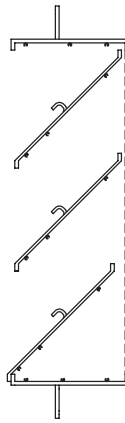

OF

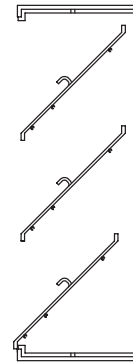

CF

3 Select Louver Options

- a. IS – Insect Screen (louvers come standard with 1/2" × 1/2" Bird Screen)

4 Select Louver Finish (Required)

- a. Standard colors 
- b. Mill Finish 
- c. Designer Color 
- d. Aluminum Paint 

NOTE: Finishes for louver only (all dampers and sleeves are standard Mill Finish)

5

Select Damper (Required)

- a. Pressure Relief
 - i. Pressure Relief Damper
MODEL: 3510 (See page 148 for more details)
 1. Select Intake or Exhaust
- b. Pressure Differential Backdraft Damper
 - i. Pressure Differential Backdraft Damper with adjustable counter balance
MODEL: 3550 (See page 149 for more details)
 1. Select Intake or Exhaust
- c. Air Control Damper
 - i. Parallel Blade
MODEL: 3000P (See page 144 for more details)
 - ii. Opposed Blade
MODEL: 3000 OBD (See page 145 for more details)

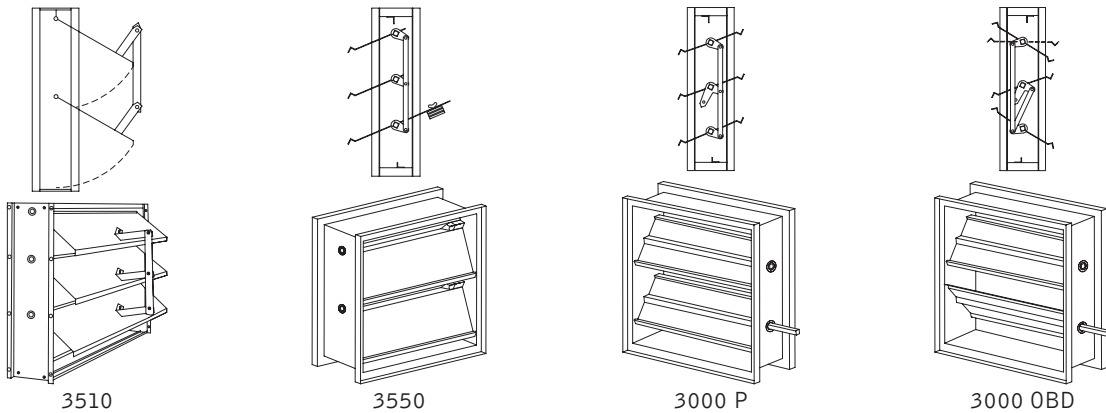

6

Select Damper Options

- a. Low Leak Package (available on Air Control Dampers only)
- b. Adjustable counter balance (available only on select sizes of 3510—Pressure Relief Damper)
- c. Direct Motor Mount (motors sold separately see page 151 for more details, available on Air Control Dampers only)

7

Combination Size (Required)

- a. Specify Size (blade length determined by first dimension given)
 - Fractional, exact O.D. dimensions available
 - Minimum one piece size 6"×6"
 - Maximum one piece size 48"×48" (combinations with 3510 damper, maximum one piece size is 24"×24")

Combination Dimensions

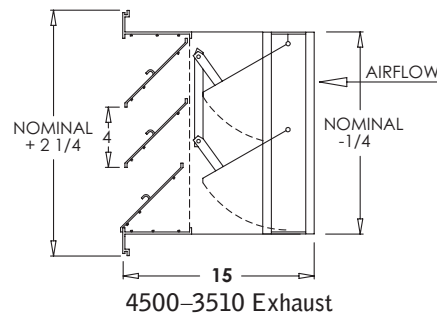
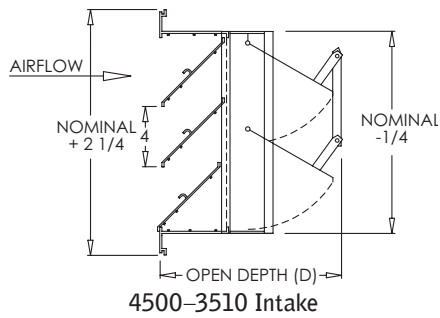

4500-3510 & 4525-3510 Intake Dimension Chart

Height	Open Depth (D)	Height	Open Depth (D)	Height	Open Depth (D)
6"	9 3/4"	12"	11 3/8"	18"	12 1/8"
8"	11 3/4"	14"	12 1/4"	20"	11 1/4"
10"	13 3/4"	16"	11"	24"	11 5/8"

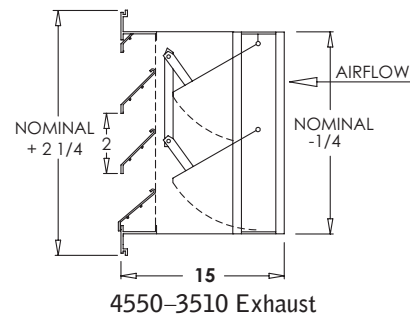
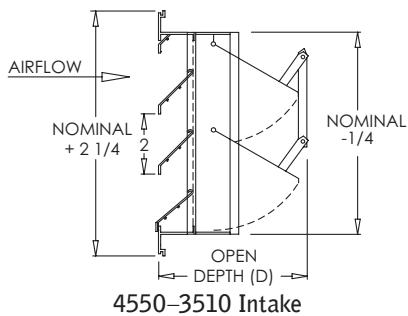

4550-3510 Intake Dimension Chart

Height	Open Depth (D)	Height	Open Depth (D)	Height	Open Depth (D)
6"	7 3/4"	12"	9 3/8"	18"	10 1/8"
8"	9 3/4"	14"	10 1/4"	20"	9 1/4"
10"	11 3/4"	16"	9"	24"	9 5/8"

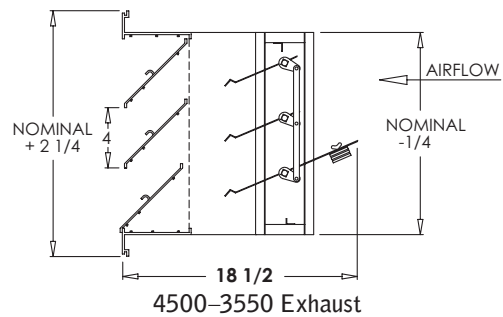
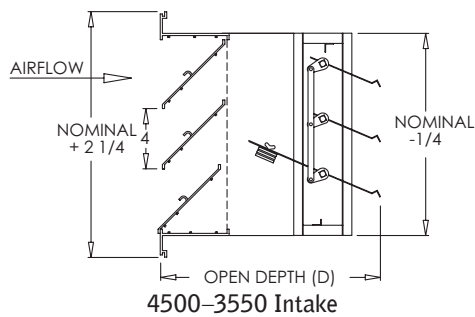

4500-3550 & 4525-3550 Intake Dimension Chart

Height	Open Depth (D)	Height	Open Depth (D)	Height	Open Depth (D)
6"	11 5/8"	18"	14 3/8"	34"	13 3/8"
8"	13 5/8"	20"	12 7/8"	36"	14 3/8"
8" DB.	11 5/8"	22"	13 3/8"	38"	12 7/8"
10"	15 5/8"	24"	14 3/8"	40"	13 3/8"
10" DB.	11 5/8"	26"	12 7/8"	42"	14 3/8"
12"	11 5/8"	28"	13 3/8"	44"	12 7/8"
14"	12 3/8"	30"	14 3/8"	46"	13 3/8"
16"	13 3/8"	32"	12 7/8"	48"	14 3/8"

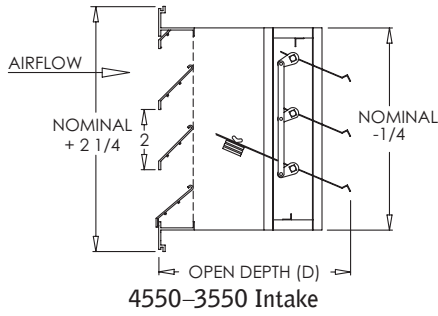

4550-3550 Intake

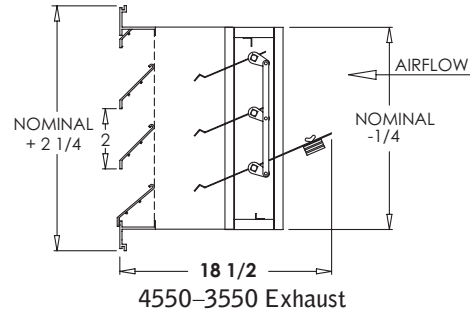

4550-3550 Exhaust

4550-3550 Intake Dimension Chart

Height	Open Depth (D)	Height	Open Depth (D)	Height	Open Depth (D)
6"	9 5/8"	18"	12 3/8"	34"	11 3/8"
8"	11 5/8"	20"	10 7/8"	36"	12 3/8"
8" DB.	9 5/8"	22"	11 3/8"	38"	10 7/8"
10"	13 5/8"	24"	12 3/8"	40"	11 3/8"
10" DB.	9 5/8"	26"	10 7/8"	42"	12 3/8"
12"	9 5/8"	28"	11 3/8"	44"	10 7/8"
14"	10 3/8"	30"	12 3/8"	46"	11 3/8"
16"	11 3/8"	32"	10 7/8"	48"	12 3/8"

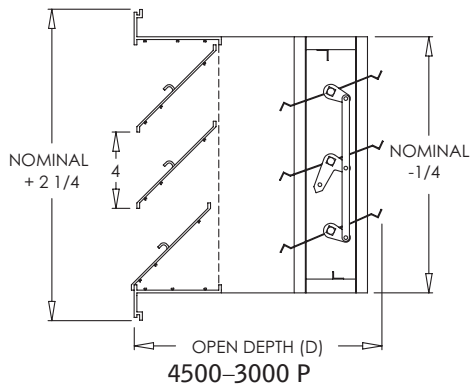

4500-3000 P

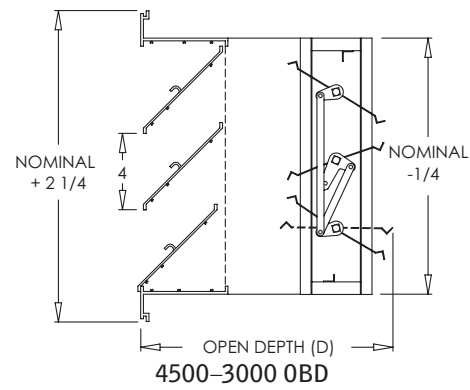

4500-3000 OBD

4500-3000 OBD, 4525-3000 OBD & 4550-3000 OBD Dimension Chart

Height	Open Depth (D)	Height	Open Depth (D)	Height	Open Depth (D)
8"	15"	22"	16 1/4"	36"	17 1/4"
10"	15 1/2"	24"	17 1/4"	38"	15 3/4"
12"	15 3/4"	26"	15 3/4"	40"	16 1/4"
14"	15 3/4"	28"	16 1/4"	42"	17 1/4"
16"	16 1/4"	30"	17 1/4"	44"	15 3/4"
18"	17 1/4"	32"	15 3/4"	46"	16 1/4"
20"	15 3/4"	34"	16 1/4"	48"	17 1/4"

Note: Add 3/4" to Open Depth (D) for Low Leak Package

4500-3000P, 4525-3000P & 4550-3000P Dimension Chart

Height	Open Depth (D)	Height	Open Depth (D)	Height	Open Depth (D)
6"	15"	18"	17 1/4"	34"	16 1/4"
8"	16 1/8"	20"	15 3/4"	36"	17 1/4"
8" DB.	15"	22"	16 1/4"	38"	15 3/4"
10"	17 1/8"	24"	17 1/4"	40"	16 1/4"
10" DB.	15 1/2"	26"	15 3/4"	42"	17 1/4"
12"	15 3/4"	28"	16 1/4"	44"	15 3/4"
14"	15 3/4"	30"	17 1/4"	46"	16 1/4"
16"	16 1/4"	32"	15 3/4"	48"	17 1/4"

Note: Add 3/4" to Open Depth (D) for Low Leak Package

ACCESS DOORS

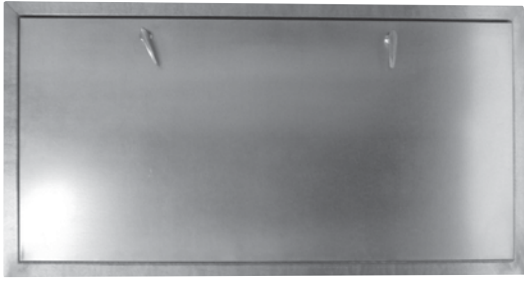

6000 Series Insulated Access Door

Standard Features:

- Hinged style access door
- Galvanized steel
- Neoprene gasketing to ensure tight seal between door and frame
- Insulated door
- Designation label on door
- Mill Finish

Options:

- Cam style insulated access door
MODEL: 6500
- Hinged insulated access door for fiberglass duct
MODEL: 6001
- Cam style insulated access door for fiberglass duct
MODEL: 6501

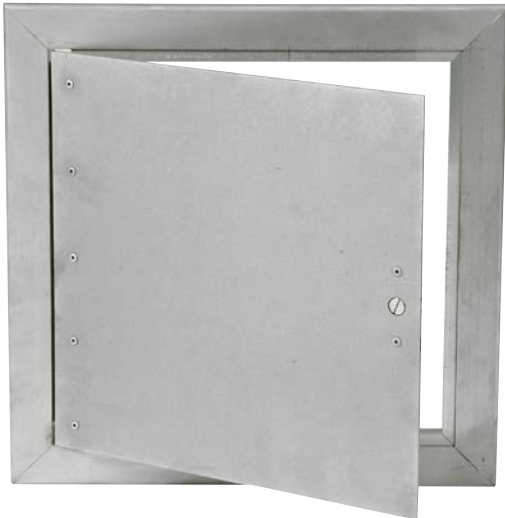

6700 Series Insulated Access Door

Standard Features:

- 16 gauge galvanized steel construction
- One piece constructed 1" wide flange frame for concealment of rough wall opening
- 1/4" mounting slots for fastening within furred spaces allows faster installation and maximum clearance
- Concealed pivoting rod hinge, doors 24" and larger are constructed with a continuous piano hinge
- Screwdriver operated latch
- Prime Coat Finish

Options:

- Type 304 stainless steel construction
MODEL: 6700-SS



AD Series Access Door

Standard Features:

- Access door with 1 3/8" deep steel roll formed frame
- Hinged removable door with hinges parallel to longest dimension
- Hand operated lever for easy access
- 4-way reversible door on square sizes
- 2-way reversible door on rectangular sizes
- Concealed mounting holes
- Soft white powder finish

Options:

- Filter Grille Access Door
MODEL: FG/AD





6600 Series Insulated Access Door

Standard Features:

- Provides easy access into air ducts and units, no tools required to open and close
- Three layers of precision stamped steel provide a solid, well-insulated, leak-proof door
- High density fiberglass insulation
- Simple installation
- Red polypropylene molded knobs with threaded metal inserts
- Zinc plated bolts are clinched and sealed to the inner door
- Self-adhesive template provided for exact size of duct opening required
- Mill Finish

Options:

- Observation door only, 4" × 2 5/8" window
MODEL: 6600-OD
- High-temp access door, designed for high temperature applications up to 1000° F
MODEL: 6600-HT1
- High-temp grease duct access door, designed for grease duct applications up to 2300° F
MODEL: 6600-HT2



OVERVIEW

Shoemaker offers a comprehensive line of UL and California State Fire Marshall listed products for fire and smoke control in commercial and industrial HVAC systems. The product line includes T-Bars, curtain-type fire dampers, ceiling radiation dampers, access doors and combination fire-smoke dampers.

Product Key

The product key located on the bottom of each page uses symbols to note options, features and services that are found repeatedly throughout this section of the catalog:



EXPEDITED SERVICES PROGRAM – CONTACT FACTORY

Contact factory for Expedited Service Program availability, products manufactured faster than standard lead times. Additional charges apply. See website for program details.



EXTENDED LEADTIME

Product not available in our standard lead time. Contact customer service for lead time quote.

2 IN. CURTAIN TYPE



2502 Series Thin-line 1 1/2 Hour Rated Fire Damper

Standard Features:

- Square or rectangular spring actuated curtain-type fire damper for vertical or horizontal mount
- 2" thin-line roll formed frame
- Designed for use in walls, floors and partitions with fire resistance ratings of 1 1/2 hours or less (for ceiling application, see pages 184–188)
- UL listed and tested in accordance with UL Standard 555
- 1 1/2 hour fire resistance rating
- Building materials rated 2 Hours or less
- CSFM California State Fire Marshal listed
- Interlocking steel roll-formed blades
- Blade lock to secure blades once product is activated
- Damper manufactured from corrosion tested galvanized mild steel (G-90)
- 165° replaceable fusible link
- Maximum one piece size 41" W, 36" H

Options:

- Vertical mount only, maximum one piece size 48" W, 49" H
- **MODEL: 2501**
- Stainless steel
- Sleeves – see page 183
- Fractional, exact O.D. dimensions

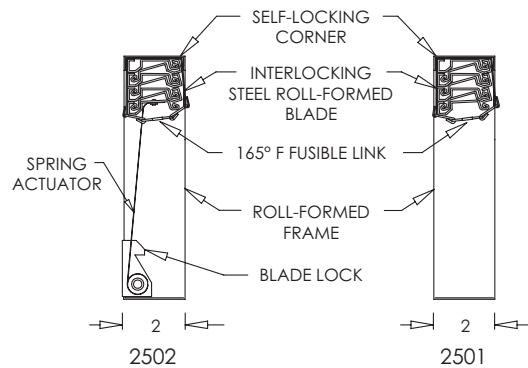
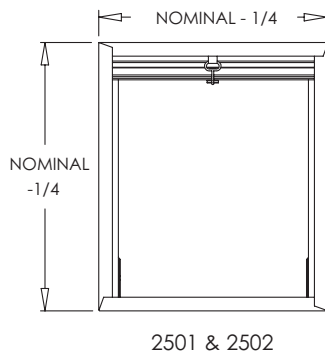
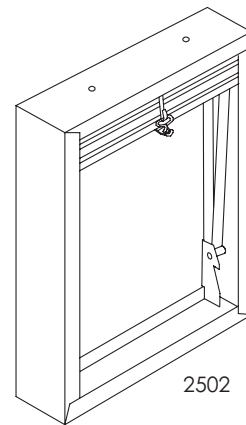
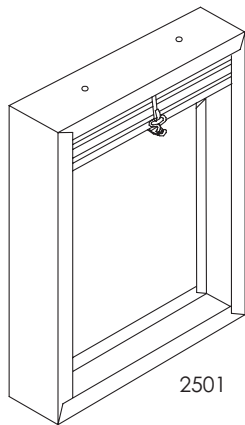

2 IN. CURTAIN TYPE



2534 Series Thin-line Out-of-Airstream 1 1/2 Hour Fire Damper

Standard Features:

- Square or rectangular spring actuated curtain-type fire damper for vertical or horizontal mount
- 2" thin-line roll formed out-of-airstream frame
- Designed for use in walls, floors and partitions with fire resistance ratings of 2 hours or less (for ceiling application, see pages 184–188)
- UL listed and tested in accordance with UL Standard 555
- 1 1/2 hour fire resistance rating
- Building materials rated 2 Hours or less
- CSFM California State Fire Marshal listed
- Interlocking steel roll-formed blade
- Blade lock
- Damper manufactured from corrosion tested galvanized mild steel (G-90)
- 165° replaceable fusible link
- Maximum one piece size 41" W, 29" H

Options:

- Vertical mount only, maximum one piece size 48" W, 41" H

MODEL: 2533

- Stainless steel
- Sleeves – see page 183
- Fractional, exact O.D. dimensions



2533 & 2534 Frame Height	
Duct Size	Height (B)
4" - 7"	+1 3/4"
8" - 12"	+2 3/4"
13" - 17"	+3 3/4"
18" - 24"	+4 3/4"
25" - 28"	+5 3/4"
29" - 34"	+6 3/4"
35" - 41"	+7 3/4"
Note: Duct sizes 30"–41" available in 2533 only.	
Example: Height (B) for 20" duct would be 24 3/4"	

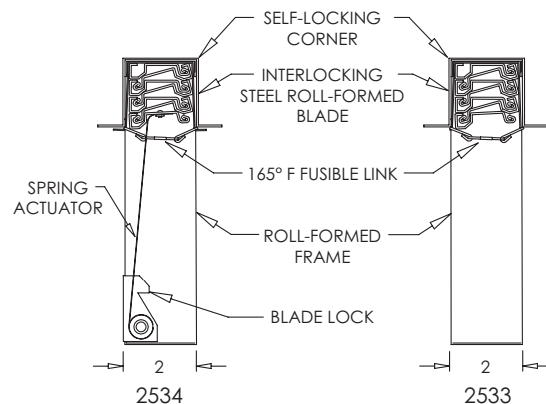
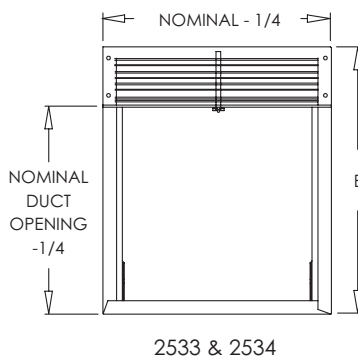
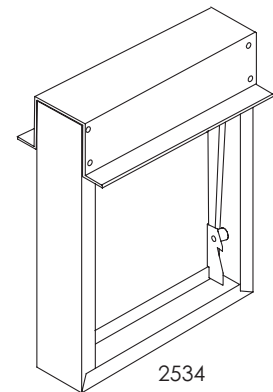
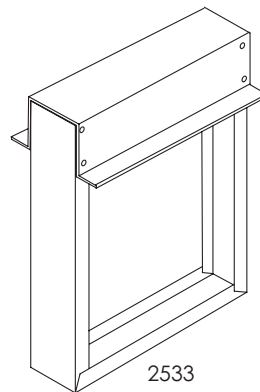

2 IN. CURTAIN TYPE



2550 Series Round Thin-line Out-of-Airstream 1 1/2 Hour Rated Fire Damper

Standard Features:

- Spring actuated curtain-type fire damper with 2 1/4" round connection for horizontal or vertical mount
- 2" thin-line roll formed out-of-airstream frame
- Designed for use in walls, floors and partitions with fire resistance ratings of 2 hours or less (for ceiling application, see pages 184–188)
- UL listed and tested in accordance with UL Standard 555
- 1 1/2 hour fire resistance rating
- Building materials rated 2 Hours or less
- CSFM California State Fire Marshal listed
- Interlocking steel roll-formed blades
- Blade lock to secure blades once product is activated
- Damper manufactured from corrosion tested galvanized mild steel (G-90)
- 165° replaceable fusible link
- Available in 4" through 29" round

Options:

- Vertical mount only, available 4" through 40" round

MODEL: 2549

- Stainless steel
- Sleeves – see page 183



2549 & 2550 Dimensions	
Duct Size	Height (C)
4" - 7"	+2 3/4"
8" - 12"	+3 3/4"
13" - 17"	+4 3/4"
18" - 24"	+5 3/4"
25" - 28"	+6 3/4"
29" - 34"	+7 3/4"
35" - 40"	+8 3/4"
Note: Duct sizes 30"-41" available in 2549 only.	
Example: Height (C) for 20" duct would be 25 3/4"	

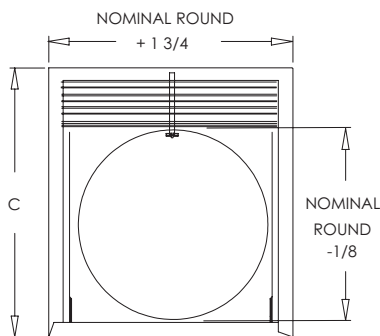
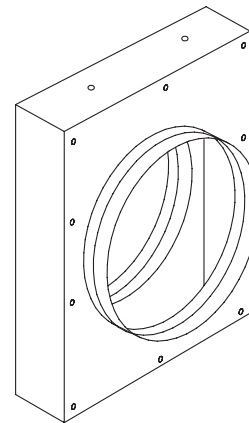

2549 & 2550

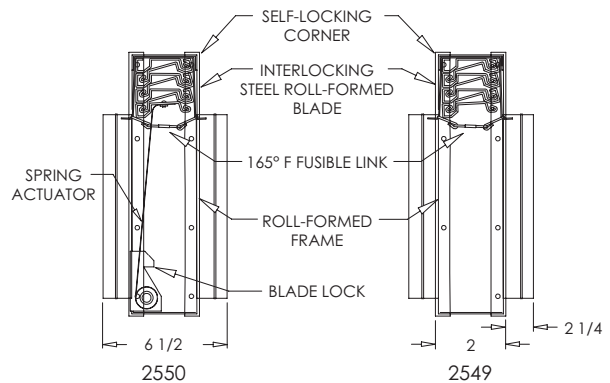

2 IN. CURTAIN TYPE

2561 Series Thin-line 3 Hour Rated Fire Damper

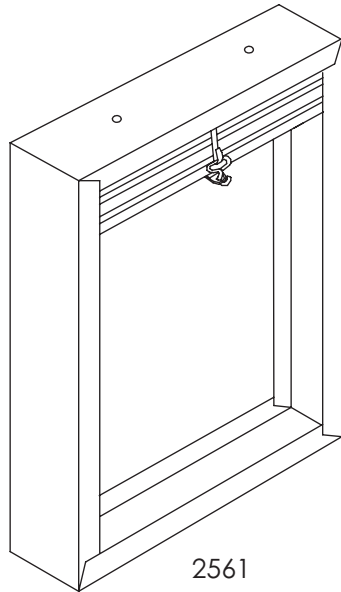

2561

Standard Features:

- Square or rectangular curtain-type fire damper for vertical mount
- 2" thin-line roll formed frame
- Designed for use in walls, floors and partitions with fire resistance ratings of 3 hours or less (for ceiling application, see pages 184–188)
- UL listed and tested in accordance with UL Standard 555
- 3 hour fire resistance rating
- Building materials rated 4 Hours or less
- CSFM California State Fire Marshal listed
- Interlocking steel roll-formed blades
- Damper manufactured from corrosion tested galvanized mild steel (G-90)
- 165° replaceable fusible link
- Maximum size 48" W, 49" H

Options:

- Out-of-Airstream – Maximum size 48" W, 41" H
MODEL: 2563
- Round Out-of-Airstream – Available in 4" through 28" round
MODEL: 2565
- Stainless steel
- Sleeves – see page 183
- Fractional, exact O.D. dimensions

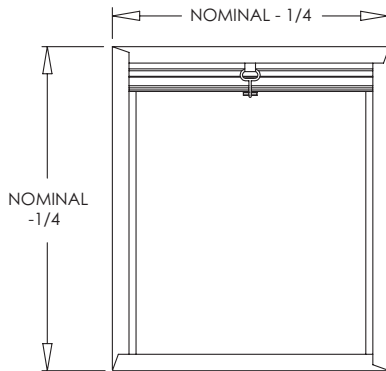

2561

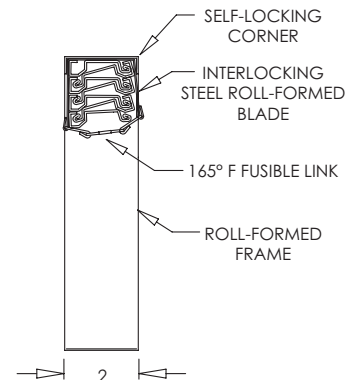

2561

2563 Frame Height	
Duct Size	Height (B)
4" - 7"	+1 3/4"
8" - 12"	+2 3/4"
13" - 17"	+3 3/4"
18" - 24"	+4 3/4"
25" - 28"	+5 3/4"
29" - 34"	+6 3/4"
35" - 40"	+7 3/4"
Example: Height (B) for 20" duct would be 24 3/4"	

2565 Frame Height	
Duct Size	Height (C)
4" - 7"	+2 3/4"
8" - 12"	+3 3/4"
13" - 17"	+4 3/4"
18" - 24"	+5 3/4"
25" - 28"	+6 3/4"
Example: Height (C) for 20" duct would be 25 3/4"	

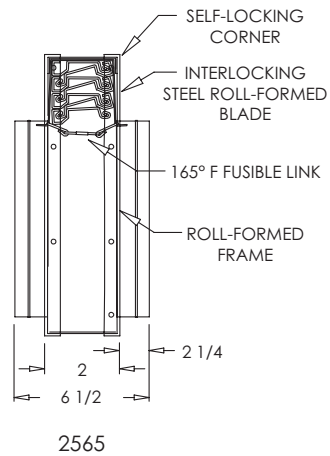
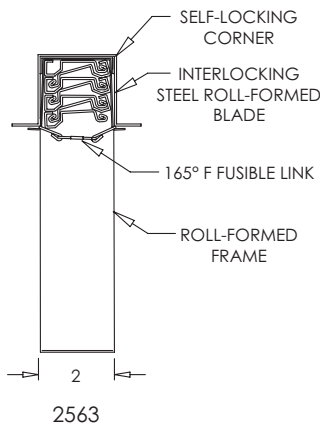
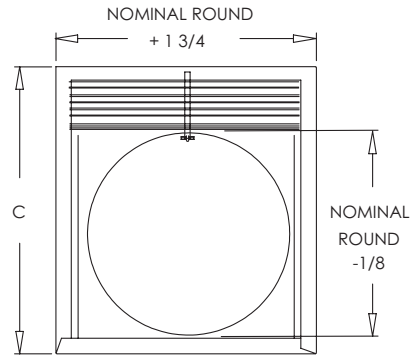
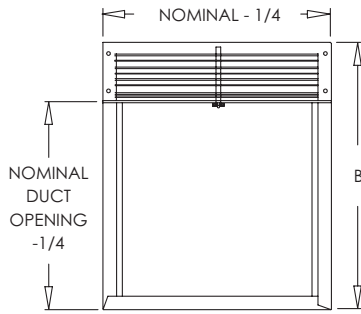
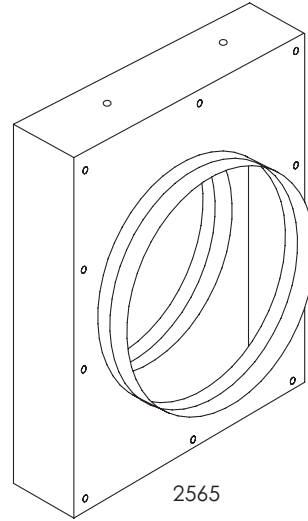
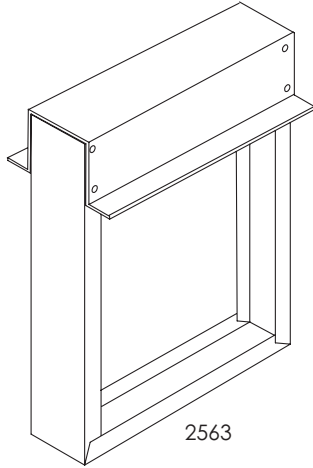

4 IN. CURTAIN TYPE



2602 Series 1 1/2 Hour Rated Fire Damper

Standard Features:

- Square or rectangular spring actuated curtain-type fire damper for horizontal or vertical mount
- 4 1/4" standard roll formed frame
- Designed for use in walls, floors and partitions with fire resistance ratings of 2 hours or less (for ceiling application, see pages 184–188)
- UL listed and tested in accordance with UL Standard 555
- 1 1/2 hour fire resistance rating
- Building materials rated 2 Hours or less
- CSFM California State Fire Marshal listed
- Interlocking steel roll-formed blades
- Blade lock to secure blades once product is activated
- Damper manufactured from corrosion tested galvanized mild steel (G-90)
- 165° replaceable fusible link
- Maximum size 60"×60"

Options:

- Vertical mount only without spring actuator and blade lock, maximum size single section 60"×60" or multiple sections 120"×120"

MODEL: 2601

- Stainless steel
- Sleeves – see page 183
- Fractional, exact O.D. dimensions

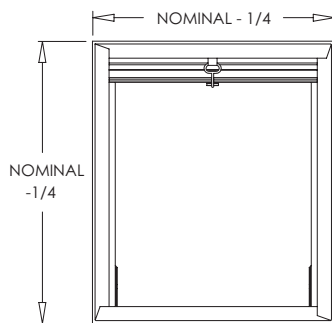
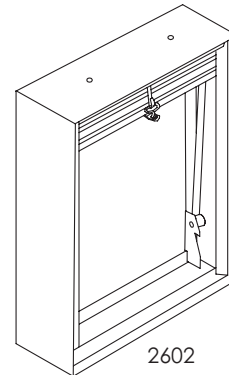
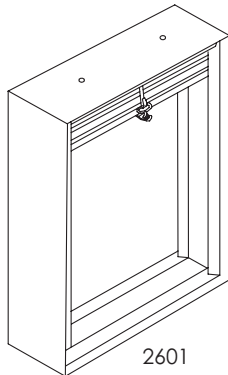

2601 & 2602

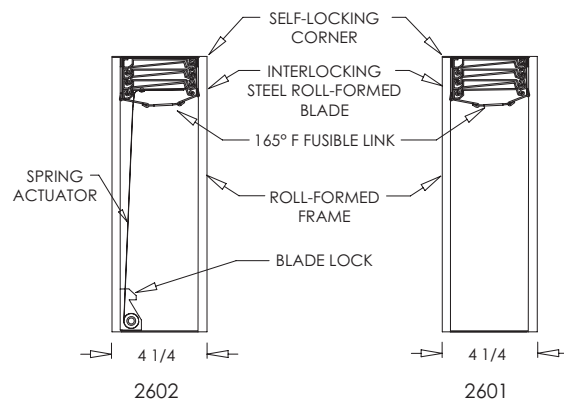

4 IN. CURTAIN TYPE



2634 Series Out-of-Airstream 1 1/2 Hour Rated Fire Damper

Standard Features:

- Square or rectangular spring actuated curtain-type fire damper for horizontal or vertical mount
- 4 1/4" standard roll formed out-of-airstream frame
- Designed for use in walls, floors and partitions with fire resistance ratings of 2 hours or less (for ceiling application, see pages 184–188)
- UL listed and tested in accordance with UL Standard 555
- 1 1/2 hour fire resistance rating
- Building materials rated 2 Hours or less
- CSFM California State Fire Marshal listed
- Interlocking steel roll-formed blade
- Blade lock to secure blades once product is activated
- Damper manufactured from corrosion tested galvanized mild steel (G-90)
- 165° replaceable fusible link
- Maximum dimensions 60" W, 52" H

Options:

- Vertical mount only without spring actuator and blade lock

MODEL: 2633

- Stainless steel
- Sleeves – see page 183
- Fractional, exact O.D. dimensions



2633 & 2634 Frame Height	
Duct Size	Height (B)
4" - 7"	+ 3/4"
8" - 16"	+ 1 3/4"
17" - 26"	+ 2 3/4"
27" - 35"	+ 3 3/4"
36" - 44"	+ 4 3/4"
45" - 52"	+ 5 3/4"

Example: Height (B) for 20" duct would be 22 3/4"

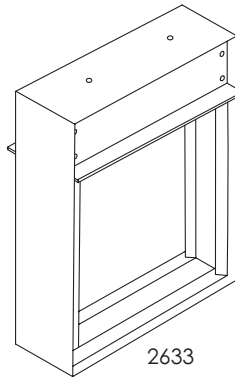

2633

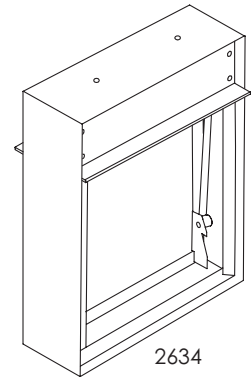

2634

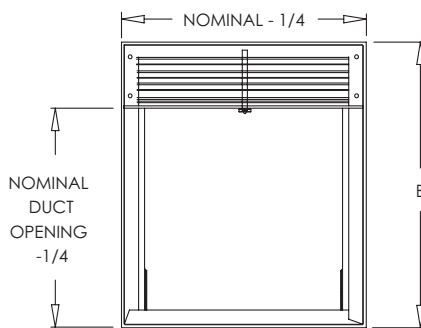

2633 & 2634

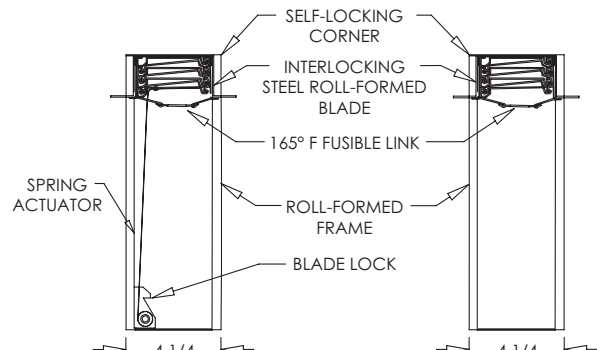

2634

2633

4 IN. CURTAIN TYPE



2650 Series Round Out-of-Airstream 1 1/2 Hour Rated Fire Damper

Standard Features:

- Spring actuated curtain-type fire damper with 2 1/4" round connection for horizontal or vertical mount
- 4 1/4" standard roll formed out-of-airstream frame
- Designed for use in walls, floors and partitions with fire resistance ratings of 2 hours or less (for ceiling application, see pages 184–188)
- UL listed and tested in accordance with UL Standard 555
- 1 1/2 hour fire resistance rating
- Building materials rated 2 Hours or less
- CSFM California State Fire Marshal listed
- Interlocking steel roll-formed blades
- Blade lock to secure blades once product is activated
- Damper manufactured from corrosion tested galvanized mild steel (G-90)
- 165° replaceable fusible link
- Available in 4" through 52" round

Options:

- Vertical mount only without spring actuator and blade lock
MODEL: 2649
- Stainless steel
- Sleeves – see page 183



2649 & 2650 Dimensions	
Duct Size	Height (C)
4" - 7"	+1 3/4"
8" - 16"	+2 3/4"
17" - 26"	+3 3/4"
27" - 35"	+4 3/4"
36" - 44"	+5 3/4"
45" - 52"	+6 3/4"

Example: Height (C) for 20" duct would be 23 3/4"

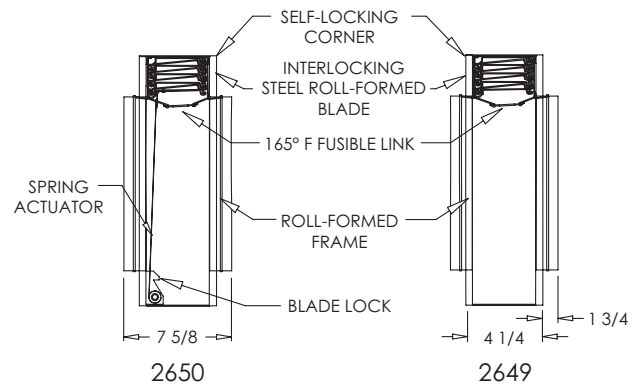
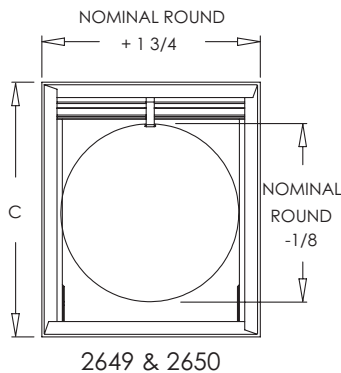
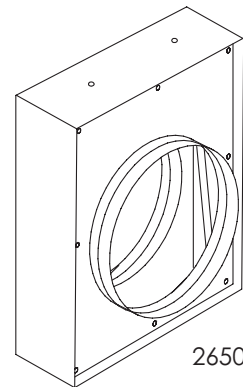

4 IN. CURTAIN TYPE



2652 Series True Round 1 1/2 Hour Rated Fire Damper

Standard Features:

- True round fire damper
- Round steel frame
- Stainless steel curtain
- Horizontal or vertical installation
- Designed for use in walls, floors and partitions with fire resistance ratings of 3 hours or less (for ceiling application, see pages 184–188)
- UL listed and tested in accordance with UL Standard 555
- 1 1/2 hour fire resistance rating
- CSFM California State Fire Marshal listed
- Damper construction meets NFPA 90A requirement
- 165° replaceable fusible link
- Available in 4" through 12" round

Options:

- Mounting Angle Ring
MODEL: MAR
- 212° fusible link

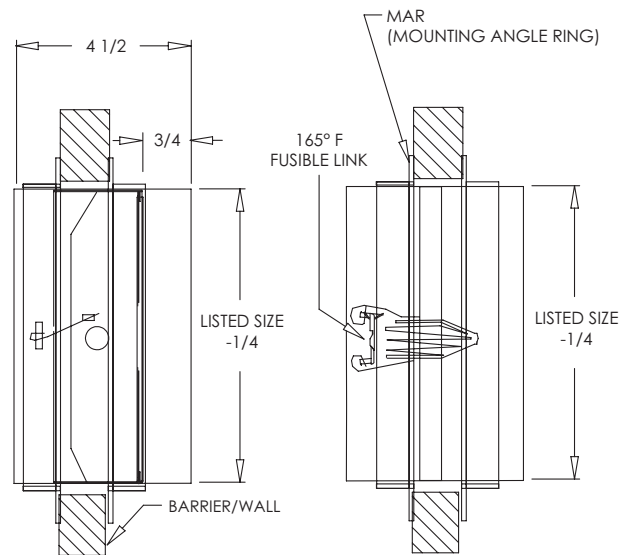

2652

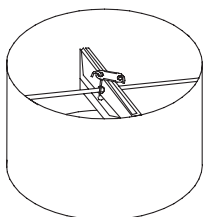

2652
OPEN POSITION

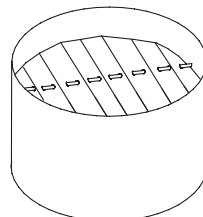

2652
CLOSED POSITION

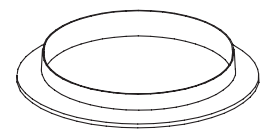

MAR
MOUNTING ANGLE RING

4 IN. CURTAIN TYPE



2661 Series 3 Hour Rated Fire Damper

Standard Features:

- Square or rectangular curtain-type fire damper for vertical mount
- 4 1/4" standard roll formed frame
- Designed for use in walls, floors and partitions with fire resistance ratings of 3 hours or less (for ceiling application, see pages 184–188)
- UL listed and tested in accordance with UL Standard 555
- 3 hour fire resistance rating
- Building materials rated 4 Hours or less
- CSFM California State Fire Marshal listed
- Interlocking steel roll-formed blade
- Damper manufactured from corrosion tested galvanized mild steel (G-90)
- 165° replaceable fusible link
- Maximum size 60" W, 60" H

Options:

- Out-of-Airstream – Maximum size 60" W, 52" H
MODEL: 2663
- Round Out-of-Airstream – Available in 4" through 52" round
MODEL: 2665
- Stainless steel
- Sleeves – see page 183
- Fractional, exact O.D. dimensions

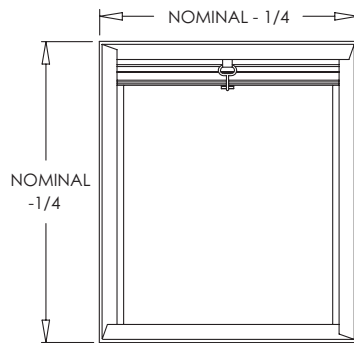
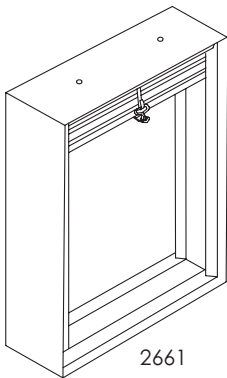
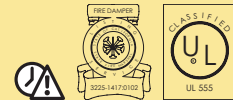

2661

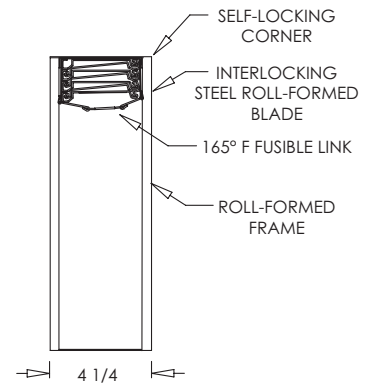

2661



2663 Frame Height	
Duct Size	Height (B)
4" - 7"	+3/4"
8" - 16"	+1 3/4"
17" - 26"	+2 3/4"
27" - 35"	+3 3/4"
36" - 44"	+4 3/4"
45" - 52"	+5 3/4"

Example: Height (B) for 20" duct would be 22 3/4"

2665 Frame Height	
Duct Size	Height (C)
4" - 7"	+1 3/4"
8" - 16"	+2 3/4"
17" - 26"	+3 3/4"
27" - 35"	+4 3/4"
36" - 44"	+5 3/4"
45" - 52"	+6 3/4"

Example: Height (C) for 20" duct would be 23 3/4"

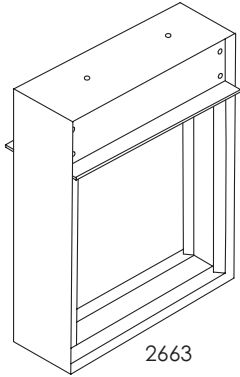

2663

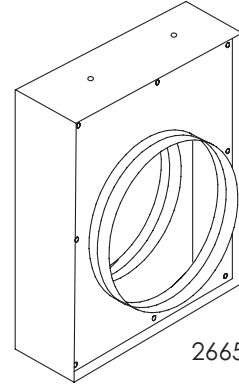

2665

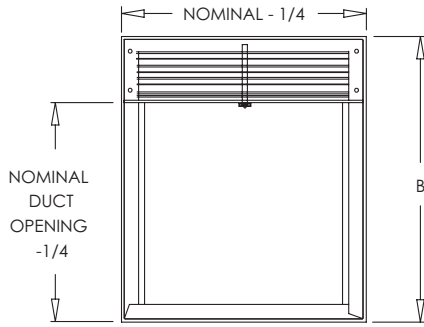

2663

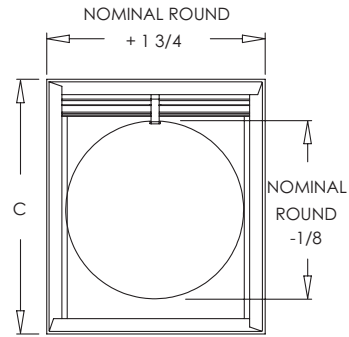

2665

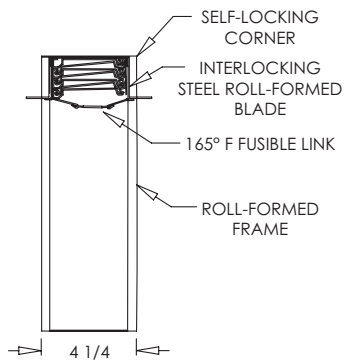

2663

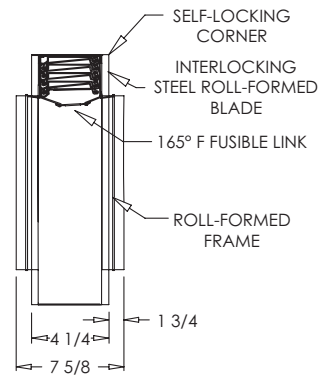

2665

FIRE DAMPER SLEEVES

Fire Damper Sleeves Sleeves for Fire Dampers: 2500 & 2600

Standard Features:

- Sleeve Type A: Square or rectangular
- Standard sleeve length 18"
- 20 gauge galvanized steel
- Mill Finish

Options:

- Gauges: 14 through 22 ga.
- Access door installed
- Retaining angles
- Available in sleeve lengths 6" through 20"
- Fractional, exact O.D. dimensions

Sleeve Types:

- Type B: Out-of-Airstream
- Type C: Square or rectangular with flange
- Type D: Square or rectangular with round collar (Note: Round collar must be 2" smaller than square sleeve dimension i.e. 10" x 10" - 8")

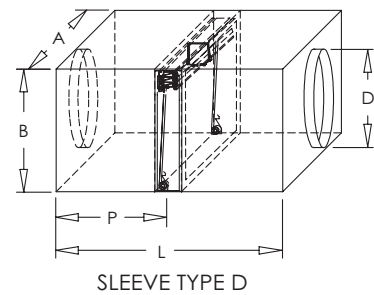
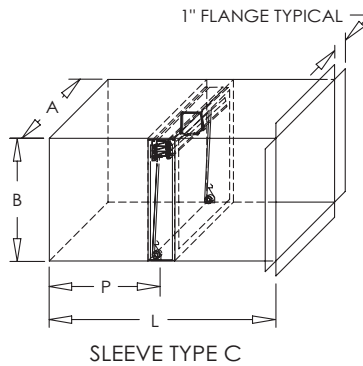
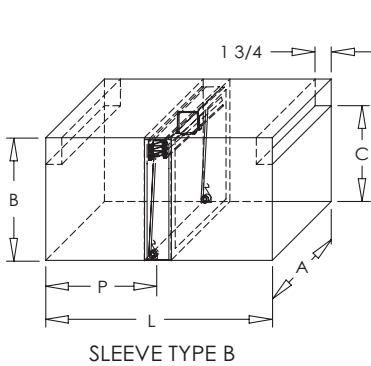
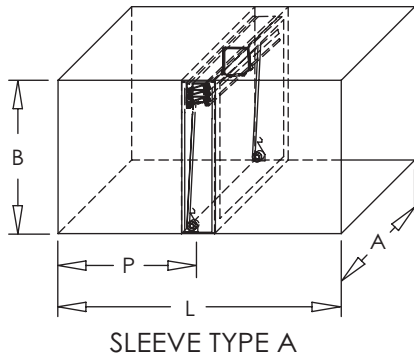

Note: Please submit drawings with required dimensions A, B, C, D, L and P specified prior to ordering.



CEILING RADIATION DAMPERS



2701 Series 3 Hour Rated Ceiling Radiation Butterfly Damper

Standard Features:

- Square or rectangular ceiling radiation butterfly damper
- Designed for protection of ceiling openings in fire rated floor/ceiling assemblies with fire resistance ratings of 3 hours or less
- UL listed and tested in accordance with UL Standard 555C
- 3 hour fire resistance rating
- Building materials rated 3 Hours or less
- CSFM California State Fire Marshal listed
- Zinc plated steel closure spring
- All steel parts with galvanized finish or zinc coating
- 22 gauge butterfly style galvanized steel blades
- 22 gauge galvanized steel roll formed frame
- Ceramic fiber blade insulation with fiberglass cover*
- 165° replaceable fusible link
- Maximum single section size 24"×24"
- Minimum size is 4"×4"

Options:

- Extended sleeve
MODEL: 2702
- 212° fusible link

* Ceramic fiber blade insulation is not U.L. required on dampers with free areas less than 80 sq. inches. Dampers with free areas greater than 80 sq. inches are constructed with ceramic fiber blade insulation.



2702 Extended Sleeve Height	
Duct Size	Height (H)
6" - 10"	8"
12" - 14"	10"
15" - 18"	12"
20" - 22"	14"
24"	15"

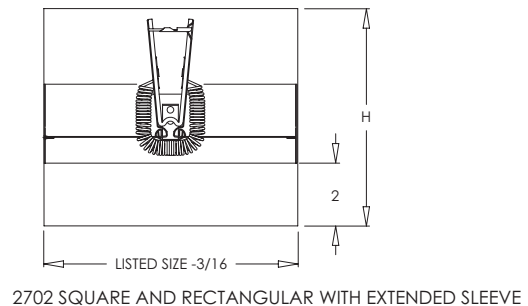
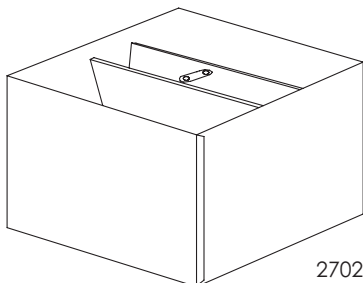
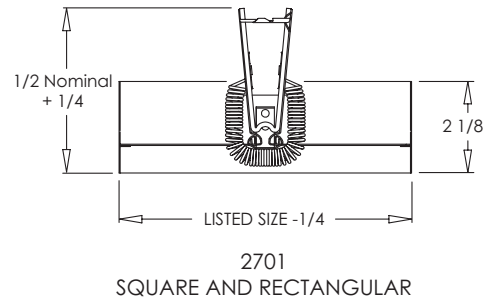
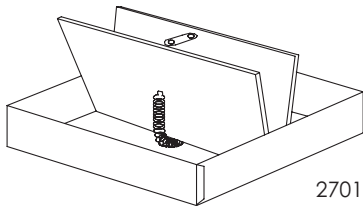

CEILING RADIATION DAMPERS



2750 Series Round 3 Hour Rated Ceiling Radiation Butterfly Damper

Standard Features:

- Round ceiling radiation butterfly damper
- Designed for protection of ceiling openings in fire rated floor/ceiling assemblies with fire resistance ratings of 3 hours or less
- UL listed and tested in accordance with UL Standard 555C
- 3 hour fire resistance rating
- Building materials rated 3 Hours or less
- CSFM California State Fire Marshal listed
- Zinc plated steel closure spring
- All steel parts with galvanized finish or zinc coating
- 22 gauge butterfly style galvanized steel blades
- 22 gauge galvanized steel roll formed frame
- Ceramic fiber blade insulation with fiberglass cover*
- 165° replaceable fusible link
- Available in 4" through 24" round

Options:

- Extended sleeve
MODEL: 2751
- 212° fusible link

* Ceramic fiber blade insulation is not U.L. required on dampers with free areas less than 80 sq. inches. Dampers with free areas greater than 80 sq. inches are constructed with ceramic fiber blade insulation.



2751 Extended Sleeve Height	
Duct Size	Height (H)
4" - 10"	8"
12" - 14"	10"
15" - 18"	12"
20" - 22"	14"
24"	15"

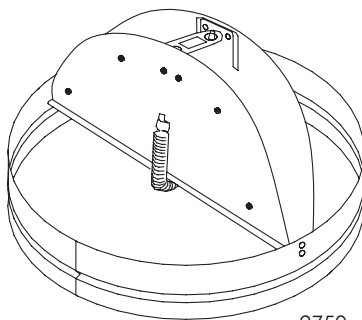

2750
ROUND

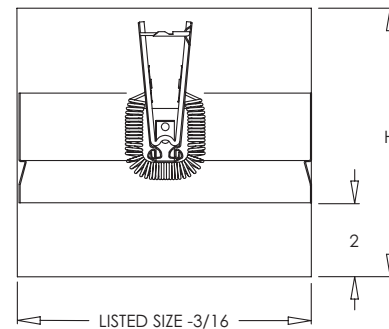

2751
ROUND WITH EXTENDED SLEEVE

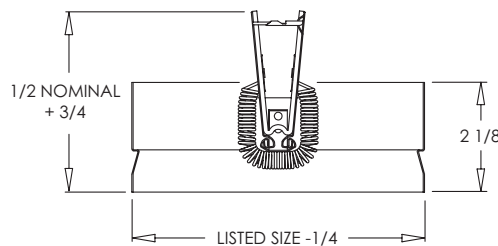

2750
ROUND

CEILING RADIATION DAMPERS



2700CBA Series 1 Hour Rated Ceiling Radiation Damper with Register Box Assembly

Standard Features:

- Factory assembled plenum box with side outlet and square or rectangular ceiling radiation damper
- UL rated for floor/ceiling and roof/ceiling wood truss assemblies L-521, L-528, L-546, P-522, L-563, L579 and P-544 types
- Meets UL263 and NFPA 90A requirements
- CSFM California State Fire Marshall listed

Ceiling Radiation Damper:

- 165° fusible link
- 22 gauge galvanized steel blades with ceramic fiberglass cover*
- Roll formed 22 gauge galvanized steel frame

Plenum Box:

- Plenum outer box made of 28 gauge galvanized steel
- Roll formed 28 gauge galvanized steel collar with 1/4" bead
- Fiberglass duct board 1-1/2" thick (R6)
- Minimum size 4" x 4" x 2" (collar)
- Maximum size 16" x 16" x 12" (collar)

Options:

- Extended length drywall flange
- Stainless steel

* Ceramic fiber blade insulation is not required on dampers with areas less than 80 sq. in. Dampers with free areas greater than 80 sq. in. will be constructed with ceramic fiber blade insulation.

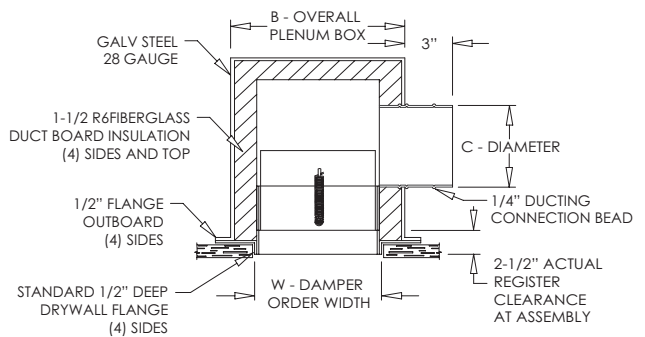
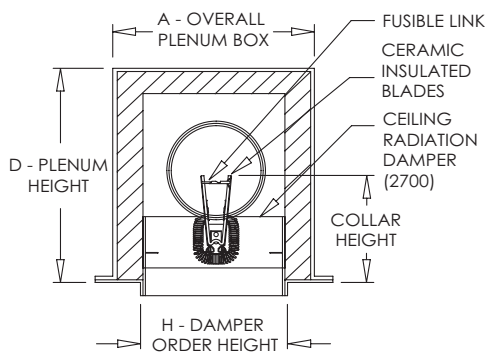
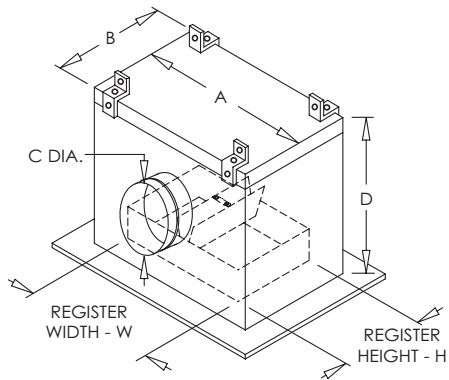

CEILING RADIATION DAMPERS

2750CBA Series 1 Hour Rated Round Ceiling Radiation Damper with Register Box Assembly

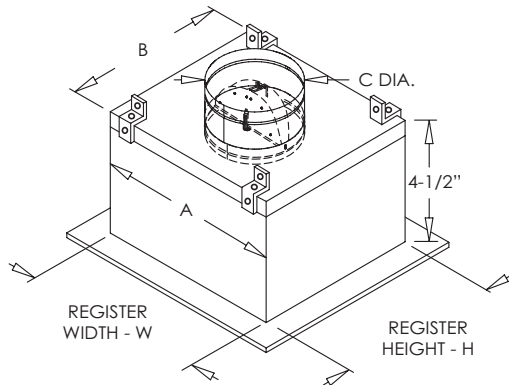

Standard Features:

- Factory assembled plenum box with top outlet and round ceiling radiation damper
- UL rated for floor/ceiling and roof/ceiling assemblies L546, L521 and P522
- Meets UL263 and NFPA 90A requirements
- CSFM California State Fire Marshall listed

Ceiling Radiation Damper:

- 165° fusible link
- 22 gauge galvanized steel blades with ceramic fiberglass cover*
- Roll formed 22 gauge galvanized steel frame

Plenum Box:

- Plenum outer box made of 28 gauge galvanized steel
- Roll formed 28 gauge galvanized steel collar with 1/4" bead
- Fiberglass duct board 1-1/2" thick (R6)
- Minimum size 7"×7"×4" (collar)
- Maximum size 16"×16"×12" (collar)

Options:

- Extended length drywall flange
- Stainless steel

* Ceramic fiber blade insulation is not required on dampers with areas less than 80 sq. in. Dampers with free areas greater than 80 sq. in. will be constructed with ceramic fiber blade insulation.

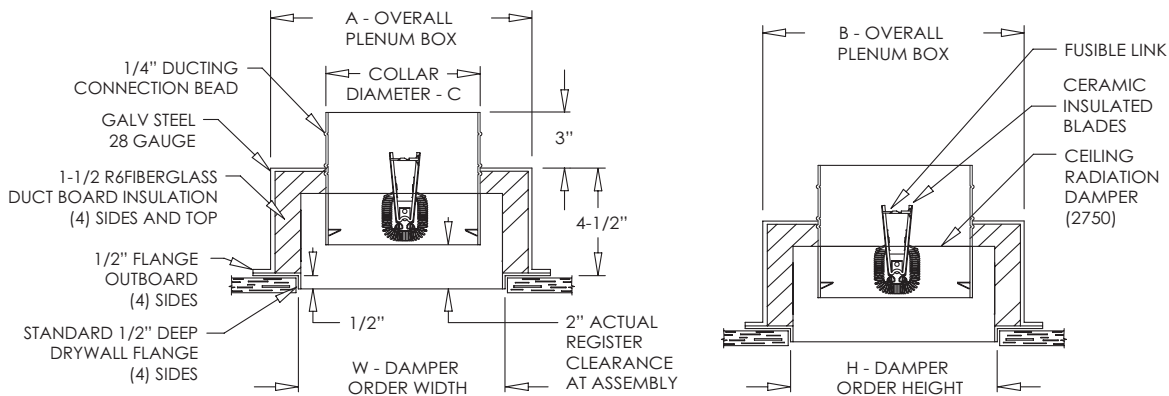
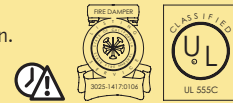

CEILING RADIATION DAMPERS



2720 Series 3 Hour Rated Ceiling Radiation Curtain-Type Damper

Standard Features:

- Square or rectangular ceiling radiation curtain-type damper for horizontal mount
- Designed for protection of ceiling openings in fire rated floor/ceiling assemblies with fire resistance ratings of 3 hours or less
- UL listed and tested in accordance with UL Standard 555C
- 3 hour fire resistance rating
- Building materials rated 3 Hours or less
- CSFM California State Fire Marshal listed
- 22 gauge steel blades with insulated blanket
- Steel riveted and metal formed assembly
- Negator stainless steel closure springs mounted on spring pin brackets
- 165° replaceable fusible link
- Minimum size 4" x 4"
- Maximum size 14" x 14"

Options:

- 212° fusible link

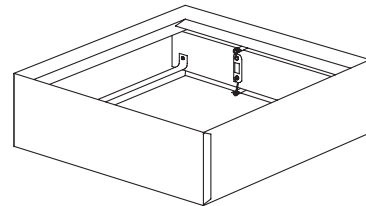
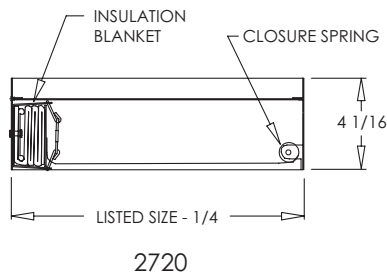

FIRE RATED T-BARS

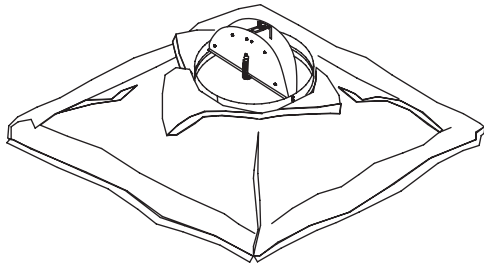

FR Series T-Bar Ceiling Air Diffusers and Returns with UL Fire Resistance Classification

Standard Features:

- T-Bar FR assembly includes 2750 Series Ceiling Radiation Damper (see page 187) and TTB Series Thermal Blanket (see page 197)
- UL listed fire resistance T-Bars

Available on the following products:

- 104 FR and 104-0 FR – see page 20 for general product information
- 104P FR – see page 36 for general product information
- 700MA FR – see page 14 for general product information
- 700CB FR and 700CB-0 FR – see page 17 for general product information
- 700DVD FR and 700DVD-0 FR – see page 22 for general product information
- HVD FR – see page 26 for general product information
- HVL FR – see page 28 for general product information
- HL FR – see page 30 for general product information
- 825CB FR and 825MA FR – see page 38 for general product information
- 780 FR – see page 34 for general product information
- 830 FR – see page 43 for general product information



Maximum Product Height	
Damper Size	Height (A)
6"	6 1/2"
7"	7"
8"	7 1/2"
9"	8"
10"	8 1/2"
12"	9 1/2"
14"	10 1/2"
16"	11 1/2"

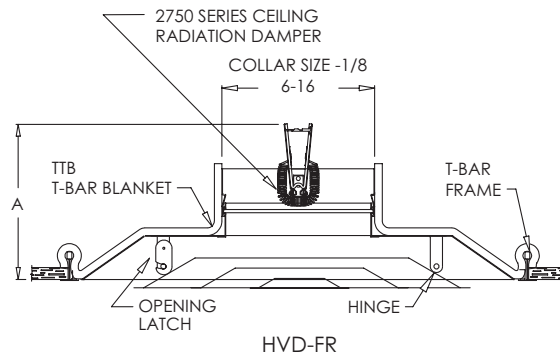

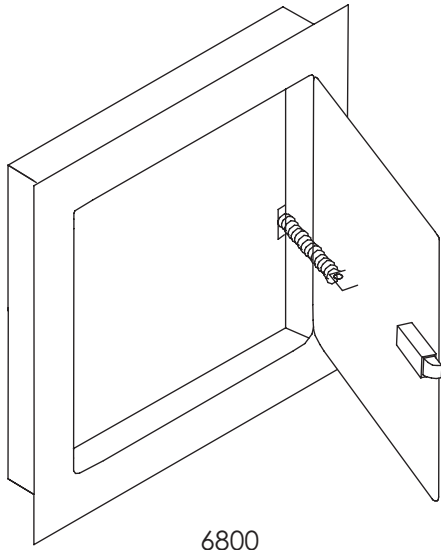

6800

6800 Series Fire Rated Wall Access Door

Standard Features:

- UL listed and tested with fire resistance rating for 1 1/2 hours
- 16 gauge galvanized steel door and frame construction
- Door has heavy duty spring closure for positive latching when panel closes
- Exterior recessed latch is operated using a ring attached to the sliding bolt
- Masonry anchors and bolt holes on frame for installation in various types of wall construction
- Concealed hinge
- Available 8×8 through 36×48
- Prime Coat Finish

Options:

- Stainless steel
MODEL: 6800-SS

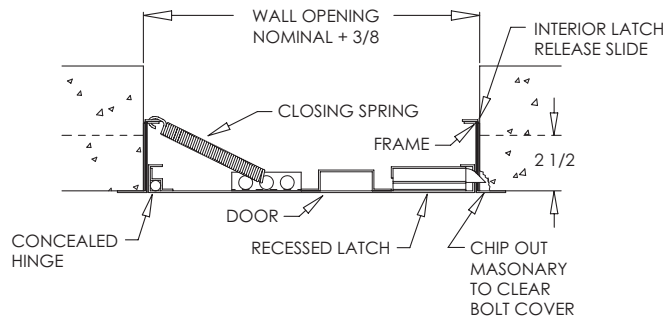
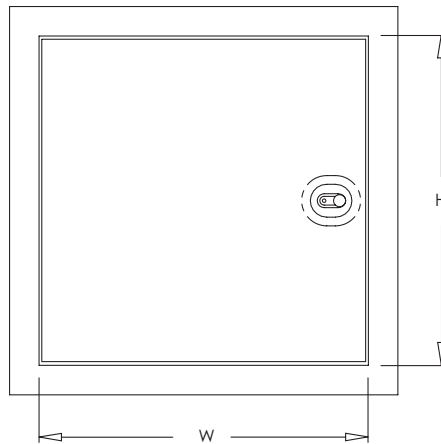

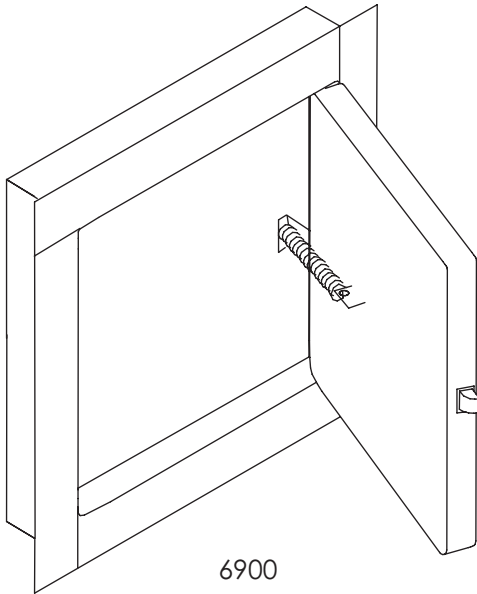

6900

6900 Series Fire Rated Ceiling Access Door

Standard Features:

- UL listed and tested with fire resistance rating for 1 1/2 hours
- Rated by Warnock Hersey for up to 3 hours in ceilings and up to 2 hours in walls*
- 20 gauge phosphate-treated steel door
- 16 gauge phosphate-treated steel frame
- Door has heavy duty spring closure for positive latching when panel door closes
- 2" insulation in door
- Exterior recessed latch is operated using a ring attached to the sliding bolt
- Interior latch release slide enables door to be opened from inside
- Continuous piano type hinge parallel to longest dimension
- Available 8×8 through 24×36
- Prime Coat Finish

* Hour rating depends both on materials used in construction and the mounting application (i.e. ceiling versus wall mount).

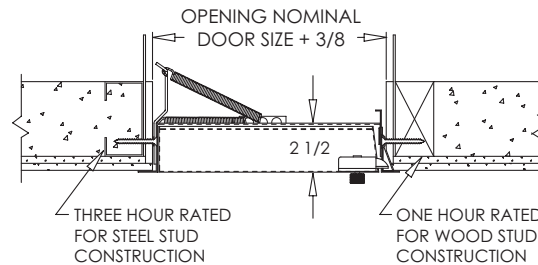
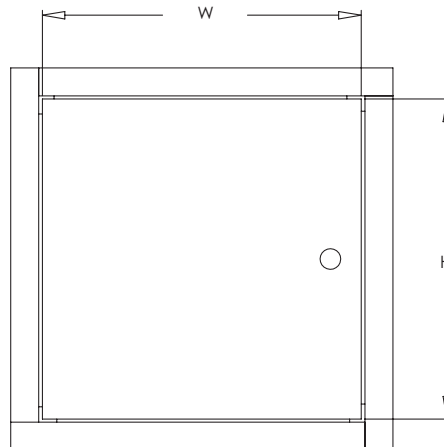
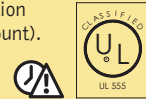

COMBINATION FIRE-SMOKE DAMPER

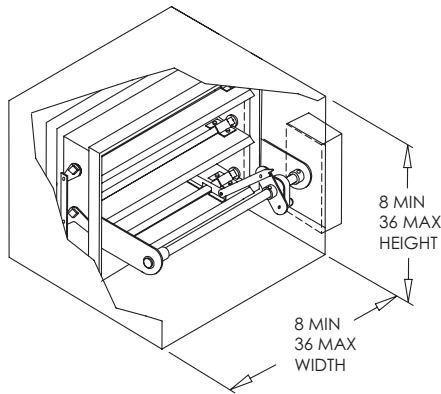

Specifications	
Max. Static Pressure	To 4.0" W.G.
Temperature Ratings	250°F – 350°F
Maximum Velocity	To 2000 FPM
Fire Duration Rating	1 1/2 Hour

FSD-111-2 Series 1 1/2 Hour Fire & Smoke Damper

Standard Features:

- Class 2 – low leakage
- Sleeve Type A: 20 gauge 18" sleeve
- 120V actuator mounted (position shown in drawing)
- Horizontal (floor installation) or vertical (wall installation) installation
- UL and CSFM California State Fire Marshall listed
- Parallel blade operation
- Power open/spring closure
- 16 gauge galvanized steel channel frame
- 16 gauge galvanized triple vee formed blades
- Sintered bronze, oil impregnated bearings
- Axles: 1/2" square zinc plated steel studs
- Linkage: .12 × .50 zinc plated steel concealed in channel frame
- Jackshaft: 1/2" diameter zinc plated steel with jackshaft connector coupling
- Caulking UL approved silicone sealants: Dow Corning RTV-732, 999A, GE-1200
- Blade Seals: 60-65 Durometer Silicone rubber with laminated acrylic adhesive permanently bonded to blade edges
- Jamb Seals: Corrosion resistant stainless steel
- R Stat: Resettable, reusable thermal disc, fixed setting of 165°
- Minimum size 8"×8"
- Maximum size 36"×36"

Options:

- Class 1 – Ultra Low Leakage fire & smoke damper (FSD-111-1)
 - Minimum size: 12"×8"
 - Maximum size: 24"×24"
- Class 1 – Ultra Low Leakage smoke only damper (SD-333-1)
- Class 2 – Low Leakage smoke only damper (SD-333-2)
- Stainless Steel
- 1 1/2 hour rated motorized 24v actuator fire damper (FD-555)
- Pneumatic actuator
- Internal mount actuator
 - Minimum damper size: 8"×8"
 - Minimum sleeve length: 25"
- Sleeves – see page 194



Fire/Smoke Damper Free Area Conversion Chart (1/FA)

Height in Inches	Width in Inches								
	8	12	16	20	24	28	30	32	36
8	4.75	2.85	2.05	1.60	1.30	1.20	1.10	1.05	1.00
10	4.00	2.35	1.70	1.35	1.10	0.92	0.85	0.83	0.81
12	3.35	2.05	1.45	1.15	0.92	0.78	0.73	0.71	0.65
14	2.60	1.60	1.15	0.88	0.72	0.59	0.57	0.56	0.50
16	2.20	1.35	0.93	0.72	0.59	0.50	0.47	0.46	0.40
20	1.70	1.00	0.73	0.57	0.47	0.39	0.37	0.35	0.31
24	1.40	0.84	0.60	0.47	0.38	0.33	0.30	0.29	0.25
28	1.15	0.68	0.49	0.38	0.31	0.27	0.25	0.23	0.21
32	1.00	0.60	0.43	0.33	0.28	0.23	0.22	0.20	0.18
36	0.88	0.53	0.38	0.30	0.24	0.21	0.19	0.18	0.16

Performance Notes:

1 Free area factors listed are for standard Type A sleeves. For Type D style sleeves, free area conversion number is equal to 1/nominal duct area.

CORRIDOR FIRE-SMOKE DAMPER

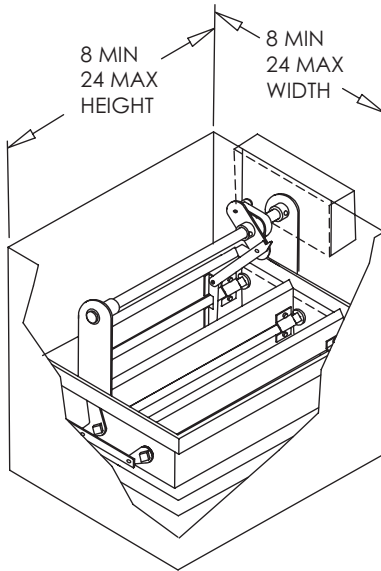

Specifications	
Max. Static Pressure	To 4.0" W.G.
Temperature Ratings	250°F – 350°F
Maximum Velocity	To 2400 FPM
Fire Duration Rating	1 Hour

CFSD-222-2 Series 1 Hour Corridor Fire & Smoke Damper

Standard Features:

- Class 2 – low leakage
- Sleeve Type A: 20 gauge 18" minimum sleeve length
- 120V actuator mounted (position shown in drawing)
- Horizontal mount for tunnel corridor installation
- UL listed and tested in accordance with UL Standard 555 and UL Standard 555S
- Fire resistance rated 1 Hour
- CSFM California State Fire Marshall listed
- Parallel blade operation
- Power open/spring closure
- 16 gauge galvanized steel channel frame
- 16 gauge galvanized triple vee formed blades
- Sintered bronze, oil impregnated bearings
- Axles: 1/2" square zinc plated steel studs
- Linkage: .12 x .50 zinc plated steel concealed in channel frame
- Jackshaft: 1/2" diameter zinc plated steel with jackshaft connector coupling
- Caulking UL approved silicone sealants: Dow Corning RTV-732, 999A, GE-1200
- 165° replaceable fusible link
- Minimum size 8" x 8"
- Maximum size 24" x 24"

Options:

- Class 1 – Ultra Low Leakage fire smoke corridor damper (CFSD-111-1)
 - Minimum size: 12" x 8"
 - Maximum size: 24" x 24"
- Class 1 – Ultra Low Leakage smoke only corridor damper (CSD-444-1)
- Class 2 – Low Leakage smoke only corridor damper (CSD-444-2)
- Stainless Steel
- 24v actuator
- Pneumatic actuator
- Internal mount actuator
 - Minimum damper size: 8" x 8"
 - Minimum sleeve length: 25"
- Retaining angles
- Sleeves – see page 194



FIRE SMOKE DAMPER SLEEVES

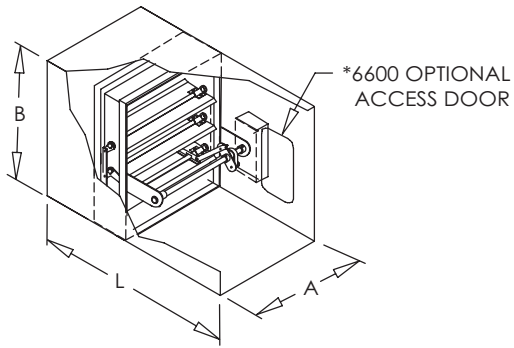

SLEEVE TYPE A

Fire & Smoke Damper Sleeves Sleeves for Fire & Smoke Dampers: FSD-111, SD-333, FD-555, CFSD-222, & CSD-444

Standard Features:

- Sleeve Type A: Square or rectangular
- 20 gauge galvanized steel
- 18" minimum length
- Mill finish

Options:

- Gauges: 14 through 22 ga.
- Access door installed (6600), minimum 25" sleeve length required (Note: Minimum size damper 10" x 10" i.e. FSD-111-2-10" x 10")
- Duct smoke detector (D4120), minimum 25" sleeve length required
- Retaining angles
- Fractional, exact O.D. dimensions

Sleeves Types:

- Type C: Square or rectangular with flange
- Type D: Square or rectangular with round collar

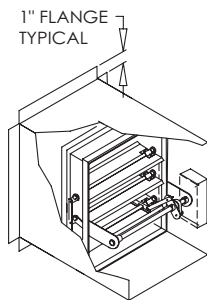

SLEEVE TYPE C

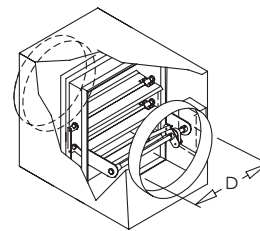

SLEEVE TYPE D

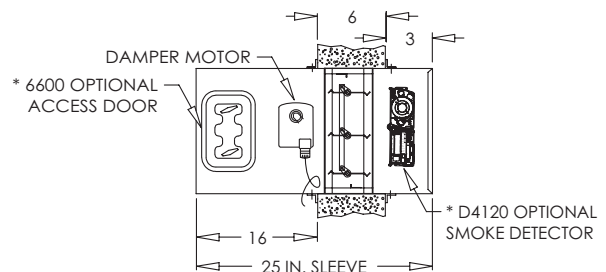
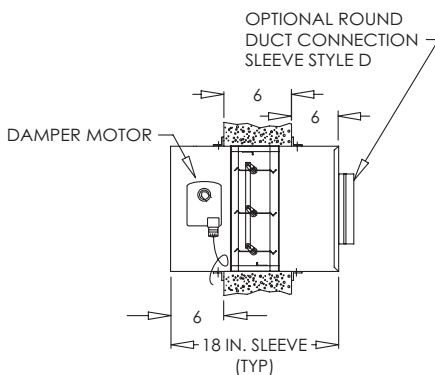

DYNAMIC FIRE DAMPER

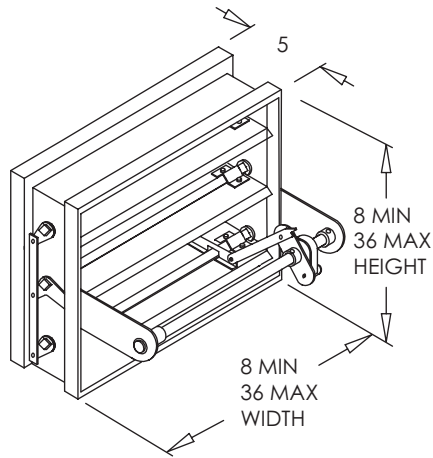

2800 Series 1 1/2 Hour Dynamic Fire Damper

Standard Features:

- Horizontal or vertical installation (not for ceiling application, see 2700 Series)
- Designed for use in walls, floors and partitions with fire resistance ratings of 2 hours or less (for ceiling application, see 2700 Series)
- UL listed and tested in accordance with UL Standard 555
- Fire resistance rated 1 1/2 Hours
- CSFM California State Fire Marshal listed
- Parallel blade operation
- 16 gauge galvanized triple vee formed blades
- 16 gauge galvanized steel channel frame
- Sintered bronze, oil impregnated bearings
- Axles: 1/2" square zinc plated steel studs
- Linkage: .12 x .50 zinc plated steel concealed in channel frame
- Jackshaft: 1/2" diameter zinc plated steel with jackshaft connector coupling
- Caulking UL approved silicone sealants: Dow Corning RTV-732, 999A, GE-1200
- 165° replaceable fusible link
- Minimum size 8" x 8"
- Maximum size 36" x 36"

Options:

- Stainless Steel
- Sleeves – contact factory

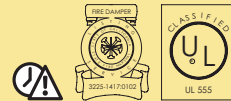

FIRE SMOKE ACCESSORIES

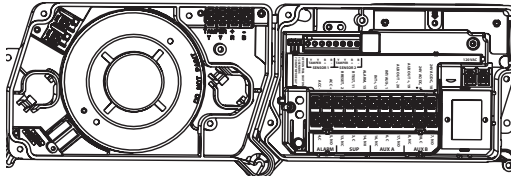

D4120 Innovair Duct Smoke Detector

Standard Features:

- 4-wire low profile duct smoke detector
- UL, CSFM California State Fire Marshall, and FM listed
- Outside mounting tabs
- Sampling tube covers up to 24" duct
- Built-in reset button
- Interconnectable for multi-fan shutdown (up to ten air handlers)
- 24 VAC/DC or 120/240 VAC operation
- Easy mounting to round or rectangular ducts from 1' to 12' wide
- Clear cover for convenient visual inspection

Options:

- Remote test station with key lock
- Remote annunciator alarm LED
- Piezo annunciator with power & alarm LED
- Multi-signaling accessory
- Multi-alert sounder
- Multi-alert add-on strobe accessory

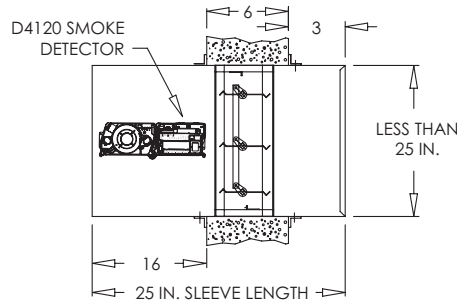

SMOKE DETECTOR MOUNTING ORIENTATION FOR DAMPERS LESS THAN 25 INCHES IN HEIGHT

FIRE SMOKE ACCESSORIES



U.L. Designated Fusible Links for series 2500 & 2600*

- 65° fusible link, small
MODEL: #50
- 165° fusible link, large
MODEL: #51
- 212° fusible link, small
MODEL: #52
- 212° fusible link, large
MODEL: #53
- 180° fusible link, small
MODEL: #54
- 180° fusible link, large
MODEL: #55

* Note: These fusible links are not to be used for smoke/fire dampers. See below for smoke/fire damper replacement links.

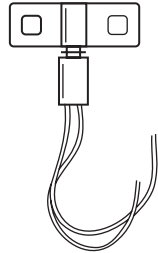

ETL Link

- A multi-purpose, dual responsive fusible link specifically designed to substitute for ordinary links and/or other actuators in existing and new installations of fire dampers and fire doors.
MODEL: #56

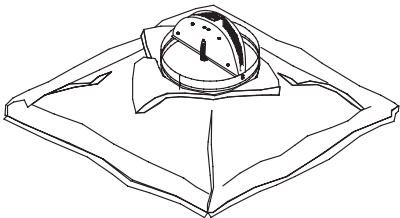

Fire Rated T-Bar Blanket

- Thermal Blanket – 3 hour rated, 28 × 28, 1/4 thickness, #6 density ceramic fiber with woven mesh screen and starter hole
MODEL: TTB



Fusible Links for series FSD, CFSD & 2800

- 165° fusible link, small
MODEL: #50A

For 2800 Dynamic Dampers only:

- 212° fusible link, small
MODEL: #52A
- 265° fusible link, small
MODEL: #54A



FIRE SMOKE ACCESSORIES

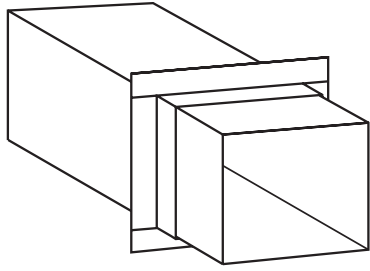

Rapid Mounting Angle for Fire Dampers

- UL approved for all fire, smoke/fire damper installations in metal studs and concrete/masonry walls and floors
- Rapid Mounting Angle wraps around the sleeve, completing installation from one side
- Designed for field mounting

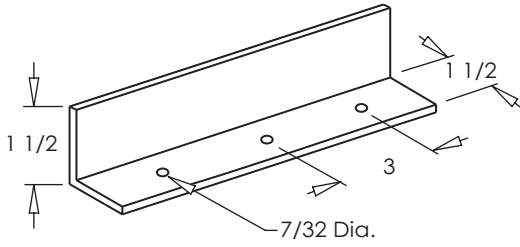

Retaining Angle for Fire Dampers

- 1 1/2" x 1 1/2" 16 gauge cold formed galvanized angle
- Pre-punched 7/32 holes for faster fastening of sleeve angle to sleeve
- Hole spacing is 3" on center
- 4 piece set

OVERVIEW

Shoemaker offers a complete line of security grilles for minimum and maximum security institutions, as well as psychiatric facilities, which require secure HVAC outlets. These heavy duty security grilles are designed to provide superior performance in both supply and return applications without compromising security and/or safety. They are available in steel, stainless steel, and aluminum and are offered with a wide variety of options. If you do not see the option that you require, please contact us.

Product Key

The product key located on the bottom of each page uses symbols to note options, features and services that are found repeatedly throughout this section of the catalog:



EXTENDED LEADTIME

Product not available in our standard lead time. Contact customer service for lead time quote.

SECURITY DIFFUSERS & GRILLES



1401 Series Bar Type Security Grille

Standard Features:

- Designed for supply or return
- 14 gauge steel construction
- 1" flanged face plate stitch welded to sleeve
- Blades at 0° deflection: 1/8" × 1/2" blades on 1/2" centers
- Vertical support bars on 6" centers
- Blades and supports individually welded to sleeve
- #2 mesh woven wire screen: 10 gauge .135" dia. steel wire on 1/2" centers
- Standard 12" sleeve
- White

Options:

- All aluminum construction
MODEL: 1401-A
- All stainless steel mill finish
MODEL: 1401-SS
- Countersunk mounting holes for flush appearance with color matching Tamper Proof Screws
- Without #2 mesh woven wire screen
- Face plate material – 12 ga., 10 ga. or 3/16" steel
- Sleeve material – 12 ga., 10 ga. or 3/16" steel
- Sleeve length (minimum 2 1/2")
- Blade deflection - 15° or 40°
- See pages 211–212 for additional options and details

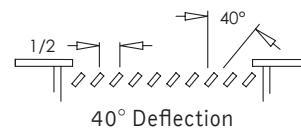
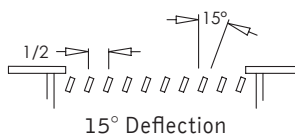
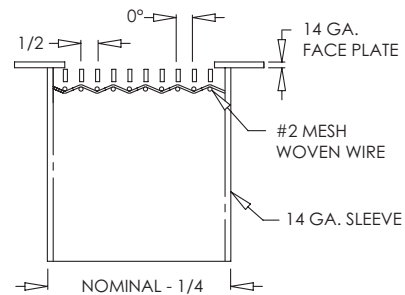
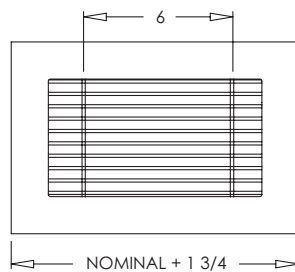

SECURITY DIFFUSERS & GRILLES



1402 Series Face Plate / Screen / Backer Plate Security Grille

Standard Features:

- Designed for supply or return
- 3/16" steel construction
- 1" flanged face plate with 2" x 2" holes with 1" fret stitch welded to sleeve
- Matching backer plate of 3/16" steel stitch welded inside sleeve
- #2 mesh woven wire screen: 10 gauge .135" dia. steel wire on 1/2" centers
- Standard 12" sleeve
- White

Options:

- All aluminum construction
MODEL: 1402-A
- All stainless steel mill finish
MODEL: 1402-SS
- Countersunk mounting holes for flush appearance with color matching Tamper Proof Screws
- Face plate material – 14ga., 12 ga., 10 ga. or 1/4" steel
- Sleeve material – 14 ga., 12 ga., or 10 ga. steel
- Sleeve length (minimum 2 1/2")
- See page 211–212 for additional options and details

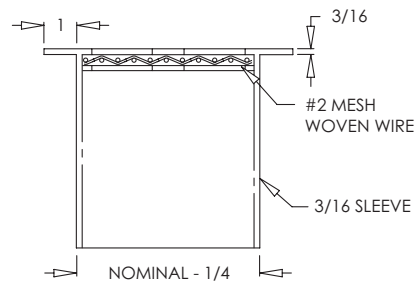
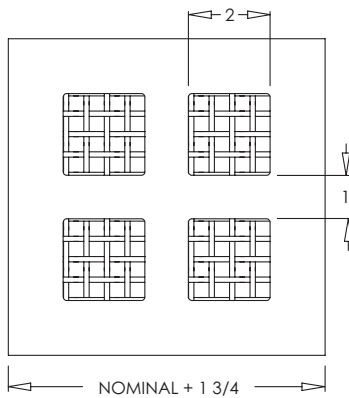

SECURITY DIFFUSERS & GRILLES



1404 Series Wire Screen Face Security Return

Standard Features:

- Designed for return application
- 10 gauge steel construction
- 1" flanged face plate stitch welded to sleeve
- #2 mesh woven wire screen: 10 gauge .135" dia. steel wire on 1/2" centers
- Support bars 3/4" dia. A-36 mild steel on 6" centers vertically and 12" centers horizontally
- Standard 12" sleeve
- White

Options:

- All aluminum construction
MODEL: 1404-A
- All stainless steel mill finish
MODEL: 1404-SS
- Countersunk mounting holes for flush appearance with color matching Tamper Proof Screws
- Face plate material – 14ga., 12 ga., or 3/16" steel
- Sleeve material – 14ga., 12 ga., or 3/16" steel
- Sleeve length (minimum 4")
- See page 211–212 for additional options and details

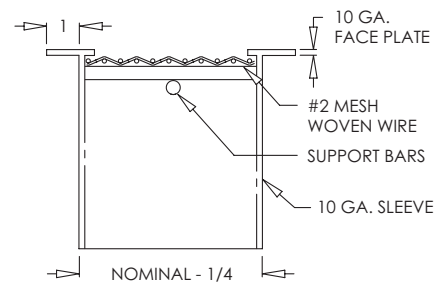
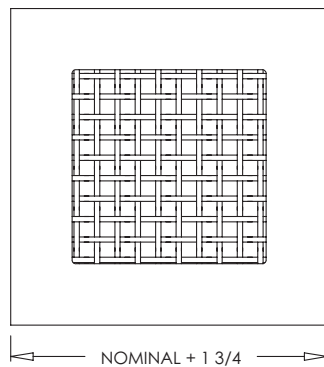

SECURITY DIFFUSERS & GRILLES

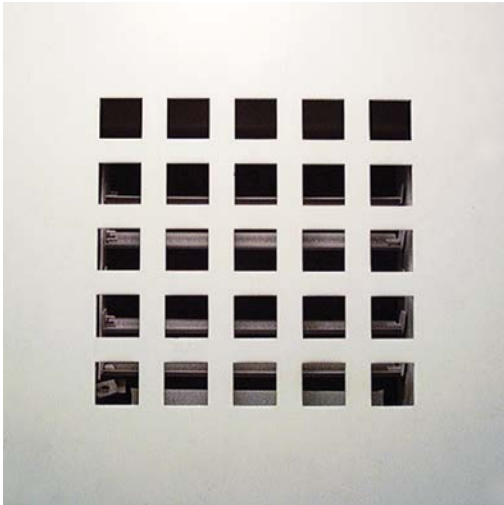

1405 Series Square Hole Lattice Face Security Grille

Standard Features:

- Designed for supply or return
- 14 gauge steel construction
- 1" flanged face plate stitch welded to sleeve
- 3/4" square holes with 1/4" frets
- Standard 12" sleeve
- White

Options:

- All aluminum construction
MODEL: 1405-A
- All stainless steel mill finish
MODEL: 1405-SS
- Countersunk mounting holes for flush appearance with color matching Tamper Proof Screws
- Hole pattern - 13/16" square holes with 3/16" frets or 1/2" square holes with 3/16" frets
- Face plate material - 12 ga., 10 ga., or 3/16" steel
- Sleeve material - 12 ga., 10 ga., or 3/16" steel
- Sleeve length (no sleeve or minimum 2 1/2")
- See page 211–212 for additional options and details

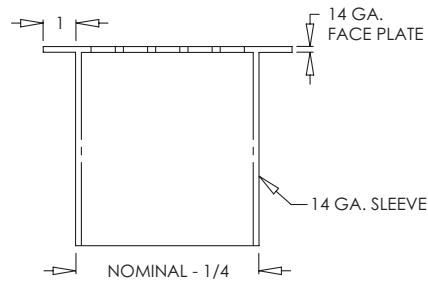
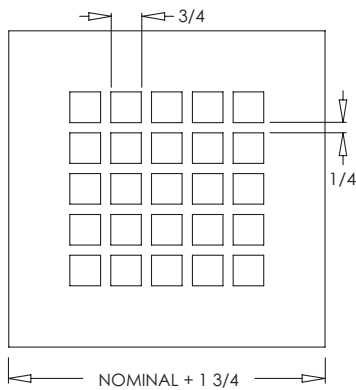

SECURITY DIFFUSERS & GRILLES

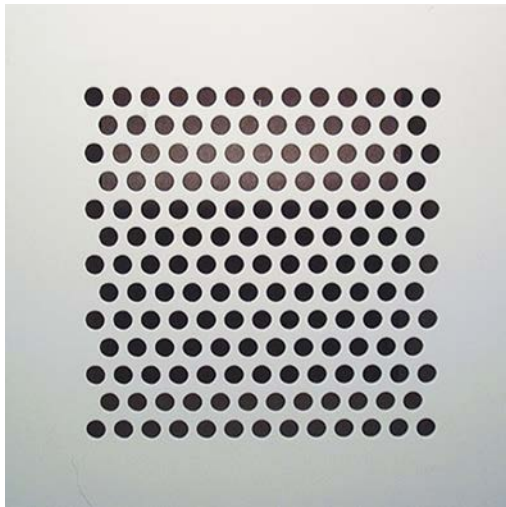

1406 Series Security Grille Perforated Face

Standard Features:

- Designed for supply or return
- 3/16" steel construction
- 1" flanged perforated face with 5/16" diameter holes on 7/16" staggered centers stitch welded to sleeve
- Standard 12" sleeve
- White

Options:

- Round perforated face and round sleeve
MODEL: 1406-R
- All aluminum construction
MODEL: 1406-A
- All stainless steel mill finish
MODEL: 1405-SS
- Countersunk mounting holes for flush appearance with color matching Tamper Proof Screws
- Hole pattern - 1/4" holes on 3/8" centers
- Face plate material - 14 ga., 12 ga., or 10 ga. steel
- Sleeve material - 14 ga., 12 ga., or 10 ga. steel
- Sleeve length (no sleeve or minimum 2 1/2")
- See page 211-212 for additional options and details

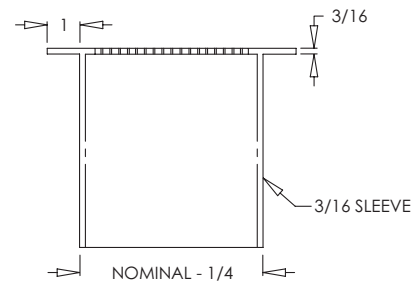
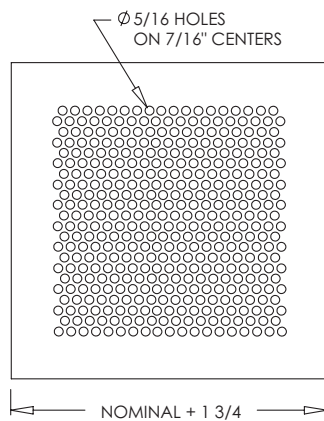

SECURITY DIFFUSERS & GRILLES

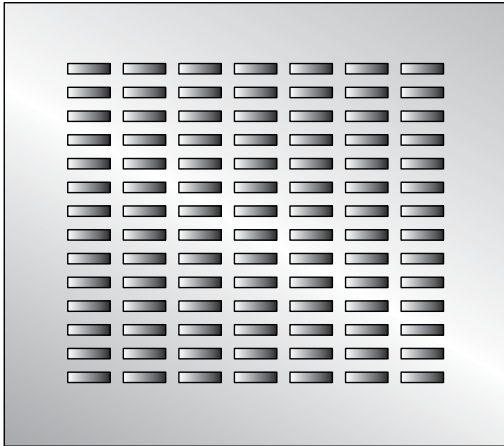

1407 Series Rectangular Hole Lattice Face Security Grille

Standard Features:

- Designed for supply or return
- 10 gauge steel construction
- 1" flanged face plate stitch welded to sleeve
- 1/4" × 1" rectangular holes with 5/16" fret
- Standard 12" sleeve
- White

Options:

- All aluminum construction
MODEL: 1407-A
- All stainless steel mill finish
MODEL: 1407-SS
- Countersunk mounting holes for flush appearance with color matching Tamper Proof Screws
- Face plate material – 14 ga., 12 ga., or 3/16" steel
- Sleeve material – 14 ga., 12 ga., or 3/16" steel
- Sleeve length (no sleeve or minimum 2 1/2")
- See page 211–212 for additional options and details

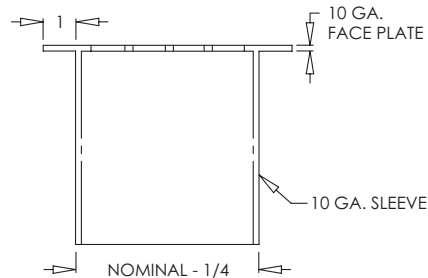
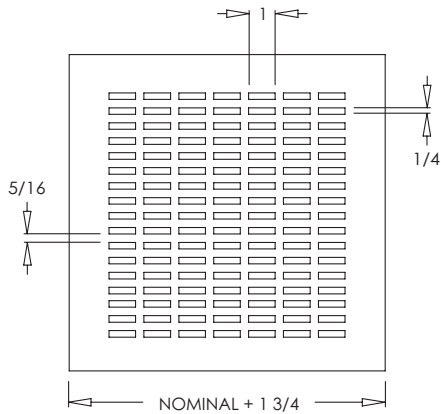

SECURITY DIFFUSERS & GRILLES



1408 Series Lattice Face Security Diffuser

Standard Features:

- Designed for supply application
- Fixed 1, 2, 3 or 4 way square steel ceiling diffuser
- 12 gauge steel security face plate of 13/16" square holes with 3/16" fret
- Available in 6"×6" through 24"×24" square neck sizes (neck sizes available in 3" increments only)
- Countersunk screw holes for flush appearance with color matching Tamper Proof Screws
- White

Options:

- Face operated Opposed Blade Damper
MODEL: 1408-0
- Return only, no core
MODEL: 1408-R
- All aluminum construction
MODEL: 1408-A
- All stainless steel mill finish
MODEL: 1408-SS
- Square to round transition collar
- 12 ga. sleeve with continuously welded or formed seams, stitch welded to diffuser neck (minimum length 4")
- Face plate material – 14 ga., 12 ga., or 3/16" steel
- Square hole size – 1/2" × 1/2" square holes with 3/16" frets or 3/4" × 3/4" square holes with 1/4" frets
- See page 211–212 for additional options and details

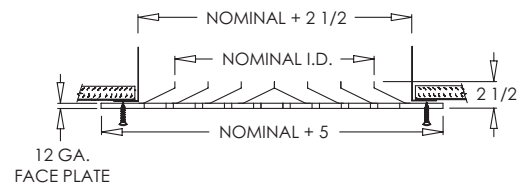
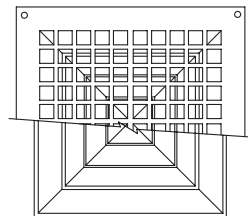
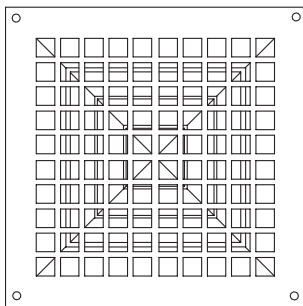

Air Patterns:

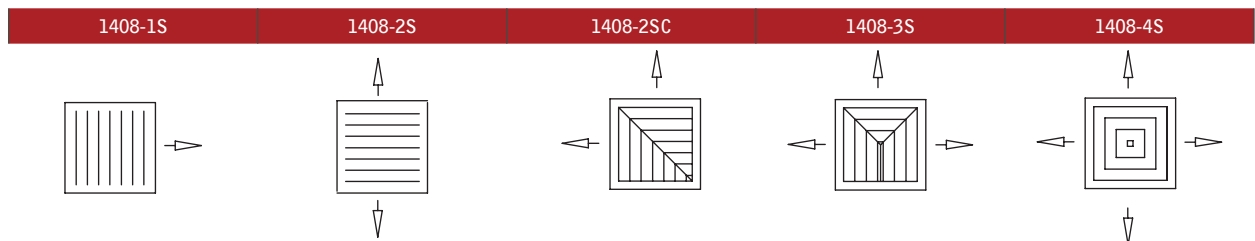

RISK RESISTANT SECURITY DIFFUSERS & GRILLES

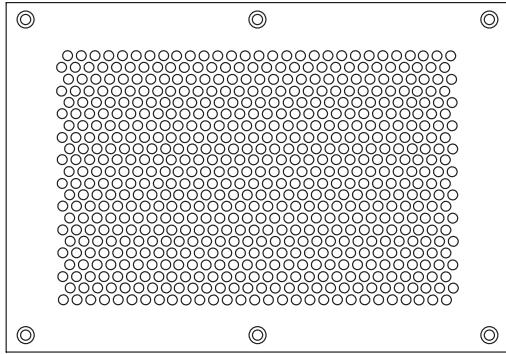

1409 Series Risk Resistant Security Grille Perforated Face

Standard Features:

- Designed for supply or return
- 14 gauge steel construction
- 1" flanged face with 3/16" diameter holes on 9/32" staggered centers
- Countersunk mounting holes in face 10" o.c. with #10 × 1-1/2" long Torx security flat head sheet metal screws
- White

Options:

- All aluminum construction
- **MODEL: 1409-A**
- Countersunk mounting holes in face 10" o.c. with #10-24 × 2" long Torx security flat head machine screws for 1-1/2" maximum ceiling thickness. 1" × 1" × 1/8" steel angle frame with matching holes and fold-over nuts. Requires 1-1/2" flange.
- Face operated Opposed Blade Damper tack welded to rear of face plate
- Hole Pattern - 3/16" holes on 1/4" centers
- Face Plate Material - 12 ga., 10 ga., or 3/16" steel

Notes:

- Complies with National Institute of Corrections recommendations and California Code of Regulations Title 24

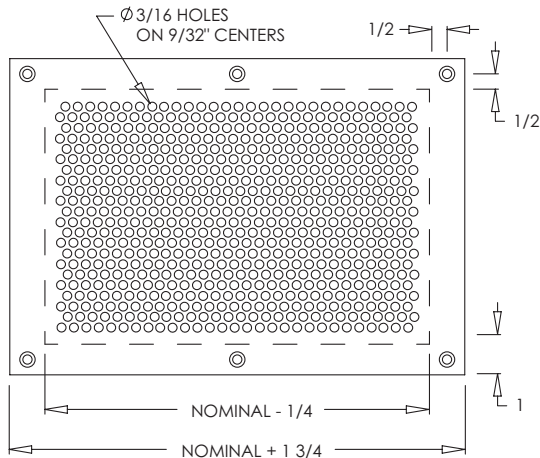

RISK RESISTANT SECURITY DIFFUSERS & GRILLES

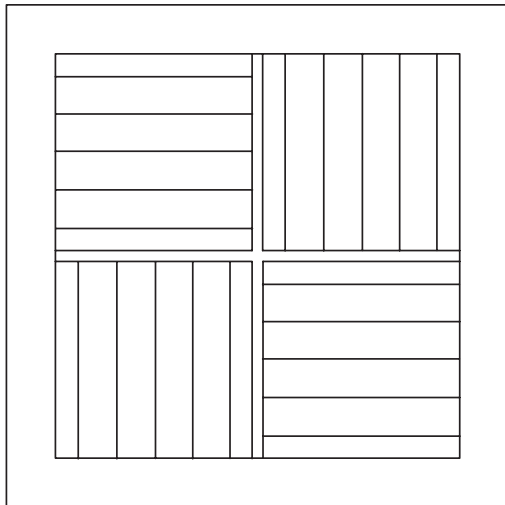

1410 Series Risk Resistant Louvered Face Security Diffuser and Sleeve

Standard Features:

- Designed for supply application
- Face and sleeve are 12 gauge hot-rolled steel
- 4-Way core has 12 gauge hot-rolled steel louvers
- Louvers formed at two 90° angles and placed on 3/8" centers
- Four loose pieces of 1-1/2" x 1-1/2" x 1/8" wall angles provided for field welding
- Bright White

Options:

- Wall angles with pre-punched mounting holes in four loose pieces for bolting, security nuts and bolts provided

Notes:

- Complies with National Institute of Corrections recommendations and California Code of Regulations Title 24

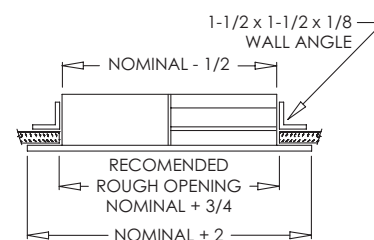
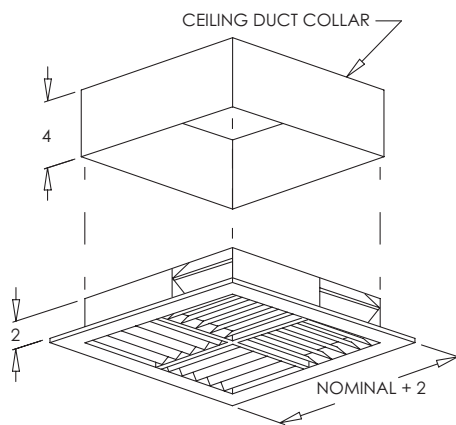

Air Patterns:

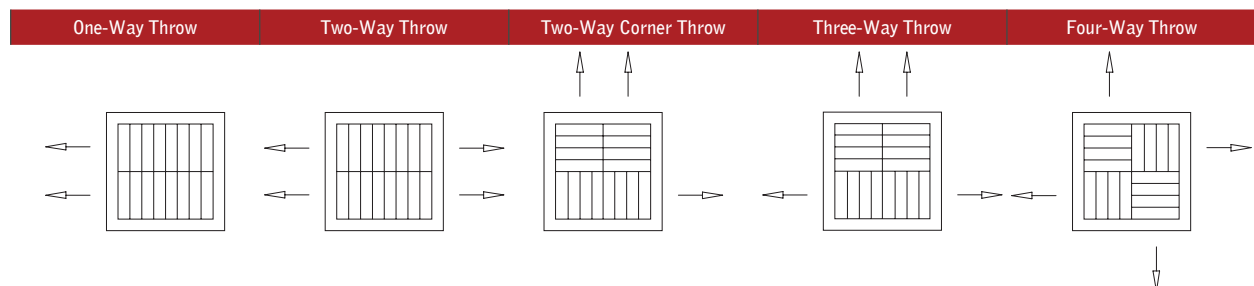

SECURITY OPTIONS

Mounting Collars & Angles

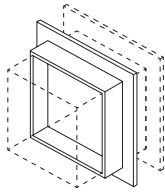

OPTION 10

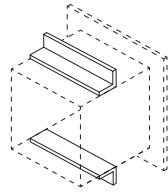

OPTION 11

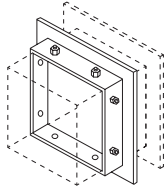

OPTION 12

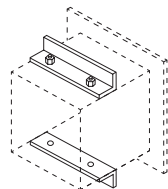

OPTION 13

- **Option 10:** Assembled outer rear 1-1/4" × 1-1/4" × 3/16" loose angle collar for welding
- **Option 11:** Assembled outer rear 1-1/4" × 1-1/4" × 3/16" loose angles for welding
- **Option 12:** Separate outer rear 1-1/4" × 1-1/4" × 3/16" loose angle collar for bolting
- **Option 13:** Separate outer rear 1-1/4" × 1-1/4" × 3/16" loose angles for bolting

Fastening Methods

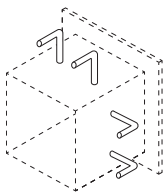

OPTION 14

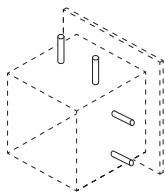

OPTION 15

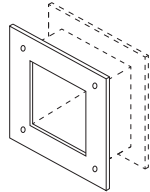

OPTION 16

- **Option 14:** Masonry Tabs - size, length and spacing as required
- **Option 15:** Masonry Rods - size, length and spacing as required
- **Option 16:** Matching rear plate with weld nuts for room to room or door grille transfer
- **Option 17:** Rear angle ring with nutsert for bolting
- **Option 18:** Countersunk screw holes in face for tamper proof screws

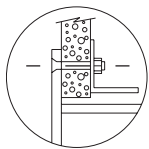

OPTION 17

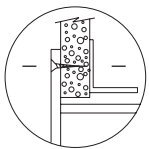

OPTION 18

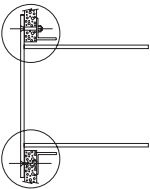

Damper and Air Deflection Options

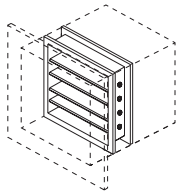

OPTION 20

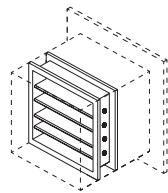

OPTION 21

- **Option 20:** Opposed Blade Damper front operated
- **Option 21:** Opposed Blade Damper rear operated
- **Option 22:** Single deflection airfoil blades, bars parallel to longest dimension
- **Option 23:** Single deflection airfoil blades, bars parallel to shortest dimension
- **Option 24:** Double deflection airfoil blades, front bars parallel to longest dimension with rear blades opposite
- **Option 25:** Double deflection airfoil blades, front bars parallel to shortest dimension with rear blades opposite
- **Note:** Options 22, 23, 24 and 25 include option 40 (10 gauge #2 mesh woven wire)

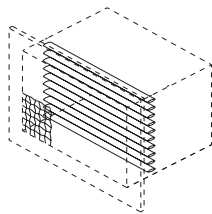

OPTION 22

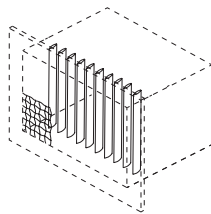

OPTION 23

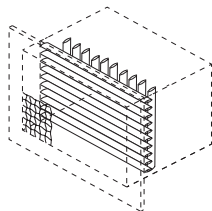

OPTION 24

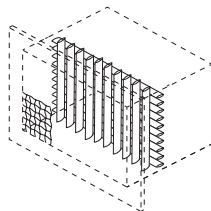

OPTION 25

SECURITY OPTIONS

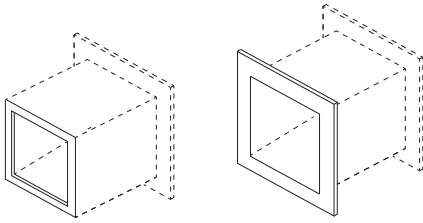

OPTION 30

OPTION 31

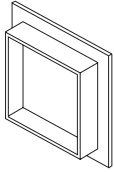

OPTION FF

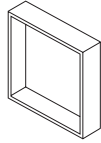

OPTION IF

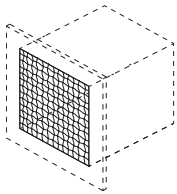

OPTION 40

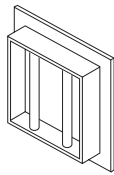

OPTION 41
Shown in FF

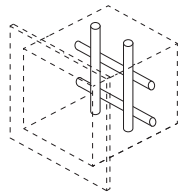

OPTION 42
Shown in sleeve

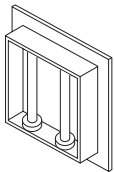

OPTION 43
Shown in IF

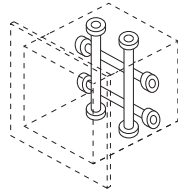

OPTION 44
Shown in sleeve

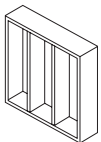

OPTION 20
Shown in IF

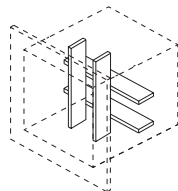

OPTION 46
Shown in sleeve

Sleeve Options

- Option 30: Bent in rear flange available all sleeves
- Option 31: Bent out rear flange available all sleeves

Barrier Frame Styles

- Option FF: Flange Frame, 2-1/2" × 2-1/2" × 1/4" angle frame
- Option IF: Interior Frame, Separate inner 2-1/2 × 3/8" flat steel frame. Can be used with barrier designs below

Barrier Design Options

- Option 40: 10 gauge #2 mesh woven wire
- Option 41: Standard round 1/2", 3/4" or 1" diameter bars welded to sleeve max. 6" vertical
- Option 42: Standard round 1/2", 3/4" or 1" diameter bars welded to sleeve at all crossings. Max. 6" vertical, 12" horizontal
- Option 43: C-61 Rockwell heat treated 1/2", 3/4" or 1" diameter bars in sockets. Maximum 6" vertical
- Option 44: C-61 Rockwell heat treated 1/2", 3/4" or 1" diameter bars in sockets. Maximum 6" vertical, 12" horizontal
- Option 45: 2-1/2" × 3/8" steel bars on max. 6" vertical centers welded to center of sleeve
- Option 46: 2-1/2" × 3/8" vertical and horizontal steel bars on max. 6" vertical, 12" horizontal centers, welded on center of sleeve and at crossings

Accessories

- Tamper Proof Screws - #10×1-1/2" sheet metal screws
Option F: Torx Center Pin
FSS: Torx Center Pin Stainless Steel



OVERVIEW

Shoemaker offers a comprehensive line of critical environment products for applications where air quality and air distribution are essential to the satisfactory outcome of the task or process being performed.

Product Key

The product key located on the bottom of each page uses symbols to note options, features and services that are found repeatedly throughout this section of the catalog:



MRI COMPATIBLE

Constructed with MRI compatible materials (standard product or available option)



EXTENDED LEADTIME

Product not available in our standard lead time. Contact customer service for lead time quote.

LAMINAR FLOW DIFFUSER

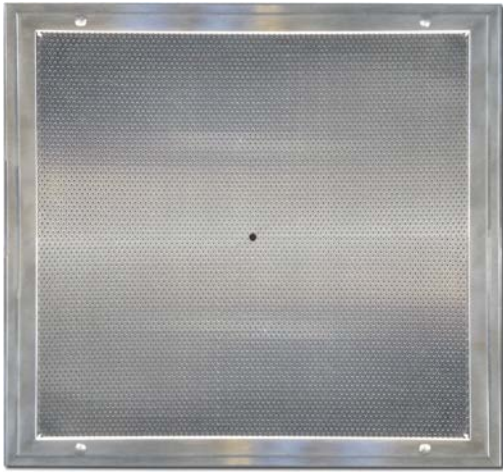

5300 Series Laminar Flow Diffuser Panel

Standard Features:

- Type 304 stainless steel
- Perforated face design has 3/32" diameter holes on 1/4" staggered centers
- 13% Free Area
- Integral pressure plate ensures true laminar airflow
- Built-in screwdriver adjustable damper disk for even distribution and field balancing accessed by removing face plug
- Removable face plate allows for easy cleaning; secured by 1/4 turn fasteners
- Safety cables to prevent dropping of face
- Round inlets for simple duct connection
- Standard unit designed for both lay-in T-Bar ceiling systems and surface mount applications
- Integral earthquake hanger tabs
- #4 satin polished finish

Options:

- HEPA Rack with 9" plenum
MODEL: 5300-HF
- Flush mount channel frame
- Type 316 Stainless
- Aluminum construction
- LED indicator light – illuminates when filter change is necessary
- Pressure ports
- Aerosol challenge manifold
- Powder coat finish

Inlet Options:

- Side Inlet
- End Inlet
- Rectangle Inlet
- Oval Inlet



5300

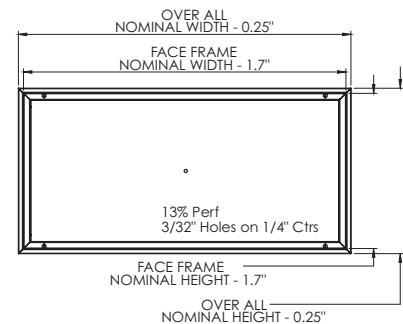
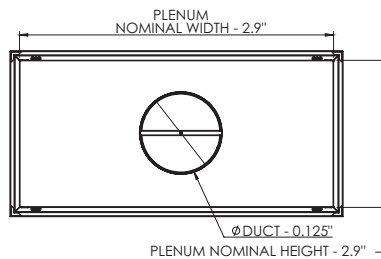
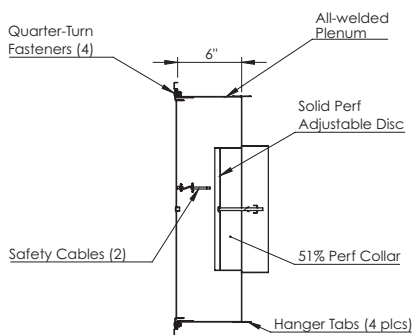

LAMINAR FLOW DIFFUSER

5300-HF

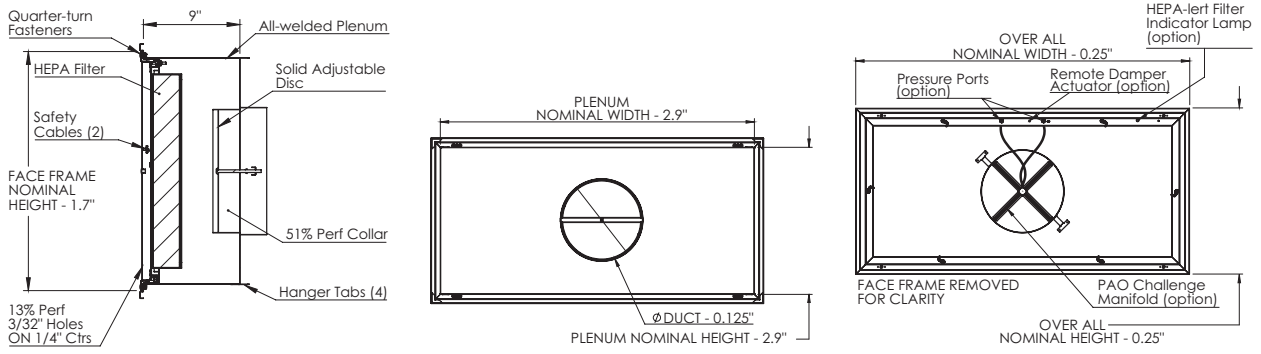

LAMINAR FLOW DIFFUSER

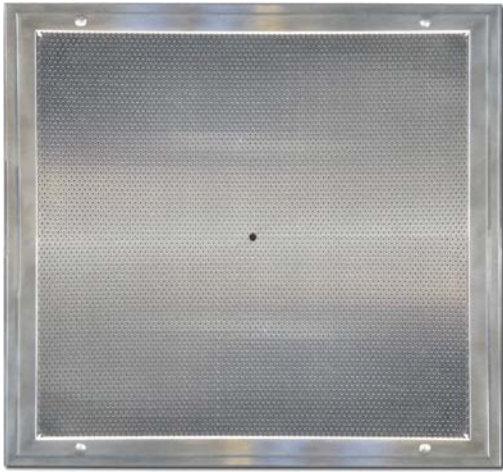

5350 Series Medium Capacity Laminar Flow Diffuser Panel

Standard Features:

- Type 304 stainless steel
- Medium capacity/airflow range design laminar flow diffuser
- Recommended velocity range 50-90 CFM/Sq. Ft.
- Perforated face design has 3/32" diameter holes on 3/16" staggered centers
- 23% Free Area
- Integral pressure plate ensures true laminar airflow
- Produces non aspirating, low velocity vertical air pattern; providing controlled downward projection of conditioned supply air
- Built-in screwdriver adjustable damper disk for even distribution and field balancing accessed by removing face plug
- Removable face plate allows for easy cleaning; secured by 1/4 turn fasteners
- Standard unit designed for both lay-in T-Bar ceiling systems and surface mount applications
- Integral earthquake hanger tabs
- #4 satin polished finish

Options:

- HEPA Rack with 9" plenum
MODEL: 5350-HF
- Type 316 Stainless
- Aluminum construction
- LED indicator light – illuminates when filter change is necessary
- Pressure ports
- Aerosol challenge manifold
- Powder coat finish

Inlet Options:

- Side Inlet
- End Inlet
- Rectangle Inlet
- Oval Inlet



5350

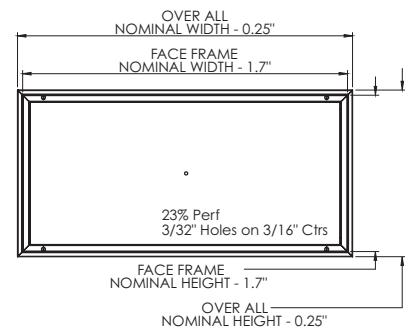
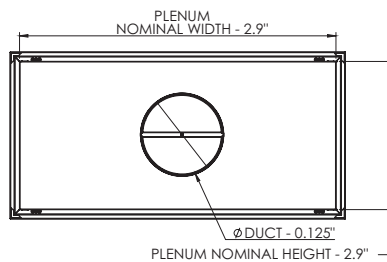
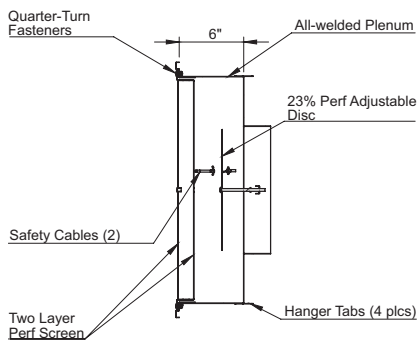

LAMINAR FLOW DIFFUSER

5350-HF

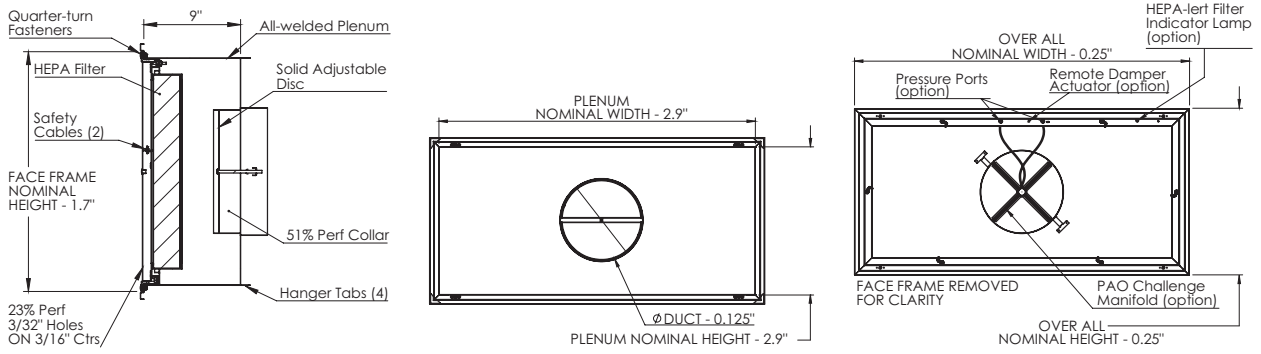

LAMINAR FLOW DIFFUSER

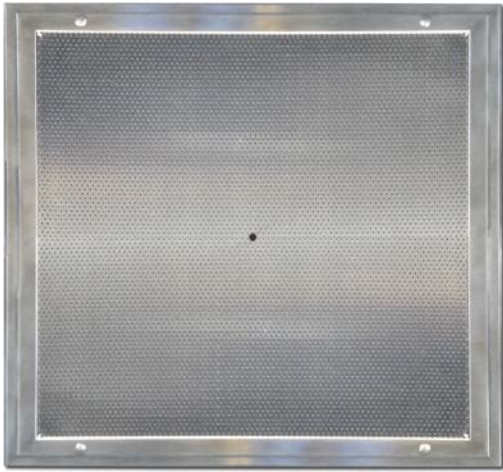

5375 Series High Capacity Laminar Flow Diffuser Panel

Standard Features:

- Type 304 stainless steel
- High capacity/airflow range design laminar flow diffuser
- Recommended velocity range 50-90 CFM/Sq. Ft.
- Perforated face design has 3/16" diameter holes on 5/16" staggered centers
- 33% Free Area
- Integral pressure plate ensures true laminar airflow
- Produces non aspirating, low velocity vertical air pattern; providing controlled downward projection of conditioned supply air
- Built-in screwdriver adjustable damper disk for even distribution and field balancing accessed by removing face plug
- Removable face plate allows for easy cleaning; secured by 1/4 turn fasteners
- Standard unit designed for both lay-in T-Bar ceiling systems and surface mount applications
- Integral earthquake hanger tabs
- #4 satin polished finish

Options:

- HEPA Rack with 9" plenum
MODEL: 5375-HF
- Type 316 Stainless
- Aluminum construction
- LED indicator light – illuminates when filter change is necessary
- Pressure ports
- Aerosol challenge manifold
- Powder coat finish

Inlet Options:

- Side Inlet
- End Inlet
- Rectangle Inlet
- Oval Inlet



5375

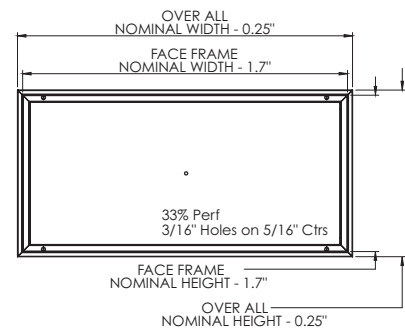
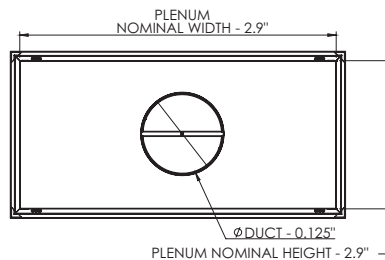
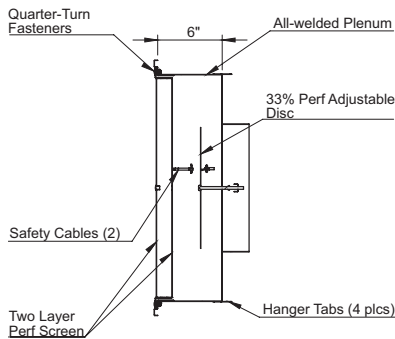

LAMINAR FLOW DIFFUSER

5375-HF

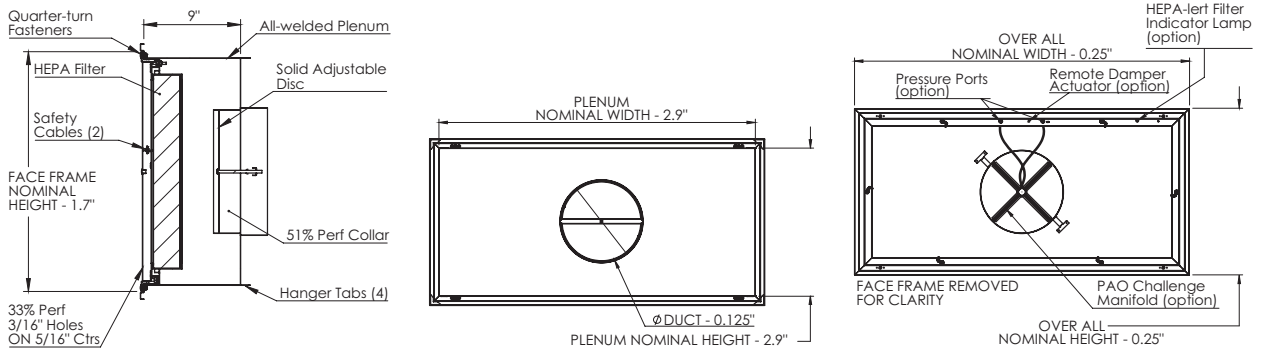

FAN POWERED LAMINAR FLOW DIFFUSER

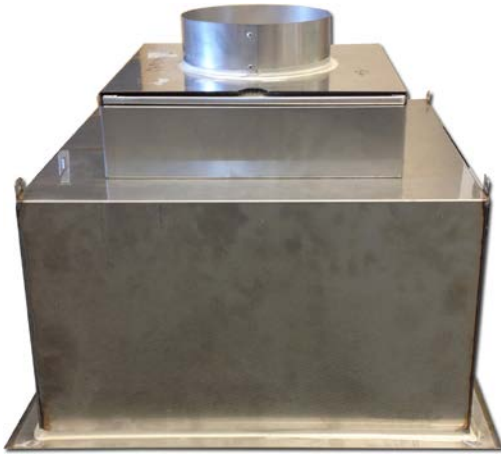

5700 Series Fan Powered Laminar Flow Diffuser with HEPA Filter

Standard Features:

- Type 304 stainless steel
- High capacity/airflow range design laminar flow diffuser
- Perforated face design has 3/16" diameter holes on 1/4" staggered centers
- 51% Free Area
- HEPA Filter
- Digital controlled ECM motor provides constant airflow for even air distribution and field balancing
- Digital controller displays airflow (CFM)
- Produces non aspirating, low velocity vertical air pattern; providing controlled downward projection of conditioned supply air
- 100% shut off damper eliminates considerable time and effort involved in changing filters
- Removable face plate allows for easy cleaning; secured by 1/4 turn fasteners
- Safety cables to prevent dropping of face
- Round inlets for simple duct connection
- Standard unit designed for both lay-in T-Bar ceiling systems and surface mount applications
- Integral earthquake hanger tabs
- #4 satin polished finish

Options:

- Type 316 Stainless
- Lighted diffuser
- Aluminum construction
- (1) Pressure Port
- (2) Pressure Port
- Aerosol challenge manifold
- LED indicator light – illuminates when filter change is necessary
- Powder coat finish

Inlet Options:

- Side Inlet
- End Inlet
- Rectangle Inlet
- Oval Inlet

Control Options:

- 0-10 VDC
- BAS/BMS
- LAN
- More – contact customer service



5700

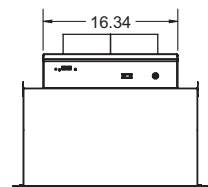
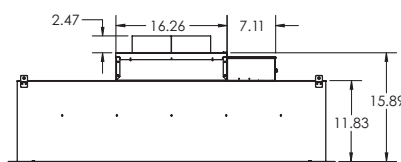
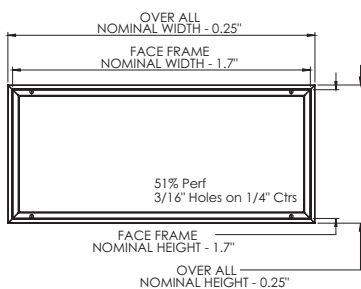

FLAT RADIAL PATTERN DIFFUSER



5160 Series Flat Radial Diffuser with 90° Air Flow Pattern

Standard Features:

- Type 304 stainless steel
- 90° radial air flow pattern
- Perforated face has 3/16" diameter holes on 1/4" staggered centers
- 51% free area
- Removable face plate; secured by 1/4 turn fasteners
- Safety cables to prevent dropping of face
- Round inlets for simple duct connection
- Standard unit designed for both lay-in T-Bar ceiling systems and surface mount applications
- Integral earthquake hanger tabs
- #4 satin polished finish

Options:

- HEPA Rack with 9" plenum
MODEL: 5160-HF
- 180° Radial flow pattern
MODEL: 5165
- 180° Radial flow pattern, HEPA Back with 9" plenum
MODEL: 5165-HF
- Type 316 Stainless
- Aluminum construction
- LED indicator light - Illuminates when filter change is necessary
- Pressure ports
- Aerosol challenge manifold
- Powder coat finish

Inlet Options:

- Side Inlet
- End Inlet
- Rectangle Inlet
- Oval Inlet



5160

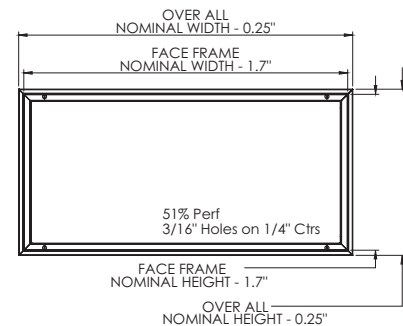
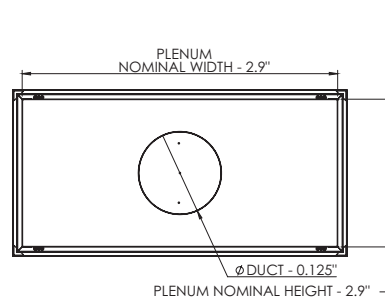
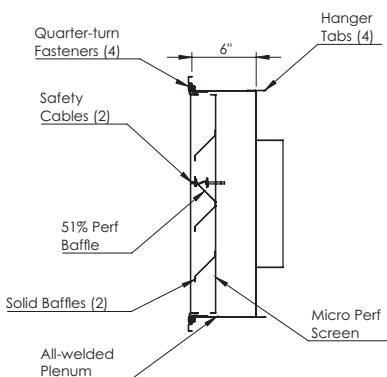

FLAT RADIAL PATTERN DIFFUSER

5160-HF

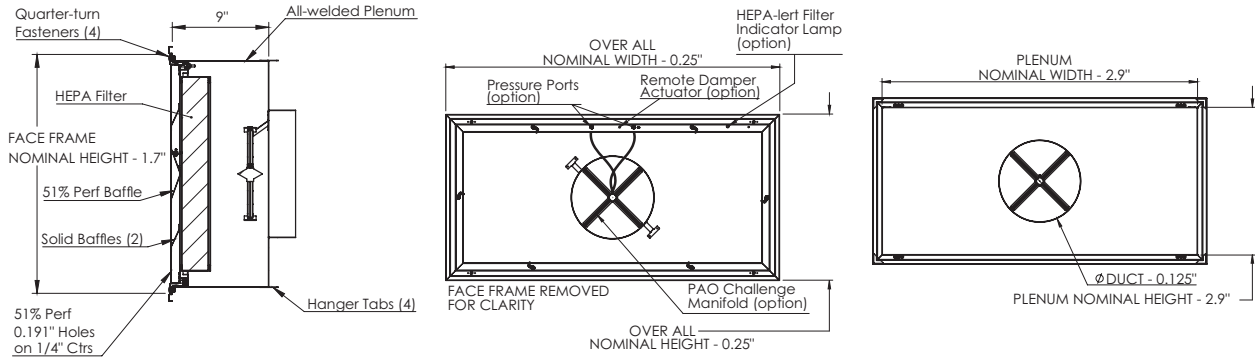

5165

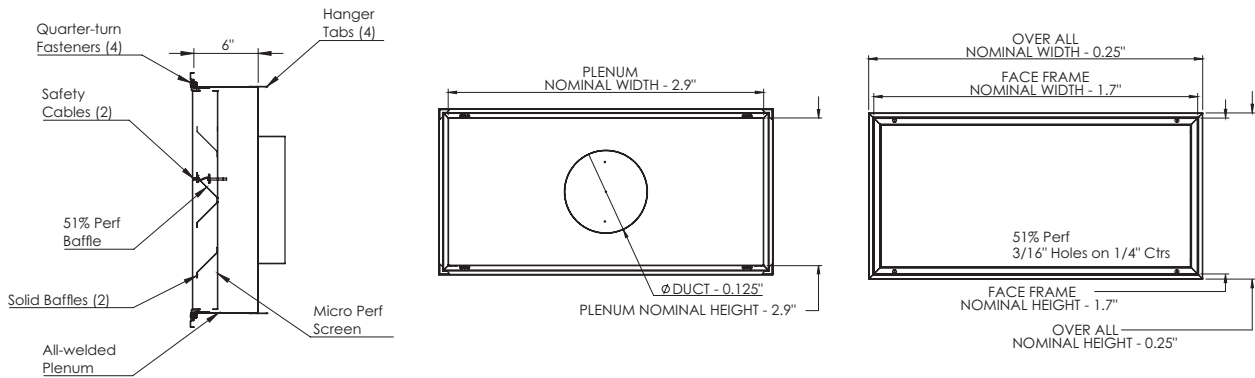

5165-HF

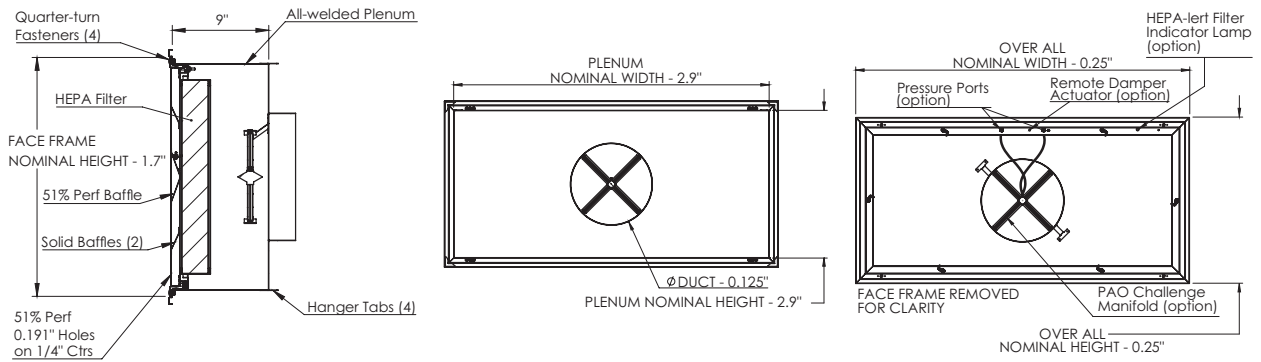

HINGED RADIAL DIFFUSER



5180 Series Hinged Radial Diffuser with 90° Air Flow

Standard Features:

- Type 304 stainless steel
- 90° Radial flow pattern for perimeter applications
- Curved perforated face design has 3/32" diameter holes on 1/4" staggered centers
- 13% Free Area
- Unique design of solid baffles in perforated face can handle large volumes of air with low initial face velocities and provide low aspiration and high ventilation rates
- Hinged perforated face allows easy access for cleaning; secured by 1/4 turn fasteners
- Standard unit designed for both lay-in T-Bar ceiling systems and surface mount applications
- Integral earthquake hanger tabs
- #4 satin polished finish

Options:

- HEPA Rack with 9" plenum
MODEL: 5180-HF
- 180° Radial flow pattern
MODEL: 5185
- 180° Radial flow pattern, HEPA Back with 9" plenum
MODEL: 5185-HF
- Type 316 Stainless
- Aluminum construction
- LED indicator light - Illuminates when filter change is necessary
- Pressure ports
- Aerosol challenge manifold
- Powder coat finish

Inlet Options:

- Side Inlet
- End Inlet
- Rectangle Inlet
- Oval Inlet



5180

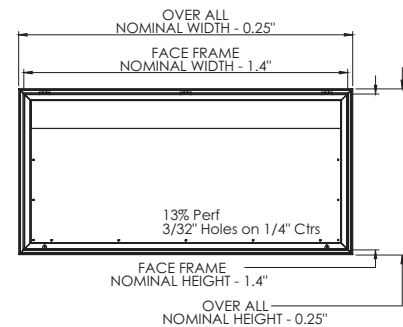
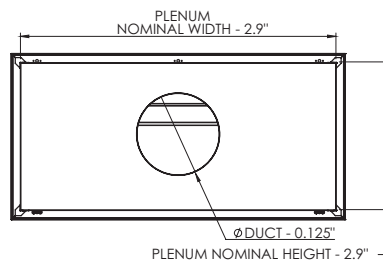
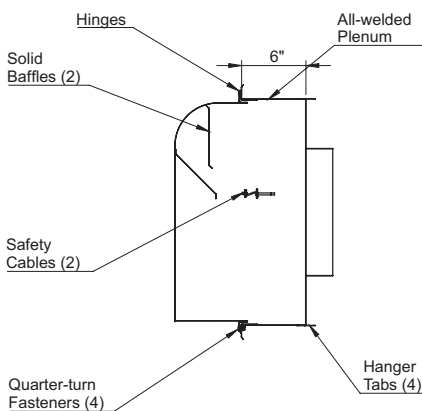

HINGED RADIAL DIFFUSER

5180-HF

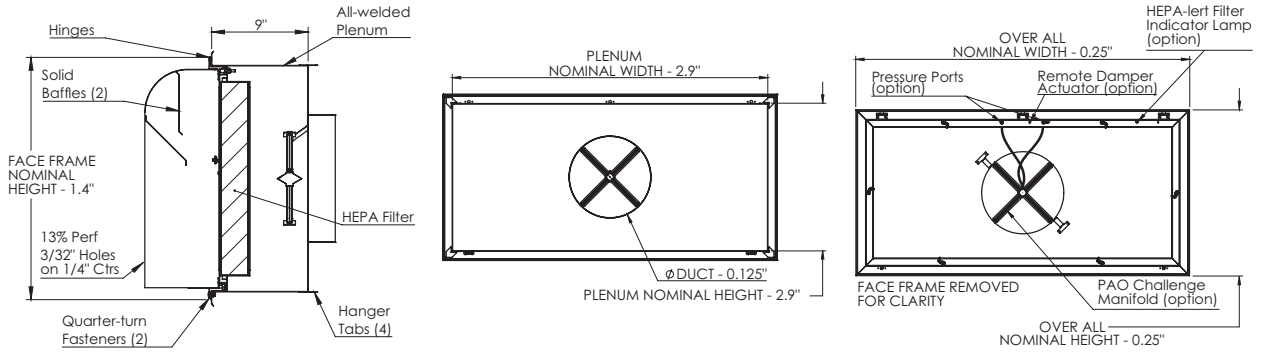

5185

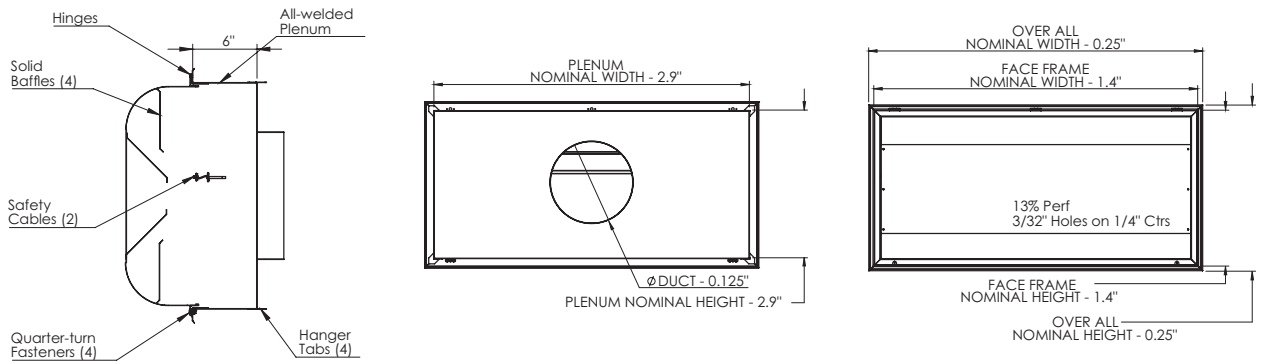

5185-HF

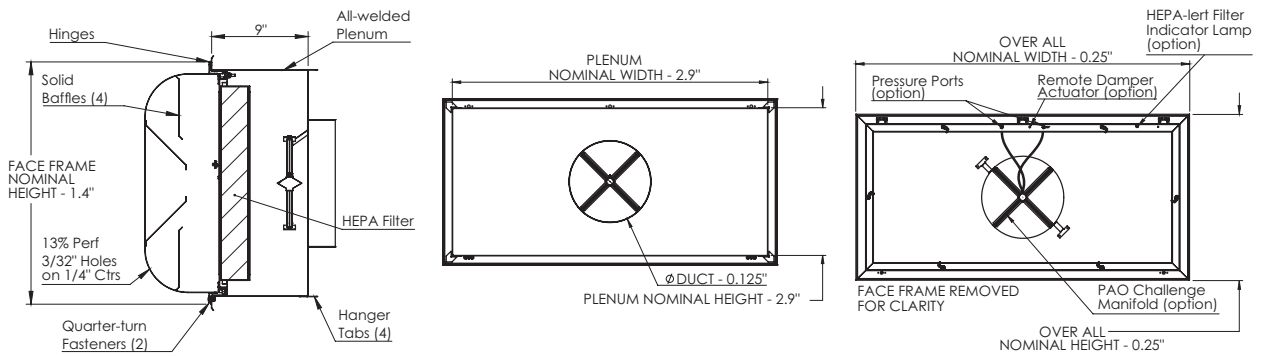

HEMISPHERICAL DIFFUSER



5500 Series Hemispherical Diffuser

Standard Features:

- Type 304 stainless steel
- Specially formed adjustable blades for maximum free area and directional throw
- High airflow capacity 200 – 1000 CFM
- Perforated center face has 3/32" diameter holes on 1/4" staggered centers
- 13% free area
- Individually adjustable air pattern controllers for delivering high volumes of low velocity air in radial pattern slightly below ceiling level
- Built-in screwdriver adjustable damper disk for even distribution and field balancing accessed by removing face plug
- Removable face plate; secured by 1/4 turn fasteners
- Safety cables to prevent dropping of face
- Round inlets for simple duct connection
- Standard unit designed for both lay-in T-Bar ceiling systems and surface mount applications
- Integral earthquake hanger tabs
- Minimum dimensions: 12" x 12"
- Maximum dimensions: 60" x 48"
- #4 satin polished finish

Options:

- HEPA Rack with 9" plenum
MODEL: 5500-HF
- Louvered center section
- Aluminum construction
- LED indicator light - Illuminates when filter change is necessary
- Pressure ports
- Aerosol challenge manifold
- Powder coat finish

Inlet Options:

- Side Inlet
- End Inlet
- Rectangle Inlet
- Oval Inlet



5500

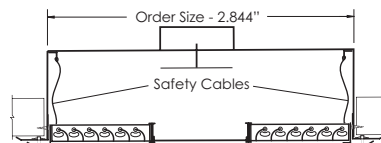
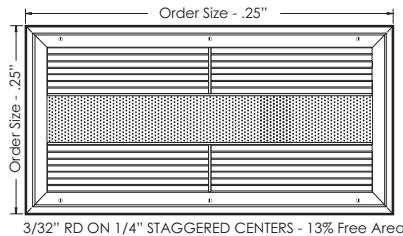

T-BAR LAY-IN DETAIL
1000 Plaster Frame with
1/4-Turn Fastener

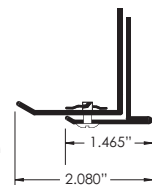

HEMISPHERICAL DIFFUSER

5500-HF

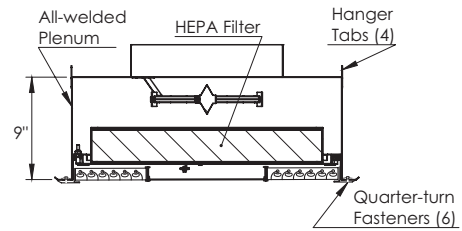
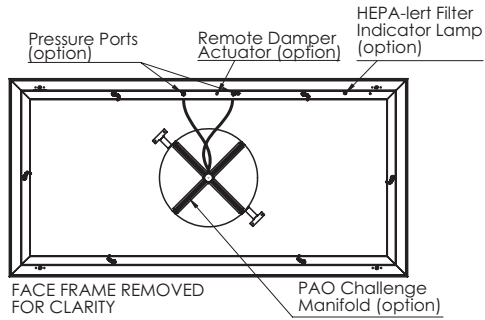
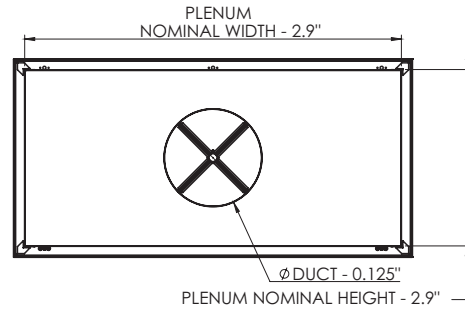
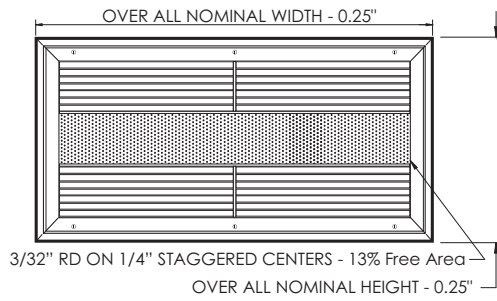

PERIMETER SLOT DIFFUSER



5600 Series Sterile Room Perimeter Slot Diffuser

Standard Features:

- Type 304 stainless steel
- Unique double slot design creates continuous curtain of air, angled outwards 5° - 15°
- Perforated face design has 3/32" diameter holes on 1/4" staggered centers
- 13% Free Area
- Longitudinal deflectors that horizontally deflect a small amount of air lengthwise joining sections and corners for a truly continuous air curtain
- Integral pressure plate ensures true laminar airflow
- Removable face plate allows for easy cleaning; secured by 1/4 turn fasteners
- Safety cables to prevent dropping of face
- Flanged inlets for simple duct connection
- Standard unit designed for both lay-in T-Bar ceiling systems and surface mount applications
- Integral earthquake hanger tabs
- #4 satin polished finish

Options:

- Type 316 Stainless
- Aluminum construction

Inlet Options:

- Side Inlet
- End Inlet
- Rectangle Inlet
- Oval Inlet

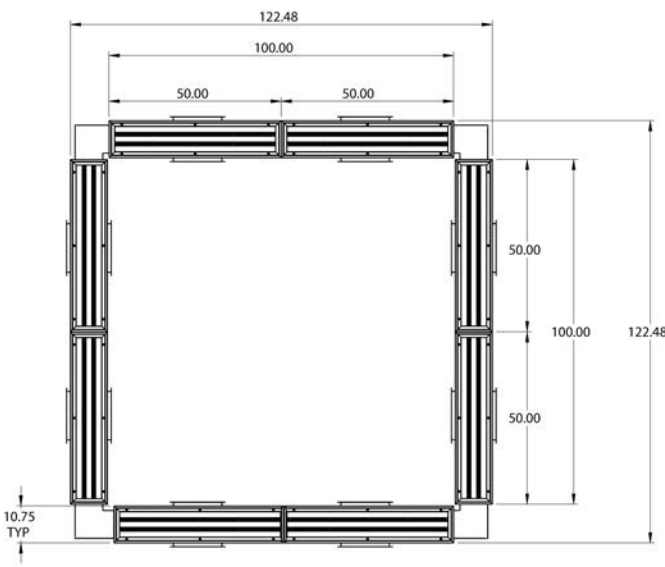
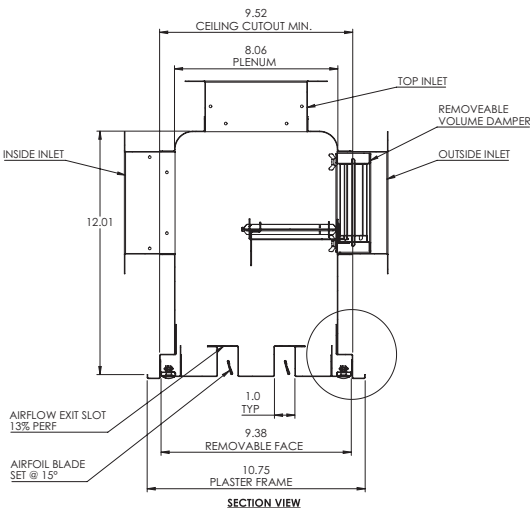

ROOM-SIDE VIEW

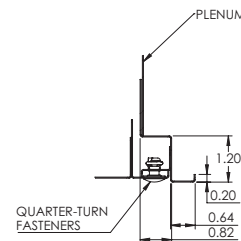

FRAME DETAIL



PERIMETER SLOT DIFFUSER

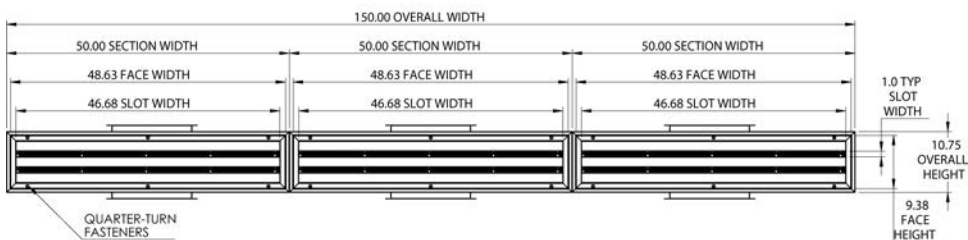
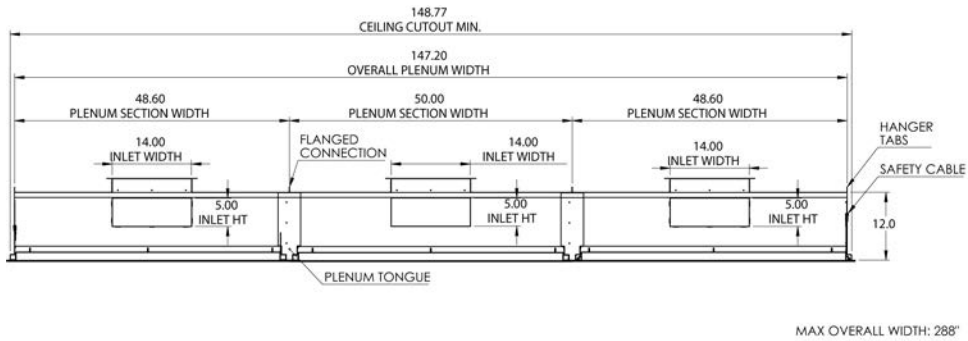
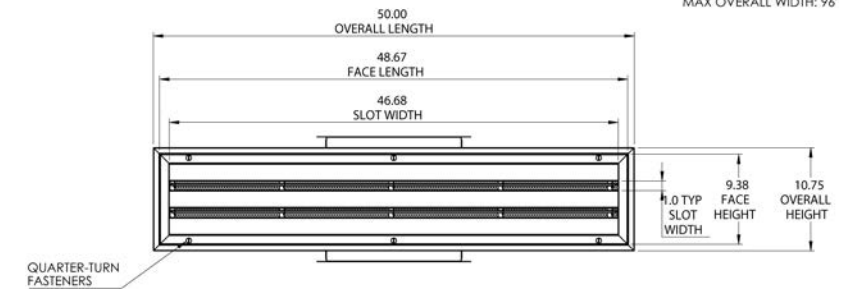
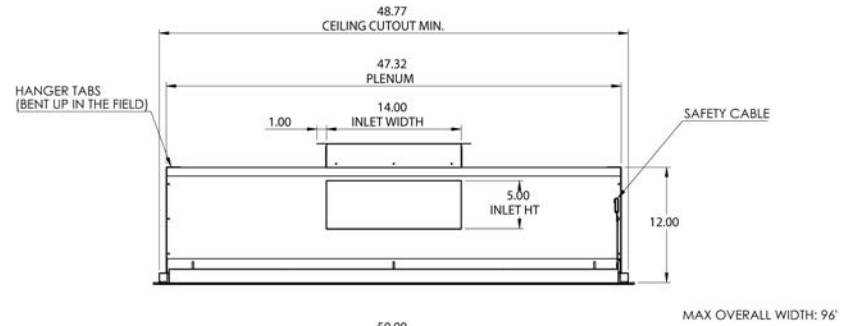
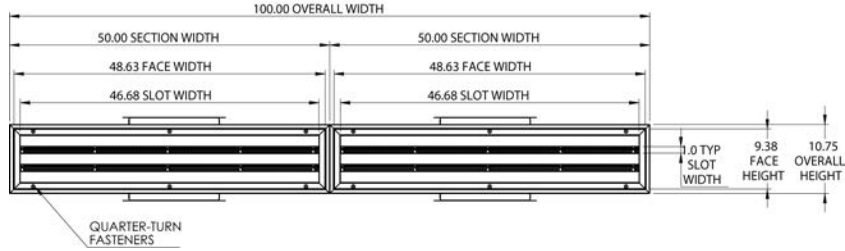
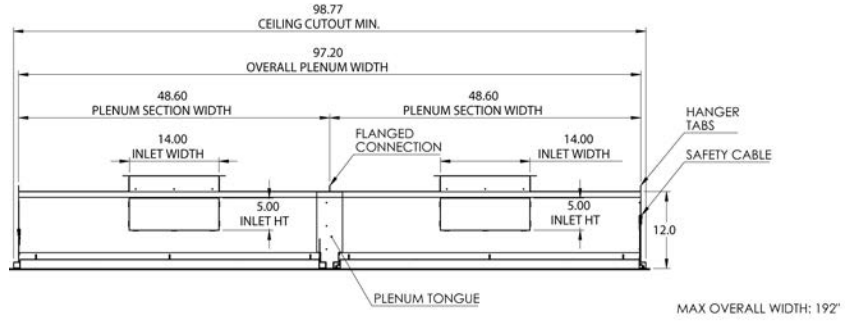

HEPA/ULPA FILTERS



HF Series HEPA Filter

Standard Features:

- HEPA filter 99.99% minimum removal efficiency on 0.3 micrometer particle size
- Anodized aluminum Gel Seal frame provides a leak-tight connection
- Separatorless 2" deep media pack standard
- Test port integral with every filter; used to measure filter pressure drop, perform leakage (scan) tests or to adjust balancing dampers in the diffuser neck
- UL 900 Class 1 Listed and Factory Mutual Approved
- Individually scan tested per Section 6.2 of IEST-RP-CC034.1
- Packaged independently from the diffuser for final installation of the filter in the field (by others)

Options:

- ULPA Filter 99.995% minimum removal efficiency on 0.12 micrometer particle size

MODEL: UF

- 4" media pack



HF/UF

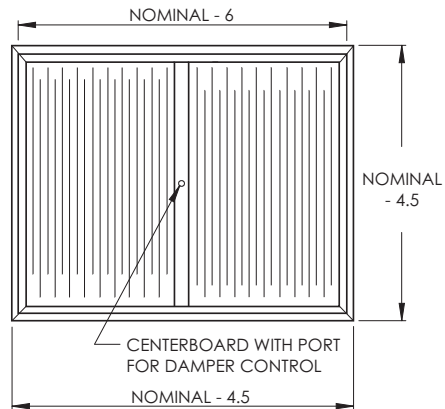
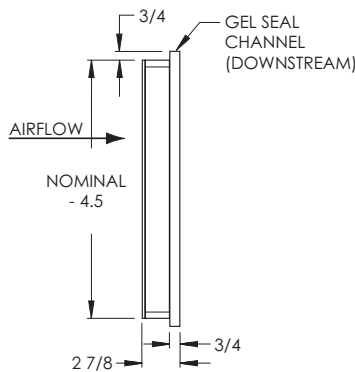

DIFFUSER KNIFE EDGE DIMENSIONS = NOMINAL - 5 3/8



MODULAR CORE DIFFUSER

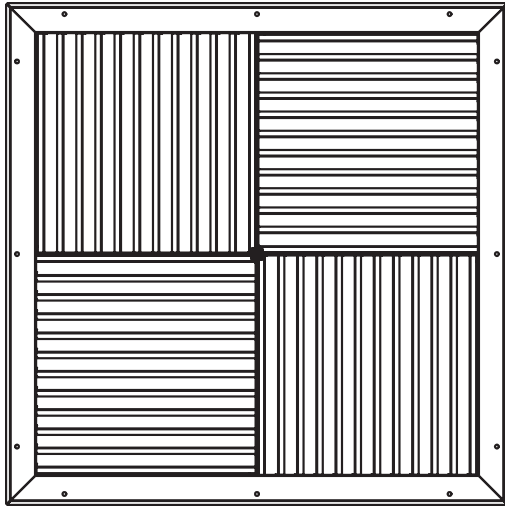

MA-SS Series Surface Mount Fixed Pattern Ceiling Diffuser

Standard Features:

- Type 304 stainless steel
- Fixed louvered air pattern
- Five air patterns available
- Countersunk mounting holes for flush appearance with stainless sheet metal screws
- Satin polished finish

Options:

- Type 316 stainless steel
- Opposed blade damper
- Square to round transition collar
- T-Bar application
- Tamper proof screws – stainless steel Torx Center Pin
- Powder coat finish

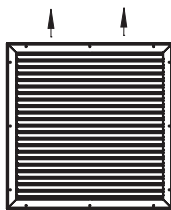
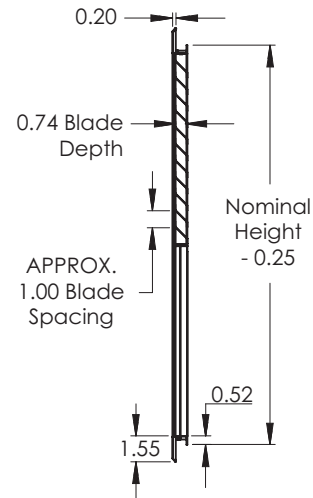
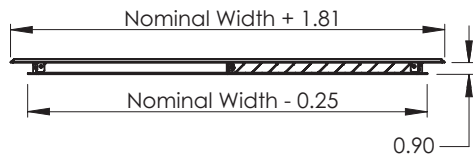

1-WAY

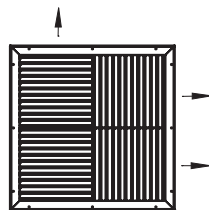

2-WAY CORNER

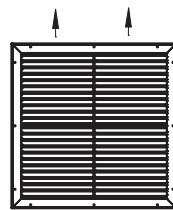

2-WAY OPPOSITE

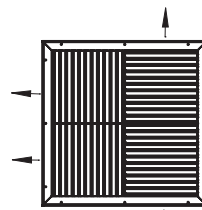

3-WAY

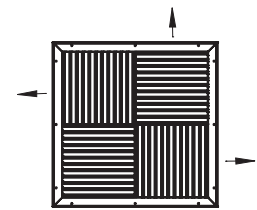

4-WAY

ADJUSTABLE BLADE DIFFUSER

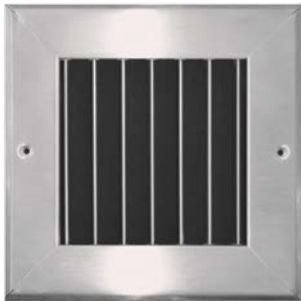
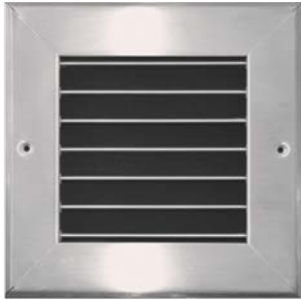

931-SS Series Single Deflection Diffuser

Standard Features:

- Type 304 stainless steel
- Adjustable single deflection diffuser
- Airfoil blades individually adjustable on 3/4" centers, parallel to longest dimension given
- Countersunk mounting holes for flush appearance with stainless sheet metal screws
- Minimum size 4" x 4"
- Maximum size 48" x 48"
- Satin polished finish

Options:

- Blades parallel to shortest dimension
- **MODEL: 932-SS**
- Type 316 stainless steel
- Opposed blade damper
- Available blade centers at 1/2", 1", & 1 1/2"
- Long throw individually adjustable blades with 1 1/2" blades on 1 1/2" centers or 3" blades on 3" centers
- Tamper proof screws – stainless steel Torx Center Pin
- Square to round transition
- Powder coat finish



931-SS

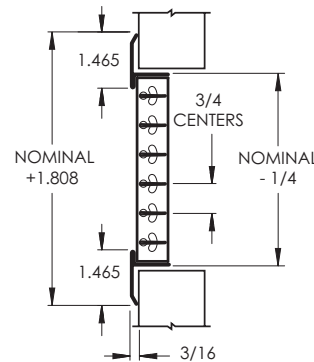
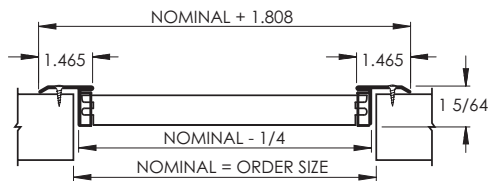

932-SS

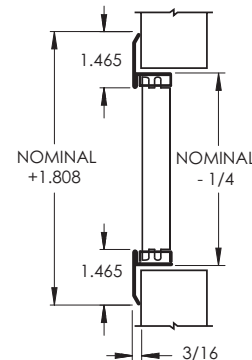
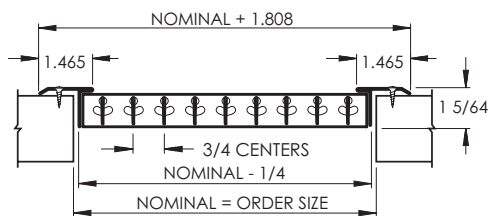

ADJUSTABLE BLADE DIFFUSER



933-SS Series Double Deflection Diffuser

Standard Features:

- Type 304 stainless steel
- Adjustable double deflection diffuser
- Airfoil blades individually adjustable on 3/4" centers
- Front blades are parallel to longest dimension
- Back blades are parallel to shortest dimension
- Countersunk mounting holes for flush appearance with stainless sheet metal screws
- Minimum size 4" x 4"
- Maximum size 48" x 48"
- Satin polished finish

Options:

- Front blades parallel to shortest dimension, black blades parallel to longest dimension

MODEL: 934-SS

- Type 316 stainless steel
- Opposed blade damper
- Available blade centers at 1 1/2"
- Heavy duty construction – fixed front blades on 1/2" centers with adjustable back blades on 3/4" centers
- Long throw – individually adjustable blades with 1 1/2" blades on 1 1/2" centers or 3" blades on 3" centers
- Tamper proof screws – stainless steel Torx Center
- Square to round transition
- Powder coat finish



933-SS

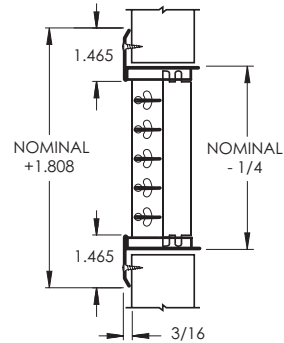
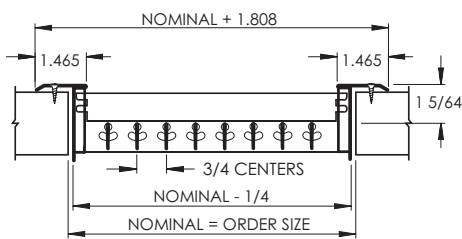

934-SS

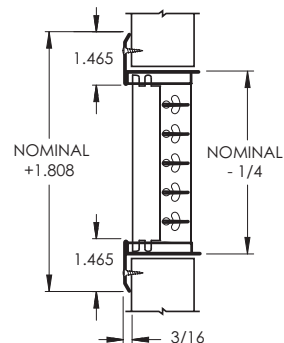
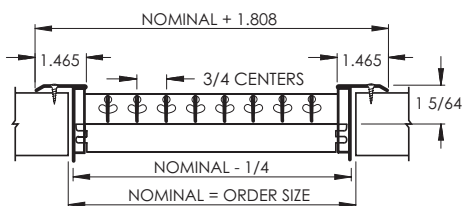

FIXED BLADE RETURN



935-SS



936-SS



937-SS



938-SS

935-SS Series 45° Fixed Airfoil Blade Return Air Grille

Standard Features:

- Type 304 stainless steel
- Fixed airfoil blades at 45° are parallel to longest dimension
- Blades are set on 3/4" centers
- Countersunk mounting holes for flush appearance with stainless sheet metal screws
- Minimum size 4" x 4"
- Maximum size 60" x 48"
- Satin polished finish

Options:

- Blades set at 45° parallel to shortest dimension
MODEL: 936-SS
- Blades set at 0° parallel to shortest dimension
MODEL: 937-SS
- Blades set at 0° parallel to shortest dimension
MODEL: 938-SS
- Type 316 stainless steel
- Opposed blade damper
- Blades set at 1/2" centers
- Heavy duty construction
- Tamper proof screws – stainless steel Torx Center Pin
- Square to round transition
- Powder coat finish



935-SS

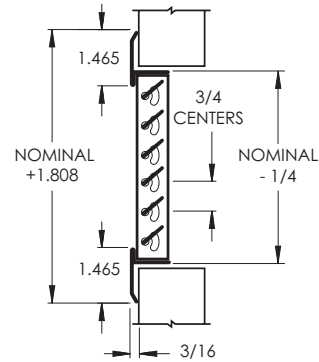
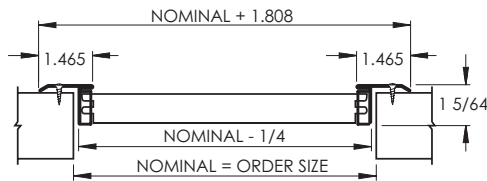

936-SS

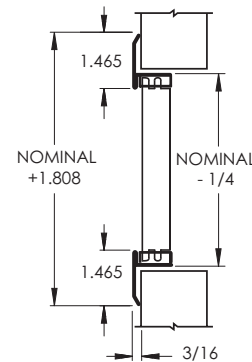
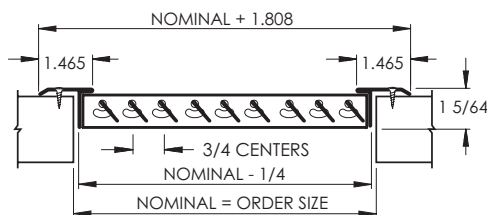

FIXED BLADE RETURN

937-SS

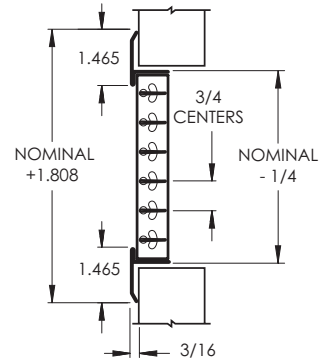
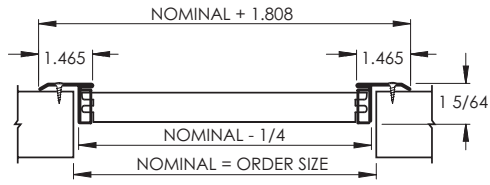

938-SS

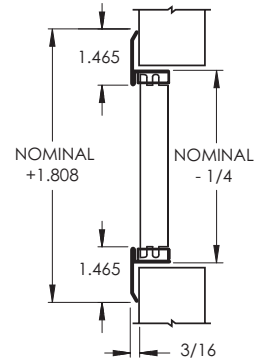
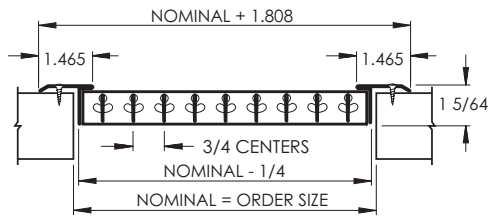

DOOR GRILLE

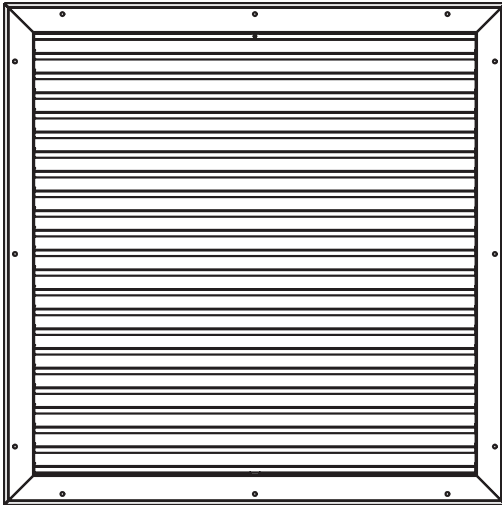

4100-SS Series Louvered Door Grille with Auxiliary Frame

Standard Features:

- Type 304 stainless steel
- Fixed louvered blades parallel to the 1st dimension given
- Designed to transfer air with limited vision into wood or hollow doors
- Loose frame to complete finished look on both sides of door
- Countersunk mounting holes for flush appearance with stainless sheet metal screws
- Satin polished

Options:

- Type 316 Stainless
- Tamper proof screws – stainless steel Torx Center Pin
- Powder coat finish

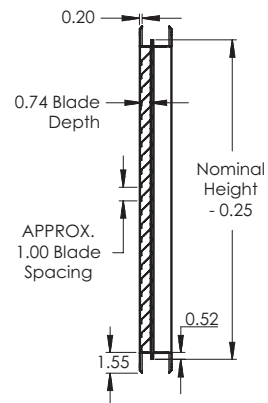
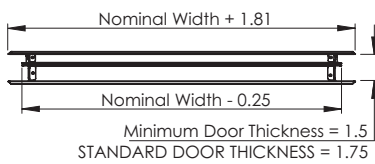

LOUVERED RETURN

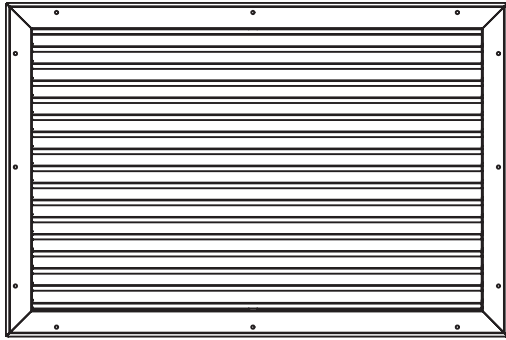

915-SS Series 45° Fixed Louvered Blade Return Air Grille

Standard Features:

- Type 304 stainless steel
- Fixed 45° louvered blades parallel to longest dimension
- Approximately 60% free area
- Designed for limited vision through grille
- Louvered blades are reinforced from rear on approximately 12" centers
- Countersunk mounting holes for flush appearance with stainless sheet metal screws
- Minimum size 4" x 4"
- Maximum size 60" x 48"
- Satin polished finish

Options:

- Blades parallel to shortest dimension
- MODEL: 916-SS**
- Type 316 stainless steel
 - Opposed blade damper
 - Square to round transition collar
 - T-Bar application
 - Tamper proof screws – stainless steel Torx Center Pin
 - Powder coat finish

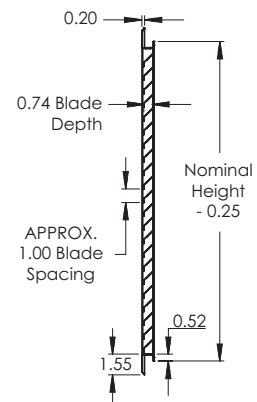
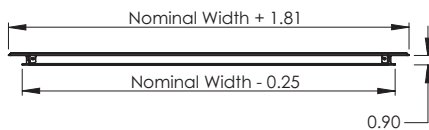

PERFORATED RETURN

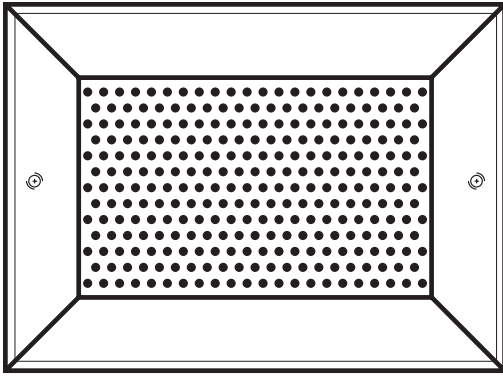

600P-SS Series Perforated Return Air Grille

Standard Features:

- Type 304 stainless steel
- Perforated face return air grille
- 3/16" holes on 1/4" staggered centers
- 51% free area
- Countersunk mounting holes for flush appearance with stainless sheet metal screws
- Minimum size 4" x 4"
- Maximum size 60" x 48"
- Satin polished finish

Options:

- Type 316 stainless steel
- Opposed blade damper
- Square to round transition collar
- T-Bar application
- Tamper proof screws – stainless steel Torx Center Pin
- Powder coat finish

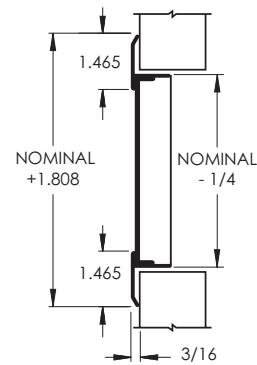
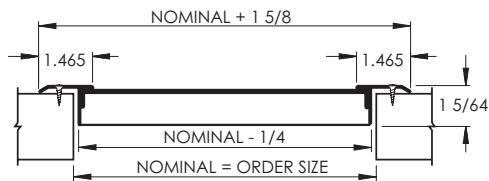

LATTICE RETURN



600-SS Series Eggcrate Return Air Grille

Standard Features:

- Type 304 stainless steel
- 1/2" × 1/2" × 1/2" pattern
- 90% free area
- Countersunk mounting holes for flush appearance with stainless sheet metal screws
- Minimum size 4" × 4"
- Maximum size 48" × 48"
- Satin polished finish

Options:

- Type 316 stainless steel
- Opposed blade damper
- Square to round transition collar
- T-Bar application
- 1" × 1" × 1" pattern
- Core only
- Tamper proof screws – stainless steel Torx Center Pin
- Channel frame
- Powder coat finish

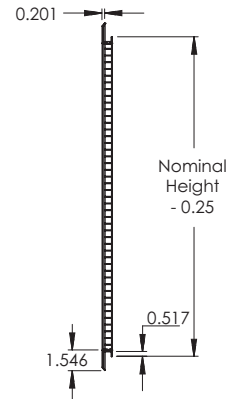
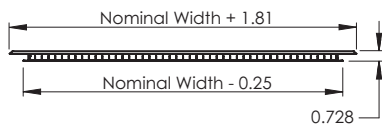

FILTERED RETURN

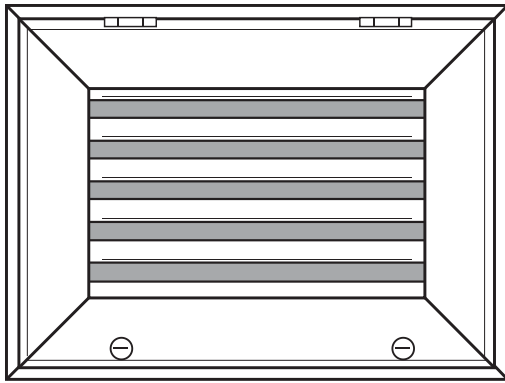

935FG-SS Series Fixed 45° Airfoil Blade Hinged 1" Filter Grille

Standard Features:

- Type 304 stainless steel
- Fixed airfoil blades at 45° are parallel to longest dimension
- Blades are set on 3/4" centers
- Hinged face with hinges parallel to longest side
- Holds up to a 1" filter (not included)
- Satin polished finish

Options:

- 2" Filter capacity
- T-Bar application
- Perforated face
- Type 316 stainless steel
- Short blades
- Alternative hinge options available
- Opposed blade damper
- Square to round transition
- 1/2" centers
- Powder coat finish

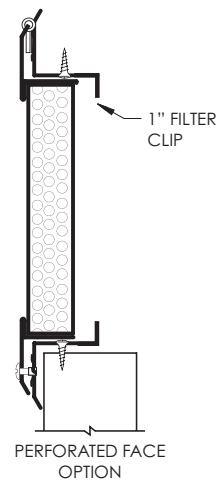
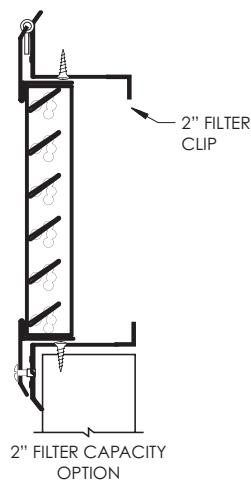
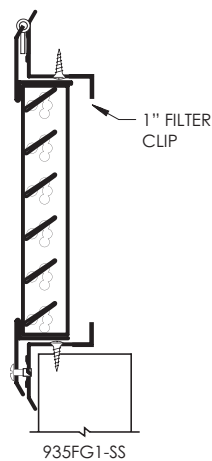
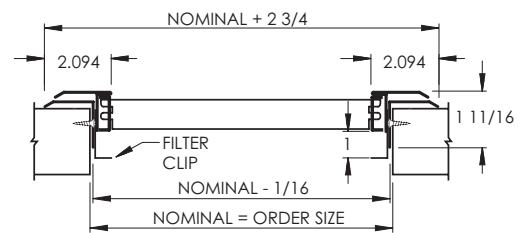
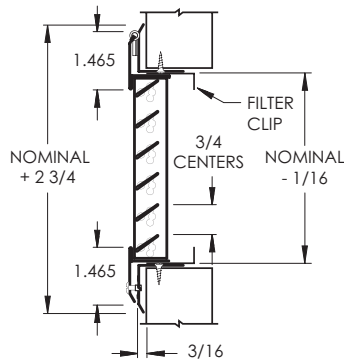

LOUVERED T-BAR DIFFUSER

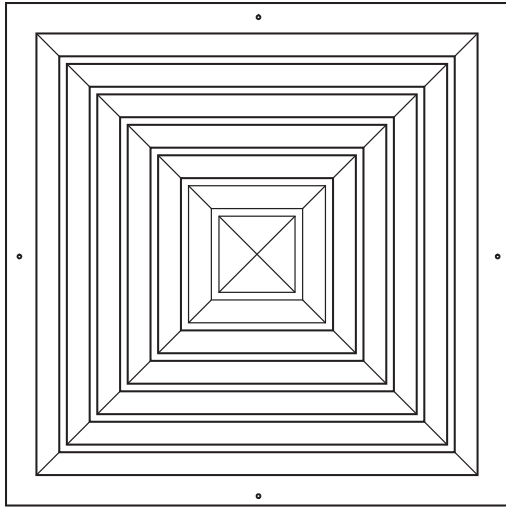

DVD-SS Series Surface Mount Louvered Ceiling Diffuser

Standard Features:

- Type 304 stainless steel
- Fixed louvered air pattern with non-removable core
- Five air patterns available
- Countersunk mounting holes for flush appearance with stainless sheet metal screws
- Minimum size 4" x 4"
- Maximum size 48" x 24"
- Satin polished finish

Options:

- Type 316 stainless steel
- Square to round transition collar
- T-Bar application
- Mixing vanes
- Stainless steel hinge on 4 sides for adjustable throws
- Fractional, exact I.D. and O.D. dimensions
- Tamper proof screws – stainless steel Torx Center Pin
- Powder coat finish

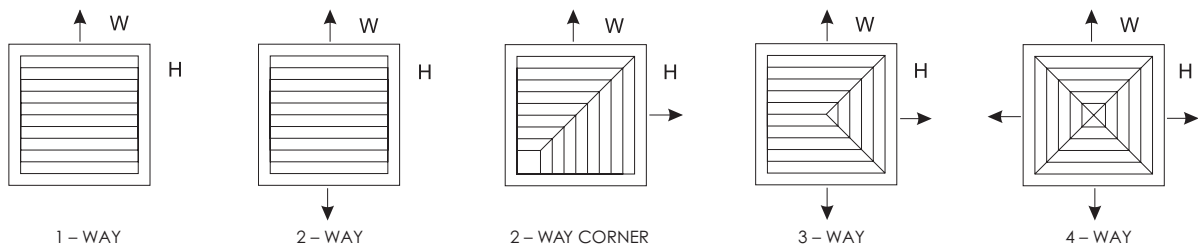
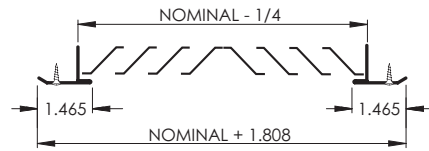

LOUVERED T-BAR DIFFUSER

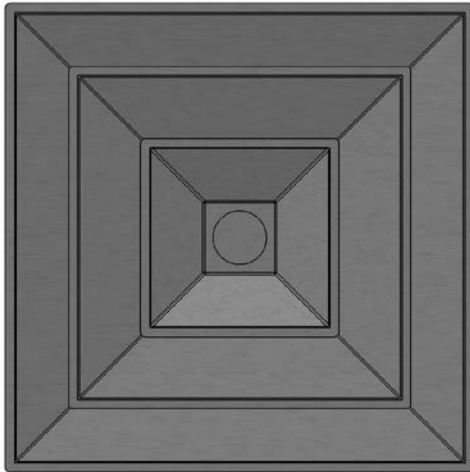

HVD-SS Series Adjustable 4-Cone T-Bar Diffuser

Standard Features:

- Type 304 stainless steel
- 4 Cone design T-Bar diffuser
- Die stamped cones
- Designed for high volume air delivery
- 360° air diffusion
- Removable core for easy duct access
- 2 × 2 stainless steel panel
- Square to round No Labor Collar
- Collar sizes available in 4", 5", 6", 8", 10", 12", 14", & 15"
- Satin polished finish

Options:

- Type 316 stainless steel
- Aluminum construction
- 9/16" Narrow slot frame
- Surface mount
- Volume control damper
- Center hole with plug for damper access
- Powder coat finish

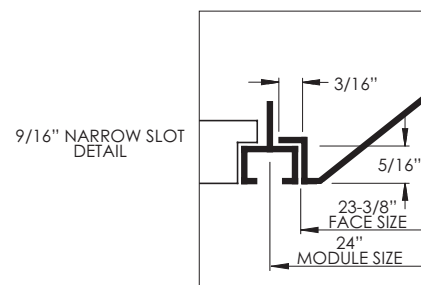
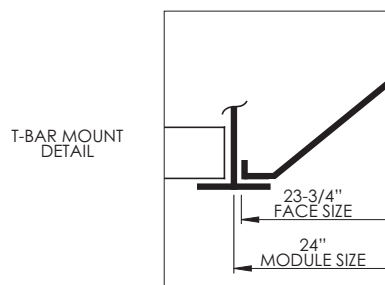
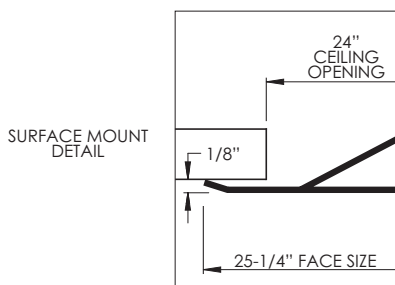
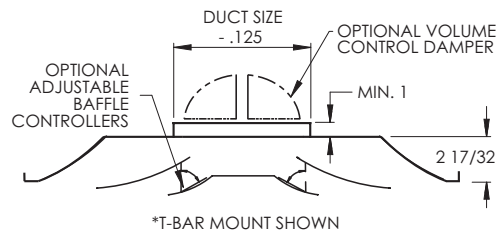

LOUVERED T-BAR DIFFUSER

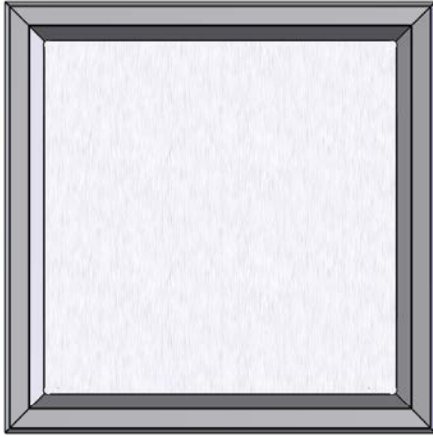

HL-SS Series Architectural T-Bar Plaque Diffuser

Standard Features:

- Type 304 stainless steel
- Single plaque T-Bar diffuser
- Designed for high volume air delivery
- 360° air diffusion
- Removable core for easy duct access
- 2 × 2 stainless steel panel
- Square to round No Labor Collar
- Collar sizes available in 4", 5", 6", 8", 10", 12", 14", & 15"
- Satin polished finish

Options:

- Type 316 stainless steel
- Aluminum construction
- 9/16" Narrow slot frame
- Surface mount
- Volume control damper
- Powder coat finish

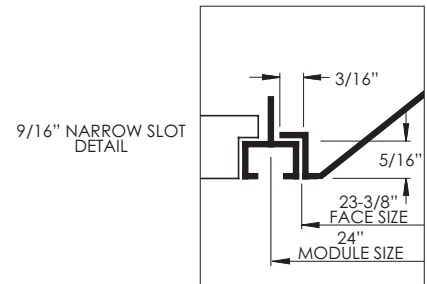
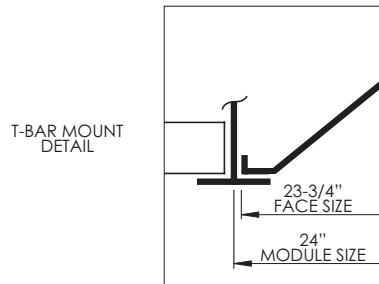
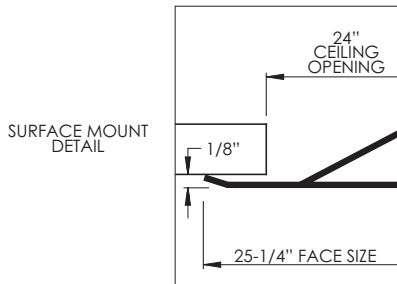
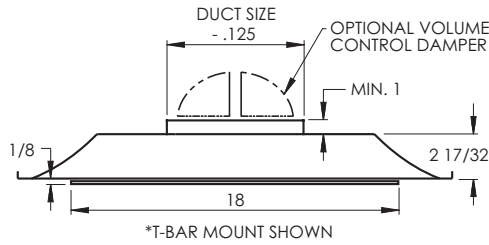

PERFORATED T-BAR DIFFUSER

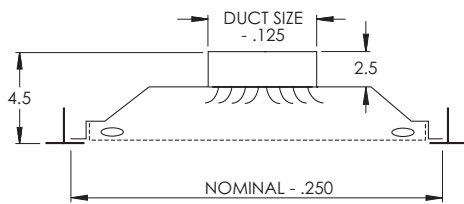
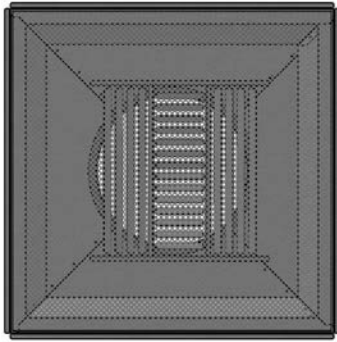

825CB-SS Series Perforated Adjustable Curved Blade T-Bar Diffuser

Standard Features:

- Type 304 stainless steel
- Adjustable curved blades
- Perforated removable face
- 3/16" holes on 1/4" staggered centers
- 51% free area
- Available in 1, 2, 3, or 4-way patterns
- 2 × 2 stainless steel panel
- Square to round transition collar
- Satin polished finish

Options:

- Type 316 stainless steel
- Aluminum construction
- Opposed blade damper
- Adjustable pattern controllers
- 1 × 1 T-Bar
- Butterfly damper
- Radial damper
- Powder coat finish



PERFORATED T-BAR RETURN

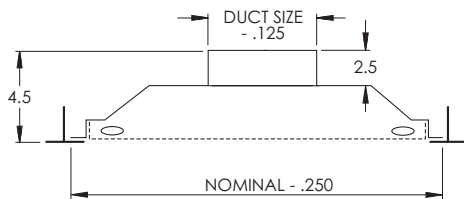
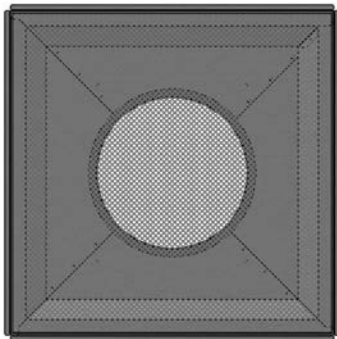

830-SS Series Perforated Adjustable Curved Blade T-Bar Diffuser

Standard Features:

- Type 304 stainless steel
- Perforated removable face
- 3/16" holes on 1/4" staggered centers
- 51% free area
- 2 × 2 stainless steel panel
- Square to round transition collar
- Satin polished finish

Options:

- Type 316 stainless steel
- Aluminum construction
- Opposed blade damper
- 1 × 1 T-Bar
- Butterfly damper
- Radial damper
- Powder coat finish



LINEAR GRILLES AND DIFFUSERS



Linear-SS Series Linear Bar Grille

Standard Features:

- Type 304 stainless steel
- Designed for several applications
- 3/8" or 1/2" spacing with 0° or 15° deflection
- 1/8" or 1/4" thick core blades run parallel to longest dimension
- Standard flange frame width 1"
- Satin polished finish

Options:

- Type 316 stainless steel
- Aluminum construction
- Opposed Blade Damper
- Concealed mounting tabs
- Countersunk mounting holes for flush appearance with stainless sheet metal screws (Flanged Frame only)
- Floor Grille (6" back supports)
- Wall Grille (12" back supports)

Frame Type:

- Flange
- Straight

Blade options:

- 1/8" bars on 3/8" centers
- 1/8" bars on 1/2" centers
- 1/4" bars on 1/2" centers

Blade deflection:

- 0°
- 15°



FLANGE FRAME

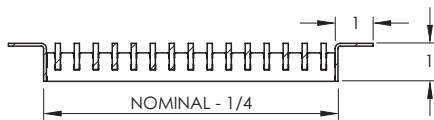
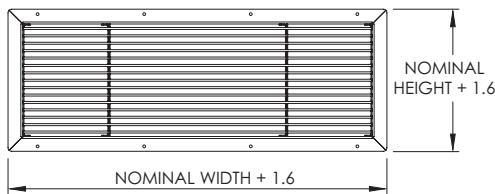

STRAIGHT FRAME

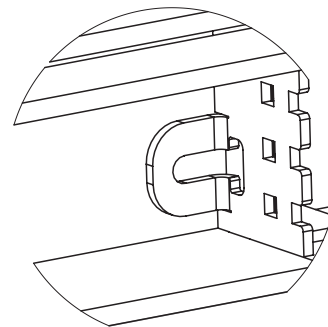
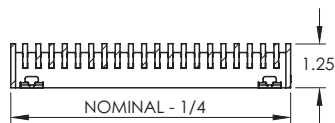
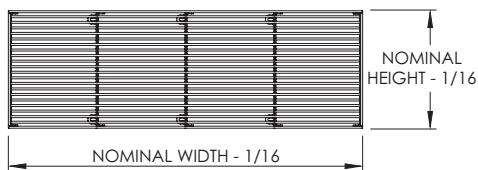

CONCEALED MOUNTING TAB DETAIL
(BARS REMOVED FOR CLARITY)

LINEAR SLOT DIFFUSERS



LSD-SS Series Linear Slot Diffuser

Standard Features:

- Type 304 Stainless
- 1" fixed center T's
- Available in multiple lengths
- Air pattern deflector
- Felt wiper air seal
- Satin polished finish

Options:

- Available in 3/4" or 1" slot widths
- Available in 1 slot up to 18 slots
- Type 316 Stainless
- 1 1/2" blade centers
- Internal insulation on all four sides
- Inlet Damper
- Galvanized steel plenum
- Stainless steel plenum
- Baked Epoxy-Polyester hybrid powder coat finish

Mount:

- Surface Mount
- T-Bar Mount

T Options:

- One side T furnished
- Both side T's furnished
- One pair of TC clips furnished

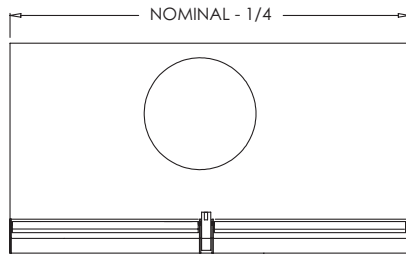

LSD-SS

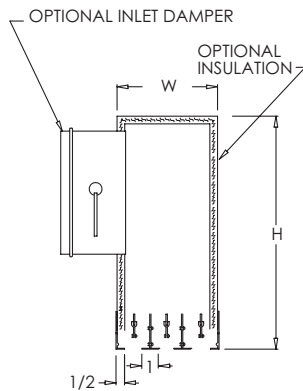

Mounting Options

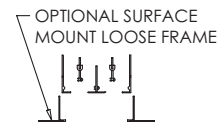
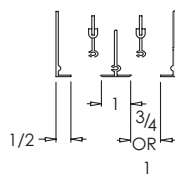

T Options



Standard: 2 Center T's
(No side T's or TC Clips)



1 Side T Furnished



Both Side T'S Furnished



1 Pair of TC Clips Furnished



SPIRAL DIFFUSERS AND REGISTERS

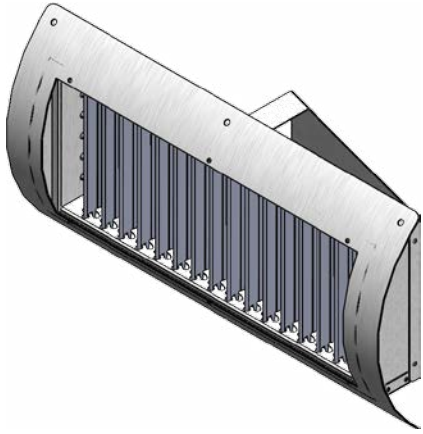

RS-SS Series Stainless Steel Radius Spiral Diffuser

Standard Features:

- Type 304 stainless
- Radius spiral mount diffuser
- Curved radius fits flush to spiral pipe
- Single deflection diffuser, horizontal or vertical blades
- 3/4" blade spacing
- Blades are parallel to the shortest dimension
- Allows for 2-way airflow adjustment
- Minimum size 4" x 4"
- Satin polished finish

Options:

- Stainless Steel Transition box style spiral diffuser

MODEL: SD-SS

- Type 316 Stainless
- Opposed Blade Damper
- Horizontal blades
- Vertical blades

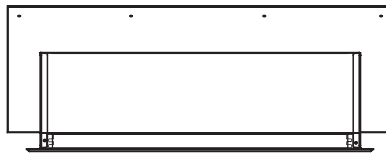
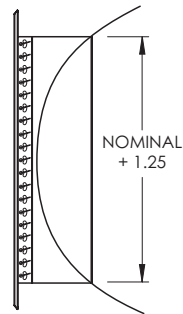
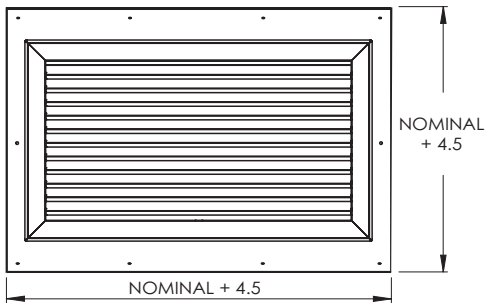

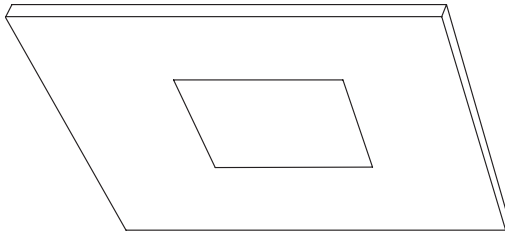

700-SS Series T-Bar Panel Only

Standard Features:

- Type 304 stainless steel
- Square hole opening
- Designed to accommodate most stainless steel products
- Satin polished finish

Options:

- Type 316 stainless steel

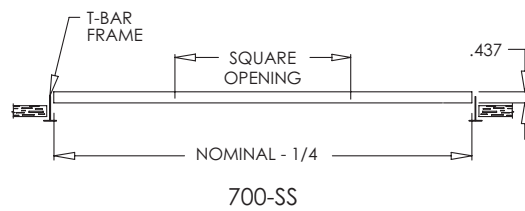

DESIGN TIPS

Placing units which throw directly toward each other.

Grilles of equal capacities should be sized for throw equal to 1/2 the distance between them.

High ceiling or wall placement and getting air down to the occupied zone.

Select and place units so they can discharge directly toward each other and the air streams meet at speeds greater than 50 fpm. The air streams will converge and proceed downward. The horizontal plus vertical distance traveled will equal the cataloged throw.

Figuring throw to a wall.

Units discharging toward a wall should be sized to throw to a 50 fpm terminal velocity at the opposite wall.

Lengthening the throw by taking advantage of the Coanda effect.

Ceiling diffusers use the Coanda effect to attain their throws and this effect can be used as well with high sidewall mounted supply grilles. Placing the grille within 1 foot of the ceiling will allow upward adjustment of horizontal front blades to extend the cataloged throws. To obtain the new throw at the specified terminal velocity, multiply the cataloged throw values by 1.414 to arrive at throws that take advantage of the Coanda effect.

COLD AIR CORRECTIONS

Although the industry norm for performance data is under isothermal conditions (ASHRAE Standard 70-1991), where the primary air (the air being introduced into the room) is the same temperature as the room air, a significant percentage of operating conditions involve cooler primary air entraining warmer room air. Cooler primary air is less buoyant and will reduce the throw, resulting in throw values that are significantly shorter than the cataloged performance data. To obtain throw values when the primary air is 20° cooler than the room air, multiply the throw of the selected diffuser at the chosen velocity or flow by .65.

Example: Using Shoemaker DVD-4S Series, 12"×12", operating at 500 fpm neck velocity. The cataloged throws at 150, 100 and 50 fpm are 9', 11' & 14' respectively. Multiplying each by .65 yields throws of 7', 8' & 8.5'.

SOUND LEVEL CORRECTIONS for MULTIPLE GRILLES in ONE ROOM

If several grilles are operating in the same area, the total sound level contribution from them can be obtained as follows. Remember, decibels cannot be added directly.

1. Take the NC level (from the engineering data) for the loudest unit, and add the correction from the chart below for the difference between that and the next loudest unit.
2. For each successive register, grille or diffuser in the room, repeat the procedure.

For a difference of:	0	1	2	3	4	5	6	7	8	9	10
Add this number:	3	3	2	2	2	1	1	1	1	1	0

To Determine Alternate Sizes: Place a straight edge across the width and height scales on dimensions as selected. Place a pointer at the crossing point on the turning line, and rotate the straight edge around this point until it crosses the width and height scale at a desired alternate size. Sizes determined from this chart are nominal duct dimensions.

Selection Of Sizes:

1. Throw should reach approximately 3/4 of distance from outlet to opposite wall.
2. Velocities of air in the air conditioned space are a major factor in the comfort of the occupants in that space. In general these velocities should not exceed 75 FPM in the occupied level in the room.
3. Due to difference of temperature between the entry air and the room air the entry air stream will drop below the level of introduction in the room. Extreme caution and good judgement are required in the selection and location of the supply of air conditioned air so that the air stream will not enter the occupied zone at the critical velocity and cause discomfort due to excessive drafts. If the entry air stream is overthrown and strikes the wall opposite of the grille location downdrafts will occur which will be objectionable to the occupants.

Outlet Selection By Noise Criteria:

The following outlet selection takes into account the room absorption, ceiling height, number of outlets, etc., to match the tabulated outlet NC level with the space NC criteria. A direct comparison of the tabulated outlet NC level (assuming a 10 db room absorption and about a 5 ft. direct field from the single source) to the space NC criteria is used most frequently as a simple selection procedure. The actual outlet NC level obtained in a space depends on the sound power level from the outlet, the number of outlets, the distance from the outlet and the attenuation characteristics of the room. A complete treatment of this is found in the ASHRAE Handbook. However an approximate method follows.

Recommended Delivery Velocities For Various Applications:

The sound caused by an air outlet in operation varies in direct proportion to the velocity of the air passing through it. The air velocity can be controlled by selecting outlets of proper sizes. The following recommended outlet velocities are within safe sound limits for most applications:

APPLICATION RECOMMENDATIONS

Application	Face Velocity (FPM)	NC – Criteria
Broadcasting Studios	500	25
Residences	500–750	25–30
Apartments	500–750	25–30
Churches	500–750	25–30
Hotel Bedrooms	500–750	25–30
Legitimate Theaters	500–1000	20–35
Private Offices (acoustically treated)	500–1000	20–35
Motion Picture Theatres	1000–1250	35–40
Private Offices (not treated)	1000–1250	35–40
General Offices	1250–1500	40–45
Stores (upper floors)	1500	45
Stores (main floors)	1500	45
Industrial Buildings	1500–2000	>45

DIFFUSER TYPE SELECTION

The diffuser, since it is an inexpensive part of an air conditioning or heating system may get a minimum of consideration. This is the device which brings the conditioned air into the presence of the occupants of the room. Their judgement of the whole system may depend on how they consider the supply device works. The return grille has little effect on the conditions within a room as it is a device primarily for covering an opening. The design is important only from an appearance standpoint. The supply diffuser can also be considered a device for covering an opening, in which case it would have thin vanes set to give a minimum resistance to air flow; this gives the maximum effective area for a given diffuser's size. If the vanes of a

diffuser are set to fan the air it causes the supply air to mix quickly with the room air and the portion of the room where high air motion exists is considerably cut down. Setting the vanes to fan the air reduces the effective area. Considering only the effective area of a diffuser can give a distorted view of its effect on the whole system an 18% increase in the effective area by changing the diffuser from a fan type to a straighter flow type only increased the flow to the diffuser by 3.3%. That is, the diffuser loss is such a small percentage of the total branch line loss it is not a controlling factor in the flow to that branch.

REGISTER LOCATION

The measure of how well a given register location or design is performing can be determined by how much stratification (temperature difference between floor and ceiling) exists and how uniform the temperature is on any given level in the room.

THROW AND SPREAD

These terms can be misleading for someone who has not witnessed a smoke test on an air supply device. We tend to liken these terms to what happens when water or ink is spilled on a table. The distance it goes out and the amount it spreads to either side can be definitely measured. Air is a gas and cannot normally be seen, but when smoke is added, its motion can be observed. Within limits when smoke is blown into a room from a supply, in a matter of seconds the room will be so filled with smoke one cannot find a spot to get a breath of clean smokeless air. Throw is the distance from the supply to where the air speed has dropped sufficiently so that the air motion becomes unobjectionable. Air near the end of the throw moves in pulses, the velocity varying from 50, 75, to 100 FPM. At 100 FPM the air motion is beginning to be objectionable to most people. The throw is the distance to the point where the pulses do not go over 75 FPM. It should not, however, be assumed that if the length of the room happens to be more than the noted throw the air will reach the end of the room.

Air from a supply grille, diffuser, or any opening maintains the same velocity for a reasonable distance (several inches) from the opening. The same situation does not hold for the return grille. A return is basically what the aerodynamicist would call a SINK, or a point where air is being sucked in from all directions. Consequently the location of the velocity measuring instrument with respect to the distance away from the grille face can affect the velocity reading more than the actual air flow itself. From a point of an inch or so in front of the grille to a point between the vanes, the reading can vary over 100%. The effect of moving the instrument a given distance away from the grille face will also vary with the size and shape of the opening. The effective area will then vary with how far the velocity measuring device is located from the grille face. To eliminate this problem, the effective area values for the returns in these tables have been selected so that the velocity measuring device was located between the grille vanes. This gives the true velocity reading and will depend only on the suction pressure behind the grille. The effective area values then appear low because of the high velocity reading. The effective area of a return depends primarily on the grille face area and the deflection angle on the vanes. With the vanes at right angle to the face the greatest flow area is obtained, but the grille is less effective in concealing the duct work.

Return Air Sizing Chart: Air brought back to the return air plenum of the furnace must equal the total volume of supply air delivered by the furnace. Careful sizing of return air grilles will assure an adequate air supply to the furnace and prevent air noise at the grille.

Knowing the total CFM delivered by a furnace, you can determine the total free area needed to service the system from the graph below.

Example: The furnace in a small home delivers (and requires) 1000 CFM. Trace the 1000 CFM line in the graph below to the point where it intersects the velocity lines. Now pick off the free areas required to handle 1000 CFM at these velocities from the vertical column on the left.

1000 CFM at 300 fpm requires 480 sq. in.
1000 CFM at 400 fpm requires 360 sq. in.
1000 CFM at 500 fpm requires 288 sq. in.
1000 CFM at 600 fpm requires 240 sq. in.
1000 CFM at 700 fpm requires 206 sq. in.
1000 CFM at 800 fpm requires 180 sq. in.

When a practical velocity value has been established select a grille or grilles with free area equal to or exceeding the free area required for that velocity.

GLOSSARY OF TERMS

REGISTER

A combination grille and damper device for controlling the quantity of airflow

GRILLE

A louvered or perforated face covering an opening

DIFFUSER

An outlet designed to distribute air in varying directions and planes

SLOT

A long, narrow air outlet, generally for which the aspect ratio is greater than 10:1

DROP

The maximum distance, in ft., that the vertical isovel of a horizontally projected air stream drops between the outlet and the end of the throw

RISE

The maximum distance, in ft., that the vertical isovel of a horizontally projected air stream rises between the outlet and the end of the throw

THROW

The distance, in ft., from the center of the outlet perpendicular to the point of terminal velocity. Throws noted in the tables are the distances from the device to where the air stream velocity has dropped to not under 150/100/50 FPM

COANDA EFFECT

A negative or low pressure area is created between the moving air mass and the ceiling at or near the supply air outlet. The low pressure area causes the moving air mass to cling to and flow close to the ceiling surface and increases the flow.

DUCT/NECK SIZE

Nominal Size of the duct opening

CORE AREA

The area of a register or grille pertaining to its frame or border, whichever is less

FREE AREA

The total minimum area, in ft², of the openings in an air outlet or inlet through which air is able to pass.

CORE EFFECTIVE AREA

The area that is utilized by the air passing thru the diffuser or register. This area will always be less than the free area, because the air never fully utilizes the whole free area.

CFM

The volume of standard air per unit of time that moves past a given plane, expressed in cubic feet per minute.

VELOCITY PRESSURE (PV)

The forward moving force of air within a duct, measured in inches of water column

STATIC PRESSURE (PS)

The outward force of air within a duct, measured in inches of water column

TOTAL PRESSURE (PT)

The sum of the velocity and static pressures, expressed in inches of water column and can be obtained by use of a pitot tube.

$$Pt = Pv + Ps$$

NOISE CRITERIA (NC)

A sound rating in pressure level given in decibels based on established criteria and specific room acoustic absorption values. Catalog NC ratings are based on 10db room attenuation, 10–12 watts with a 8db attenuation in all octave bands.

NC SCALE:

Less than NC25: Extremely quiet

NC25–30: Quiet offices

NC30–35: Conference rooms, normal voice
10–30ft.

NC35–40: Conference rooms, normal voice
6–12ft.

NC45: Conference rooms, normal voice 3–6ft.

NECK VELOCITY

The velocity, in FPM, of air traveling through the duct connected to the air outlet or inlet. Neck velocity is measured by dividing airflow rate (CFM) by core effective area.

DAMPER OR VALVE



A device used to control the volume of air passing through a duct by varying the cross sectional area.

POWDER COAT PAINT

Shoemaker uses a baked-on textured polyester powder coat paint with a rust-resistant prohibitive pre-coat. Powder coat paint is an extremely durable finish and holds up well to the stress of shipping, installation, general wear and aging. This finish resists the peeling, cracking, chipping, fading and other problems associated with e-dip and other painting methods. Powder coat paint also serves as an excellent primer when final paint color is applied in the field.

Shoemaker's standard paint colors are  and .

 Designer color finishes (additional charge) include: , , , , ,  and . Paint samples available upon request.

  (additional charge) closely replicates a cleaned aluminum finish with the added benefits of powder coat paint.

Additional paint colors available by quote, extended leadtimes and additional charges apply. Contact customer service.

SATIN ANODIZED

Satin anodized aluminum extrusions best described as a polished aluminum look. Factory cleaned. Available on products where noted.

Additional anodizing options available by quote, extended leadtimes and additional charges apply. Contact customer service.

MILL FINISH

Raw (no finish), factory cleaned.

GALVANIZED FINISH

Steel with protective zinc coating. Factory cleaned. Closely matches finish of galvanized spiral pipe.

STAINLESS STEEL

Stainless steel available where noted.

TYPE 304 STAINLESS STEEL: Type 304 stainless steels can meet a wide variety of physical requirements, making them excellent materials for applications including auto molding and trim, wheel covers, kitchen equipment, hose clamps, springs, truck bodies, exhaust manifolds, stainless flatware, storage tanks, pressure vessels and piping.

The 18% chromium, 8% nickel, provides good resistance to moderately acidic or caustic solutions. Type 304 may be considered to perform similarly in most non-severe applications. A notable exception is in the case of welding. Low carbon (304L) is the recommended alloy and provides increased resistance to intergranular corrosion.

TYPE 316 STAINLESS STEEL: Type 316 alloy is a molybdenum bearing stainless steel. It has a greater resistance to chemical attack than the 304 family. Type 316 is durable, easy to fabricate, clean, weld and finish. It has superior corrosion resistance when exposed to many types of chemical corrodents such as sea water, brine solutions, and the like.

The addition of 2% molybdenum makes Type 316 considerably more resistant to corrosion and oxidation than the 304 family of alloys.

INDEX

100 Series Step Down Ceiling Diffuser	100
100-D	100
100-O	100
104P Series Perforated Curved Blade T-Bar Diffuser	36
104P-D	36
104P-O	36
104 Series Stamped Curved Blade T-Bar Diffuser	20
104-D	20
104-O	20
104P	20
105FG Stamped Face T-Bar Filter Grille	58
106FG	58
105PFG Series Perforated Face T-Bar Filter Grille	52
106PFG	52
105P Series Fixed Perforated T-Bar Return Grille	41
105P-D	41
105P-O	41
110 Series Perforated Fiberglass Back T-Bar Diffuser	32
111	32
115T Series Flush Step Down T-Bar Diffuser	25
116T	25
500 Series Perforated Curved Blade Surface Mount Diffuser	96
500CB	96
500MA	96
500MA-O or 500CB-O	96
600P Series Perforated Return Air Grille	97
600P-O	97
600P-SS Series Stainless Steel Perforated Return Air Grille	239
600PTFG Series Perforated Face T-Bar Filter Grille with Frame	53
601PTFG	53
600PT Series Perforated Return Air T-Bar with Frame	42
600PT-O	42
601PT	42
600 Series Lattice Return Air Grille	98
600-O	98
645	98
646	98
600-SS Series Stainless Steel Eggcrate Return Air Grille	240
600TFG Series Aluminum Lattice T-Bar Filter Grille	54
601TFG	54
645TFG	54
600T Series Aluminum Lattice Return Air Grille T-Bar with Frame	46
600T-O	46
601T	46
645F-T	46
645T	46
620FG Lattice Filter Grille	112
600FG1/600FG2	112
620FG1	112
620FG2	112
620FG4	112
620PFG1/620PFG2/620PFG4	112
645FG1/645FG2	112
646FG1/646FG2	112
700-600P Series Perforated Return Air Grille T-Bar Panel	44
700-600P-O	44

700-600 Series Aluminum Lattice Return Air Grille in T-Bar Panel48
700-600-048
700-64548
700-935 Fixed 45° Blade Return Air Grille in T-Bar Panel51
700-935-051
700CB Series Adjustable Curved Blade Diffuser in T-Bar Panel17
700CB-017
700DVD Series Directional Volume Diffuser in T-Bar Panel22
700DVD-ADJ22
700DVD-022
700MA Series Modular Core Diffuser in T-Bar Panel14
700MA-0 / 700MCB-014
700MCB14
700 Series T-Bar Panel Only59
700-SS Series Stainless Steel T-Bar Panel Only249
780 Series Perforated T-Bar with Adjustable Pattern Controllers34
78134
825CB-SS Series Stainless Steel Perforated Adjustable Curved Blade T-Bar Diffuser245
825 Series Perforated Curved Blade T-Bar Diffuser38
825CB38
825MA38
830 Series Hinged Perforated T-Bar Return43
830-SS Series Stainless Steel Perforated Adjustable Curved Blade T-Bar Diffuser245
901/902 and 931/932 Series Single Deflection Adjustable Blade Diffusers80
903/904 and 933/934 Series Double Deflection Adjustable Blade Diffusers82
905-908 and 935-938 Series Fixed Blade Return Air Grilles84
905FG Fixed 45° Airfoil Blade Filter Grille114
901FG/902FG114
905FG1114
905FG2114
905FG4114
906FG1/906FG2/906FG4114
907FG/908FG114
905TFG Series Fixed 45° Airfoil Blade T-Bar Filter Grille56
905TFG-456
915/916 Series Fixed Bar Blade Grille88
915-0 / 916-088
915FG Fixed Bar Blade Filter Grille117
915FG1117
915FG2117
915FG4117
916FG1/916FG2/916FG4117
915-SS Series Stainless Steel 45° Fixed Louvered Blade Return Air Grille238
916-SS238
915TFG Series Fixed 45° Bar Blade T-Bar Filter Grille57
915T Series Fixed 45° Bar Blade T-Bar Return Air Grille50
915T-050
931-SS Series Stainless Steel Single Deflection Diffuser233
932-SS233
933-SS Series Stainless Steel Double Deflection Diffuser234
934-SS234
935FG Fixed 45° Steel Blade Filter Grille115
935FG1115
935FG2115
935FG4115
936FG1/936FG2/936FG4115
935FG-SS Series Stainless Steel Fixed 45° Airfoil Blade Hinged 1" Filter Grille241
935-SS Series Stainless Steel 45° Fixed Airfoil Blade Return Air Grille235

936-SS	235
937-SS	235
938-SS	235
935TFG Series Fixed 45° Steel Blade T-Bar Filter Grille	55
935f-TFG	55
935TFG-4	55
935T Series Fixed 45° Steel Blade T-Bar Return Air Grille	49
905T	49
935T-0	49
945 Series Adjustable Blade 3 or 4-way Diffuser	94
945-0	94
950 Series Adjustable Blade Diffuser	92
950-0	92
951	92
1000 Series Sill Grilles	90
1000R-DW / 1000S-DW	90
1000R-0 / 1000S-0	90
1201 Series Aluminum Adjustable Round Diffuser	119
1202 Series Aluminum Round Spot Diffuser	120
1202R	120
1205	120
1203 Series Aluminum Turbo Nozzle Diffuser	121
1204	121
1301-1308 Series Architectural Design Stamped Pattern Grilles	122
1401 Series Bar Type Security Grille	202
1402 Series Face Plate / Screen / Backer Plate Security Grille	203
1404 Series Wire Screen Face Security Return	204
1405 Series Square Hole Lattice Face Security Grille	205
1406 Series Security Grille Perforated Face	206
1407 Series Rectangular Hole Lattice Face Security Grille	207
1408 Series Lattice Face Security Diffuser	208
1409 Series Risk Resistant Security Grille Perforated Face	209
1410 Series Risk Resistant Louvered Face Security Diffuser and Sleeve	210
1560 Series Gym Grade Bar Register with 0° Deflection	107
1525	107
1610 Series Gym Grade Bar Grille with 0° Deflection	110
1625	110
2502 Series Thin-line 1 1/2 Hour Rated Fire Damper	172
2501	172
2534 Series Thin-line Out-of-Airstream 1 1/2 Hour Fire Damper	173
2533	173
2550 Series Round Thin-line Out-of-Airstream 1 1/2 Hour Rated Fire Damper	174
2549	174
2561 Series Thin-line 3 Hour Rated Fire Damper	175
2563	175
2565	175
2602 Series 1 1/2 Hour Rated Fire Damper	177
2601	177
2634 Series Out-of-Airstream 1 1/2 Hour Rated Fire Damper	178
2633	178
2650 Series Round Out-of-Airstream 1 1/2 Hour Rated Fire Damper	179
2649	179
2652 Series True Round 1 1/2 Hour Rated Fire Damper	180
MAR	180
2661 Series 3 Hour Rated Fire Damper	181
2663	181
2665	181
2700CBA Series 1 Hour Rated Ceiling Radiation Damper with Register Box Assembly	186

2701 Series 3 Hour Rated Ceiling Radiation Butterfly Damper	184
2702	184
2720 Series 3 Hour Rated Ceiling Radiation Curtain-Type Damper	188
2750CBA Series 1 Hour Rated Round Ceiling Radiation Damper with Register Box Assembly	187
2750 Series Round 3 Hour Rated Ceiling Radiation Butterfly Damper	185
2751	185
2800 Series 1 1/2 Hour Dynamic Fire Damper	195
3000-OBDD Series Opposed Blade Air Control Damper	145
3000AF-OBDD	145
3000-OBDDL	145
3000P-R Series Round Air Control Damper	146
3000P-RLL	146
3000 P Series Parallel Blade Air Control Damper	144
3000AF-P	144
3000 PLL	144
3100 Series Face and By-Pass Dampers	147
3101	147
3102	147
3103	147
3101-OBDD, 3102-OBDD, 3103-OBDD	147
3101-LL, 3102-LL, 3103-LL	147
3101-P, 3102-P, 3103-P	147
3510 Series Vertical Mount Pressure Relief Damper	148
3520	148
3530	148
3550 Series Vertical Mount Backdraft Damper	149
3560	149
3570	149
3580	149
4000 Series Aluminum Transfer Door Grille	79
4100	79
4100-SS Series Stainless Steel Louvered Door Grille with Auxiliary Frame	237
4500 Series Stationary 4" Outside Air Louver	152
4525 Series Storm Resistant Stationary 4" Drainable Outside Air Louver	154
4550 Series Stationary 2" Outside Air Louver	156
4600 Series Adjustable 4" Outside Air Louver	158
4700 Series Stationary 4" Outside Air Louver Radius and Special Shapes	159
4750	159
4800 Series Extruded Aluminum Brick Vent	160
4850	160
4901 Series Round Aluminum Vent Louver	161
4902	161
5160 Series Flat Radial Diffuser with 90° Air Flow Pattern	223
5180 Series Hinged Radial Diffuser with 90° Air Flow	225
5300 Series Laminar Flow Diffuser Panel	216
5350 Series Medium Capacity Laminar Flow Diffuser Panel	218
5375 Series High Capacity Laminar Flow Diffuser Panel	220
5500 Series Hemispherical Diffuser	227
5600 Series Sterile Room Perimeter Slot Diffuser	229
5700 Series Fan Powered Laminar Flow Diffuser with HEPA Filter	222
6000 Series Insulated Access Door	167
6001	167
6500	167
6501	167
6600 Series Insulated Access Door	168
6700 Series Insulated Access Door	167
6800 Series Fire Rated Wall Access Door	190
6900 Series Fire Rated Ceiling Access Door	191

Accessories	
Commercial	123
Fire Smoke	196
Security Grilles	212
T-Bar	60
AD Series Access Door	167
FG/AD	167
AL Series Aluminum Lattice Return T-Bar	45
BD Series Bowtie Damper	59
CB Series Adjustable Aluminum Curved Blade Diffuser	64
CB-T Series Adjustable Curved Blade T-Bar Diffuser	19
CB-T-0	19
CFSD-222-2 Series 1 Hour Corridor Fire & Smoke Damper	193
D4120 Innovair Duct Smoke Detector	196
Damper Louver Combinations	162
DVD Series Square and Rectangular Directional Diffuser	102
DVD-CM	102
DVD-DCF	102
DVD-0 / DVD-0-DCF	102
DVD-SS Series Stainless Steel Surface Mount Louvered Ceiling Diffuser	242
DVD-T Series Directional Volume Diffuser T-Bar	24
DVDT-0	24
FR Series T-Bar Ceiling Air Diffusers and Returns with UL Fire Resistance Classification	189
FSD-111-2 Series 1 1/2 Hour Fire & Smoke Damper	192
HF Series HEPA Filter	231
UF	231
HL Series Architectural Plaque T-Bar Diffuser	30
AA-HL	30
HL-1×1	30
HL-ADJ	30
SM-HL	30
HL-SS Series Stainless Steel Architectural T-Bar Plaque Diffuser	244
HVD Series 4 Cone T-Bar Diffuser	26
AA-HVD	26
FTD	26
HVD-1×1	26
HVD-ADJ	26
HVD-SS Series Stainless Steel Adjustable 4-Cone T-Bar Diffuser	243
HVL Series 3 Cone T-Bar Diffuser	28
AA-HVL	28
HVL-1×1	28
HVL-ADJ	28
Linear Air Bars	140
Linear Bar Diffusers and Grilles	129
Linear-SS Series Stainless Steel Linear Bar Grille	246
Linear Slot Diffusers	135
LSD-SS Series Stainless Steel Linear Slot Diffuser	247
MA Series Modular Core Diffuser	68
MA-CM	68
MA-DCF	68
MA-0 / MA-0-DCF	68
MCB	68
MA-SS Series Stainless Steel Surface Mount Fixed Pattern Ceiling Diffuser	232
MA-T Series Modular Core Diffuser T-Bar	16
MA-T-1×1	16
MA-T-0	16
PT Series Perforated T-Bar	40
600PT	40

RDA Series Adjustable Round Ceiling Diffuser118
RDA-OBR118
RS Series Radius Spiral Pipe Diffuser76
RS34-FS, RS52-FS76
RS34-0, RS52-076
RS34-SC, RS52-SC76
RS-SS Series Stainless Steel Radius Spiral Diffuser248
SD-SS248
SD Series Transition Box Spiral Pipe Diffuser73
SD34-FS, SD52-FS73
SD34-0, SD52-073
SD34-SC, SD52-SC73
SR Series Combination Curved Blade Supply and Perforated Return105
USR Series Universal Spiral Diffuser70
A-USR34, A-USR5270
USR34-0, USR52-070
USR34-FS, USR52-FS70
USR34-SC, USR52-SC70



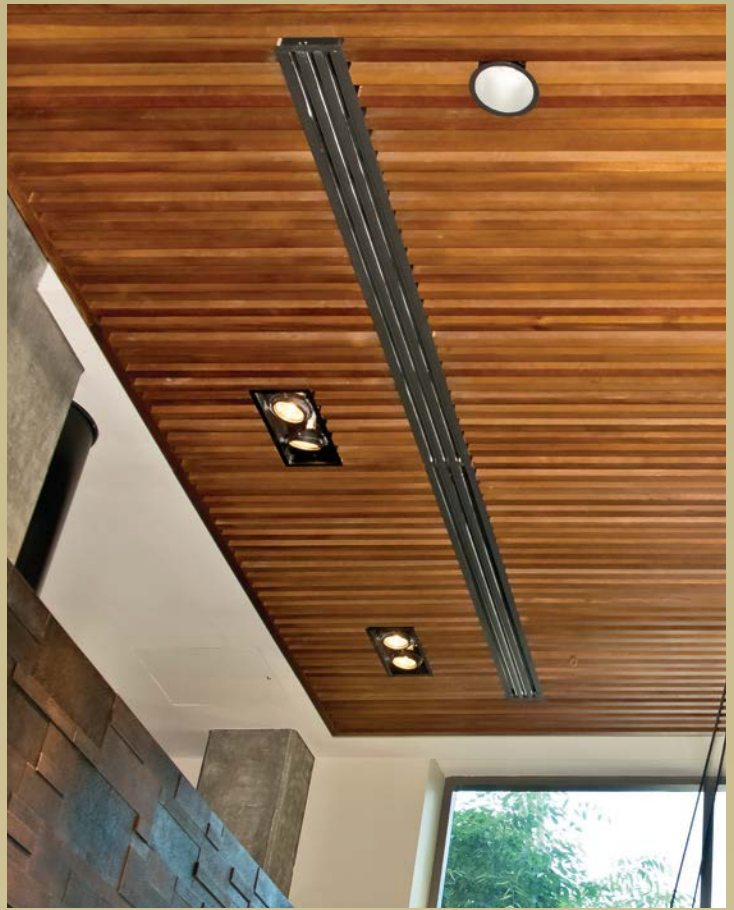

Shoemaker Manufacturing

104 Montgomery Avenue

Cle Elum, WA 98922

P: (866) 940-0696 or (509) 674-4414 F: (509) 674-4420

www.shoemakermfg.com

sm@shoemakermfg.com