

MULTIPLE SECTION DAMPER INSTALLATION INSTRUCTIONS

VERTICAL MOUNT 1-1/2 HOUR RATING

(For use in 2 hour or less rated partitions)

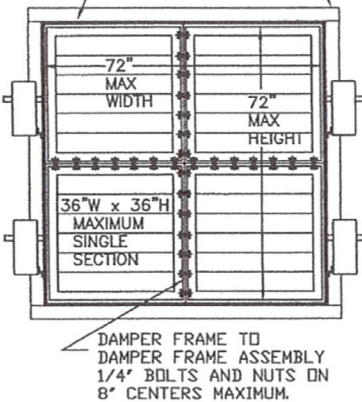
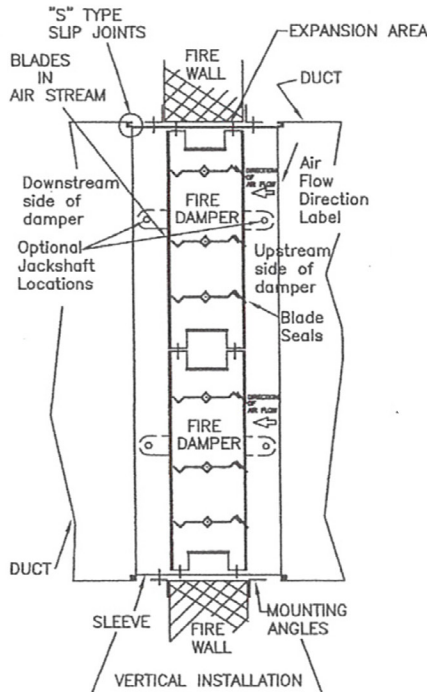

Damper shall be fastened to sleeve with #10 or #8 x 3/4" sheet metal screws on 6" centers (max) no further than 2" from either end.

See Notes 2 and 3 regarding duct connections.

Angles shall be a minimum of 1-1/2" x 1-1/2" x 1/16" and fastened to the sleeve and damper only.

Must be fastened on all (4) sides with 1/4" bolts, 1/2" long welds or no.10 or no.8 sheet metal screws on 8" maximum centers. (See note #4 for expansion clearance and overlap).

Angles shall not be fastened to each other at the corners or fastened to the fire wall.

Angles may be reversed when diffusers or grilles require flush mounting.

Installation per NFPA90A, UL555 and SMACNA Fire Smoke and Radiation Installation Guide.

FASTENERS MUST BE PLACED WHERE THEY DO NOT INTERFERE WITH DAMPER OPERATION.

NOTES:

- Sleeves shall be 15 gauge or heavier than the duct to which it is attached. Gauges shall conform to SMACNA or ASHRAE standards.
- When the following sleeve connections are used, the minimum gauge of the sleeve shall be 14 gauge.
 - Angle reinforced standing seam
 - Angle reinforced pocket lock
 - Companion angles
 - Metal fasteners approximately 16" on centers
- The following breakaway sleeve connections may be used on all systems:
 - Plain "S" slip
 - Hemmed "S" slip
 - Bar slip
 - Standing "S" slip
 - Reinforced bar slip
 - Angle slip
 - Inside slip joint
 - Double "S" slip
- Clearance for expansion of 1/8" per foot of sleeve dimensions is required. Angles should overlap masonry a minimum of 1" around the entire opening.
- For multiple section damper assemblies larger than 72" x 72", refer to the mullion installation instruction sheet for fire damper.
- Maximum sleeve extension from the wall or floor opening is 6" on the damper side without actuator.
 Maximum sleeve extension from the wall or floor opening is 16" on the damper side with actuator.
- Dampers may be installed in wall or partition (masonry, gypsum wallboard) or concrete floor.
- The connection ducts shall not be continuous, but shall terminate at the sleeve or frame.
- Dampers are supplied with factory mounted actuators designed to close automatically upon loss of power.
- The jackshaft side of the damper may be installed either "upstream" or "downstream".
- A continuous bead of Dow Corning RTV-732, Dow Corning 999A, GE-1200 Silicone Rubber Sealant (or approved equal) shall be applied between the damper and the sleeve for its entire profile on one side of the installation as a minimum.
- Installed damper units require operational checks upon completion to ensure proper functioning.
- An access door is a NFPA requirement for damper inspection and testing.
- For use in static and dynamic systems up to the maximum rated temperature, velocity and water gauge.
- Electric actuator connections shall conform to the National Electric code.
- Pneumatic actuators require metallic airline connections, and a minimum of 20PSI supply air (not to exceed 30PSI).
- CAUTION: THE HEAVY DAMPER CLOSURE SPRING IS UNDER LOAD.**

MAXIMUM MULTIPLE SECTION

TYPE INSTALLATION	SINGLE UNITS IN INCHES	
	Width	Height
	72	72

MAXIMUM SINGLE DAMPER SECTIONS
 MODELS: FSD-111, SD-333, FD-111.
 36" WIDE x 36" HIGH
 30" WIDE x 48" HIGH

EACH SINGLE SECTION DAMPER SHALL BE SUPPLIED WITH AN INDEPENDANT MOTOR OPERATOR.

FUSIBLE LINKS

Temperature rating is not to exceed 250° F
 165° F is standard.
 Located in pin grooves.

