

**Standard Features:**

- Double deflection aluminum wall or ceiling register
- Heavy gauge aluminum frame
- Individually adjustable extruded aluminum airfoil blades
- Provides wide dispersion patterns to long throw narrow air streams
- Hidden mounting mechanism
- Gloss white

**Options:**

MRI Compatible

**Finishes:**

STANDARD COLOR

Gloss White

OPTIONAL COLOR

Mill Finish

**1201 Series Dimensions**

SIZE	A	B	C	D	E	F	G
6"	7 5/8"	5 13/16"	1 7/32"	4 9/32"	15/32"	5 1/2"	21/32"
8"	10"	7 25/32"	1 13/32"	4 9/32"	15/32"	5 1/2"	23/32"
10"	12 5/8"	9 3/4"	1 25/32"	4 13/32"	19/32"	5 1/2"	29/32"
12"	14 19/32"	11 23/32"	1 25/32"	4 13/32"	19/32"	5 1/2"	15/16"
14"	16 9/16"	13 11/16"	1 25/32"	4 13/32"	19/32"	5 1/2"	15/16"
16"	18 17/32"	15 21/32"	1 25/32"	4 13/32"	19/32"	5 1/2"	31/32"
20"	23 5/8"	19 23/32"	2 3/8"	4 31/32"	29/32"	6 11/16"	31/32"
24"	27 9/16"	23 11/16"	2 3/8"	4 31/32"	29/32"	6 11/16"	31/32"

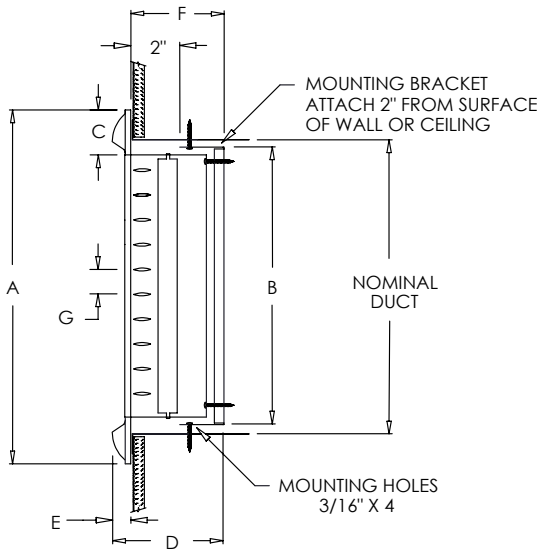

1201

**Additional Information:**

**Submittal Notes**

Project / Location:	
Engineer:	
Architect:	
Contractor:	