

Damper Louver Submittal

Parallel Blade Air Control Damper

MODEL: 3000 P Series

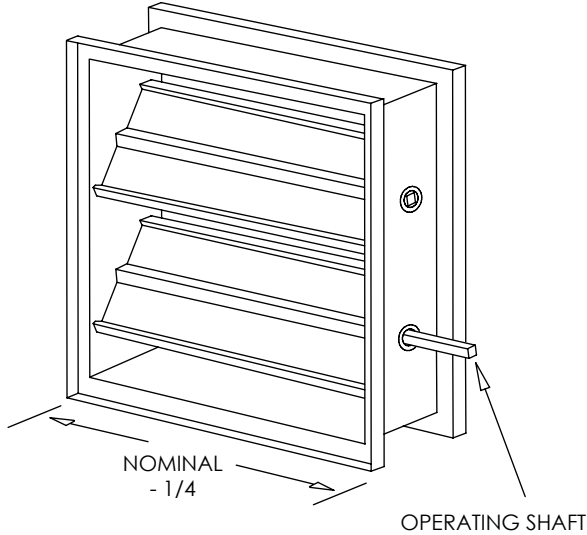

NOMINAL
- 1/4

OPERATING SHAFT

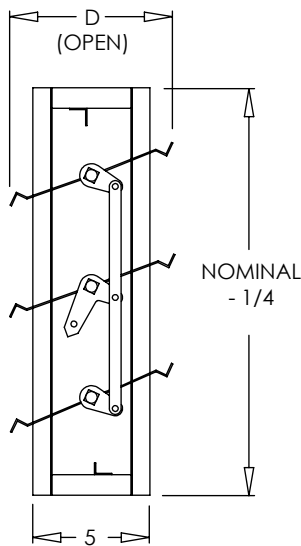

3000-P

Standard Features:

- Parallel blade operation for precise volume control
- 16 gauge galvanized channel frame
- Galvanized blades are vee stiffened for extra strength and stability
- Blades pivot on high temperature nylon bushings
- 1/2" square zinc plated steel pivot pins
- 1/2" square zinc plated steel adjustable operating shaft, extends up to 4" beyond the air control frame
- Single blades on dampers with a height of 10" or less
- Blades run parallel to first dimension given
- Blades must be operated on horizontal plane
- Minimum size 8"x8"
- Maximum one piece size 48"x48"
- Galvanized Finish

Options:

Low Leak Package: features stainless steel jamb seals, blade to blade neoprene seals, and 3% maximum leakage with a pressure differential 3" W.C. (3000-PLL)

Air control damper with aluminum airfoil blades. The airfoil blade design provides excellent pressure drop performance over standard blade design. (3000AF-P)

Double blades on dampers with a height of 8" or 10" (i.e. 3000-P-8x8 DB.) 12 gauge galvanneal construction

Extended square operating shaft (extending 7 1/2" beyond the air control frame)

Round operating shaft (1/2" diameter)

Spring opening damper

Spring closing damper

Oil impregnated bronze bearings

Outside mounting flange

Direct mount damper motor (field installed.) Mounts on operating shaft.

Standard operating shaft position is bottom right, back side of damper blades when viewed from the face of the product.

Fractional and exact O.D. dimensions

Finishes:

STANDARD COLORS

Galvanized

3000 OBD		3000 OBD		3000 OBD	
HEIGHT	OPEN DEPTH (D)	HEIGHT	OPEN DEPTH (D)	HEIGHT	OPEN DEPTH (D)
6"	5"	18"	8"	34"	7"
8"	7 1/8"	20"	6 1/2"	36"	8"
8" DB.	5 1/2"	22"	7"	38"	6 1/2"
10"	9 1/8"	24"	8"	40"	7"
10" DB.	5 1/2"	26"	6 1/2"	42"	8"
12"	5 3/4"	28"	7"	44"	6 1/2"
14"	6"	30"	8"	46"	7"
16"	7"	32"	6 1/2"	48"	8"

Note Add 1 3/8" to Open Depth (D) for Low Leak Package

Additional Information:

Submittal Notes

Project / Location:

Engineer:

Architect:

Contractor: