

Damper Louver Submittal

Combination Stationary 2" Outside Air Louver with Parallel Blade Air Control Damper

MODEL: 4550-3000P Series

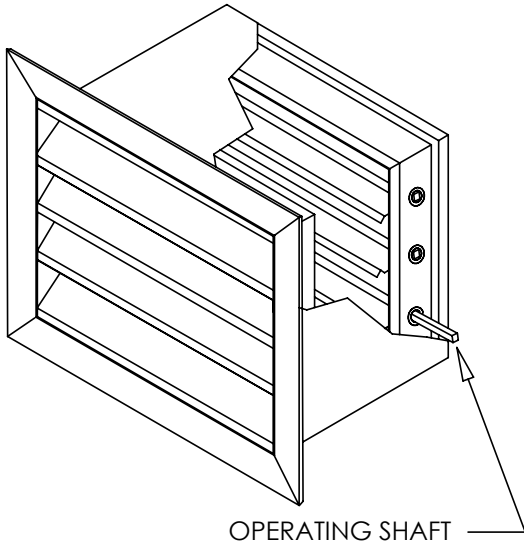

OPERATING SHAFT

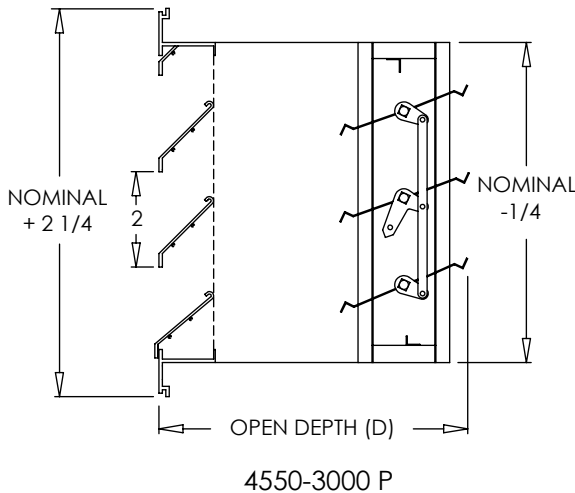

Standard Features:

- Dampers and louvers can be combined with a 20 gauge steel sleeve to create an environment to regulate airflow in or out of a louver with an operable blade damper.
- Minimum size 6"x6"
- Maximum one piece size 48"x48"

4550:

- Extruded aluminum construction
- Storm bend on louvers to minimize water from entering behind louver
- Standard flange frame
- 2" depth
- Bird screen (1/2" x 1/2")
- Louvers set at 45° on 2" centers
- Blades run parallel to first dimension given
- Driftwood Tan

3000P:

- Parallel blade operation for precise volume control
- 16 gauge galvanized channel frame
- Galvanized blades are vee stiffened for extra strength and stability
- Blades pivot on high temperature nylon bushings
- 1/2" square zinc plated steel pivot pins
- 1/2" square zinc plated steel adjustable operating shaft, extends up to 4" beyond the air control frame
- Single blades on dampers with a height of 10" or less
- Blades run parallel to first dimension given
- Blades must be operated on horizontal plane
- Galvanized finish

Options:

Low Leak Package: features stainless steel jamb seals, blade to blade neoprene seals, and 3% maximum leakage with a pressure differential 3" W.C. (4550-3000 PLL)

Flush mount channel frame (4550-CF-3000 P)

Offset flange frame, must specify flange placement (4550-OF-3000 P)

Insect Screen (4550-IS-3000 P)

Direct mount damper motor (field installed.) Mounts on operating shaft.

Standard operating shaft position is bottom right, back side of damper blades when viewed from the face of the product (see product drawing for standard operating shaft position).

Double blades on dampers with a height of 8" or 10" (i.e. 4550-3000 P-8x8 DB.)

Fractional, exact I.D. and O.D. dimensions

Finishes (louver only):

STANDARD COLORS

- Soft White
- Driftwood Tan
- Mill Finish

DESIGNER COLORS

- Black
- Bronze
- Storm Gray
- Cement Gray

- Aluminum Paint
- Coffee Tan
- Warm White
- Glossy White

Additional Information:

Submittal Notes

Project / Location:	
Engineer:	
Architect:	
Contractor:	

Damper Louver Submittal

Combination Stationary 2" Outside Air Louver with Parallel Blade Air Control Damper

MODEL: 4550-3000P Series

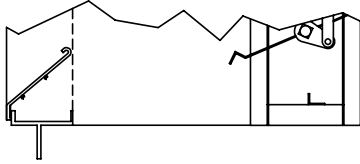

Offset Flange Frame
4550-3000 P OF

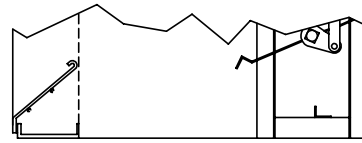

Flush Mount Channel Frame
4550-3000 P CF

4550-3000 P	
HEIGHT	OPEN DEPTH (D)
6"	15"
8"	16 1/8"
8" DB.	15"
10"	17 1/8"
10" DB.	15 1/2"
12"	15 3/4"
14"	15 3/4"
16"	16 1/4"

4550-3000 P	
HEIGHT	OPEN DEPTH (D)
18"	17 1/4"
20"	15 3/4"
22"	16 1/4"
24"	17 1/4"
26"	15 3/4"
28"	16 1/4"
30"	17 1/4"
32"	15 3/4"

4550-3000 P	
HEIGHT	OPEN DEPTH (D)
34"	16 1/4"
36"	17 1/4"
38"	15 3/4"
40"	16 1/4"
42"	17 1/4"
44"	15 3/4"
46"	16 1/4"
48"	17 1/4"

Note: Add 3/4" to Open Depth (D) for Low Leak Package

Additional Information:

Submittal Notes

Project / Location:	
Engineer:	
Architect:	
Contractor:	